

TABLE OF CONTENTS

Enclosure 1

Part I: Drill

<u>CHAPTER</u>	<u>TITLE</u>
1.	Introduction to Drill
2.	Individual Instructions without Arms
3.	Manual of Arms with the Service Rifle
4.	Manual of Arms with the Handgun
5.	Sword Manual
6.	Guidon Manual
7.	National and Organizational Flags
8.	Squad Drill
9.	Platoon Drill
10.	Company Drill
11.	Battalion Drill
12.	Regimental Drill

Enclosure 2

Part II: Ceremonies

<u>CHAPTER</u>	<u>TITLE</u>
1.	Inspections
2.	Organizational and Parade Staff
3.	General Information
4.	Reviews
5.	Parades
6.	Presentation of Decorations and Individual Retirement
7.	Change of Command Ceremony
8.	Relief and Appointment of the Sergeant Major
9.	Activation and Deactivation Ceremony
10.	Honors
11.	Marine Corps Birthday Cake Cutting Ceremony
12.	Mess Night
13.	Funerals and Memorial Services
14.	Loading and Ceremonial Firing of the Service Rifle

Enclosure 3

Appendices

<u>APPENDIX</u>	<u>TITLE</u>
A.	Manual of Arms with the M1 Service Rifle
B.	Rifle Manual for the M14 Service Rifle
C.	Ceremonial Property
D.	History, Customs and Courtesies, and Traditions of the Mess Night

Chapter 1

Inspections

TABLE OF CONTENTS

<u>IDENTIFICATION</u>	<u>TITLE</u>	<u>PAGE</u>
1.	General.....	1-2
2.	Company Formations.....	1-2
3.	Inspection of Personal Field Equipment in Ranks...	1-4
4.	Inspecting of Officer Other than Company Commander	1-5
5.	Battalion Inspections.....	1-5
6.	Regimental Inspection.....	1-6
7.	Inspection of Quarters or Camp.....	1-6
Figure 1-1	Company Formed for Inspection, Company in Line....	1-7
Figure 1-2	Company Formed for Inspection, Company Column of Platoons in Line.....	1-8
Figure 1-3	Inspection of Personal Field Equipment in Ranks...	1-9
Figure 1-3a	Inspection of Personal Field Equipment in Ranks Platoon Spacing.....	1-10

Chapter 1

Inspections

1. General. The company is the basic unit for inspection. Battalion, regimental, and higher commanders or inspecting officers inspect each company in its own area, or have it march to a specified place at a designated time for inspection. Under special conditions, an entire battalion or regiment may be inspected in one large formation.

2. Company Formations

a. General. The company forms in line or in column of platoons in line as prescribed in enclosure 1, chapter 10. If transportation is included, it forms 12 paces in rear of the troops. Drivers remain with their vehicles. (See figure 1-1.)

b. Procedure

(1) When ready to inspect, the company commander commands "**PREPARE FOR INSPECTION.**" At this command, the platoon commanders open ranks by platoons. The right platoon executes the initial movement. The second platoon, as described in enclosure 1, chapter 9, paragraph 17, opens ranks when the front rank of the first platoon has been aligned. The third and subsequent platoons do not begin to open ranks until the front squad of the platoon to its right has been aligned. All platoon commanders align their squads on the corresponding squad of the platoon to their right. (See figure 1-1.) When the formation is a column of platoons in line, platoon commanders open ranks successively from front to rear without awaiting the alignment of the platoon to their front. They cause their units to cover the corresponding files to their front. (See figure 1-2.) In opening ranks and aligning their platoons, platoon commanders comply with the procedures prescribed for platoon drill. After verifying the alignment of the rear rank, each platoon commander faces to the right as in marching, moves three paces beyond the front rank, faces the left, and commands "**Ready, FRONT**" and "**COVER.**" After giving the command "**COVER,**" each platoon commander takes one step forward and faces to the front, thereby being in a position three paces in front of the right file of the front rank of their respective platoon. It is at this post that the platoon commander receives the inspecting officer.

(2) When all ranks have been opened, the company commander commands "**AT EASE.**" He/she then inspects the company. During the inspection, officers, staff noncommissioned officers, and guidon bearers, not in ranks, come to attention at order arms as the company commander approaches. After being inspected, they resume at ease. The company commander may direct the first sergeant to accompany him/her for the purpose of taking notes. The inspection begins at the head of the column or the right of the line. The company commander inspects the arms, equipment, dress, and appearance of the personnel. As he/she approaches each platoon, its commander brings his/her unit to attention and salutes. After being personally inspected, the platoon commander returns sword (if so armed) and places himself/herself on the right of the company commander. He/she precedes the company commander during the entire inspection, down the front and rear of each squad. The company commander may direct that squads having been or not yet inspected be given at ease while he/she inspects others. In this case, the platoon commander complies and brings them to attention for inspection at the proper time.

(3) The inspection is made from right to left in the front and from left to right in the rear of each rank. After inspecting the platoon commander, the company commander moves around the platoon commander's left to a position in front of the right flank Marine in the first rank. He/she moves from Marine to Marine by stepping off to the right as in marching, taking one and one half steps, halting, and executing a left face. The platoon commander must move in the same manner so as not to be in the company commander's way.

(4) Each Marine executes the movements to inspection arms for his/her weapon immediately after the company commander has completed the left face movement and is facing him/her.

(5) The company commander takes all individual weapons from the individual being inspected. He/she takes the rifle by grasping the handguard with his/her right hand. The Marine whose rifle is being inspected immediately drops his/her hands to the sides. After inspecting the weapon, the company commander hands it back with his/her right hand in the same position. The Marine smartly takes his/her weapon by grasping the center of the handguard just forward of the slip-ring with his/her left hand, closes the bolt, pulls the trigger, and returns the weapon to order arms as soon as he/she receives it. The company commander takes and returns other weapons in the most convenient manner. A detailed inspection will include bayonets and other equipment carried.

(6) Bayonets will be inspected when the company commander is in the rear of the rank. He/she will take and replace them without assistance from the Marine being inspected. The Marine will merely raise his/her left arm when the company commander takes and replaces the bayonet.

(7) Upon completion of the inspection of his/her platoon, the platoon commander, having led the company commander down the rear of the last squad, executes column left and halts when three paces beyond the right flank member of the first rank. He/she faces left, calls the entire platoon to attention, and then resumes his/her post, (see paragraph 2.b.(1) of this chapter) the company commander passes to his/her right, faces to the left as in marching, halts, and executes a left face. He/she then gives the platoon commander any instructions necessary. The platoon and company commanders exchange salutes and the latter proceeds to the next platoon.

(8) Upon completion of the inspection of each platoon, its commander faces to the left and orders "**Close Ranks, MARCH.**" At the command "**MARCH,**" the platoon commander moves by the most direct route and takes his/her post six paces in front of and centered on his/her platoon.

(9) The company commander may direct the platoon commanders to make the detailed inspection by ordering "**Platoon Commanders, INSPECT YOUR PLATOONS.**" In this case, each platoon commander complies. They may direct their platoon sergeants to accompany them for the purpose of taking notes. The company commander will normally spot check individuals while platoon commanders are inspecting their platoons. In this case, Marines at ease will automatically come to attention upon the company commander's approach, and to inspection arms if the company commander stops in front of them, regardless of whether they have been previously inspected.

3. Inspection of Personal Field Equipment in Ranks

a. The company forms in company column of platoons in line at open ranks, for a preliminary rifle inspection. After the inspection of the first platoon, the company commander directs the platoon commander to prepare for inspection of equipment. Upon the company commander's departure to inspect the arms of the next platoon, the platoon commander orders, "**First Squad, two Paces Forward, MARCH;**" "**Second Squad, one Pace Forward, MARCH;**" and "**Fourth Squad, two Paces Backward, MARCH.**" (See figures 1-3 and 1-4.) The platoon commander then causes the platoon to take interval to the left, after which he/she commands "**UNSLING EQUIPMENT.**" Upon the completion of this, the platoon commander orders "**DISPLAY EQUIPMENT.**"

b. At the command "**UNSLING EQUIPMENT,**" each Marine draws their bayonet and thrusts it into the ground, with their left hand, outside and against the left instep. The bayonet ring is to the front. Marines not armed with the bayonet mark the place with their left heels. This is to mark the rear right corner of the individual's equipment layout. Each member armed with a shoulder weapon lays it on the ground with muzzle to the front, barrel to the left, and butt near the toe of their right foot. The Marines then unslings their equipment and places it on the ground 1 foot in front of their feet. The top of the pack should be to the front and the side that faces rear when worn should be up. All Marines resume attention when finished.

c. At the command "**DISPLAY EQUIPMENT,**" packs are opened and equipment displayed as in current directives. The equipment is displayed in the interval to the left of each Marine. As Marines finish arranging their equipment, each Marine resumes attention in their original position in ranks.

d. The company commander returns to the first platoon after inspecting the arms of the last. The company commander passes along the ranks from right to left as before. When finished inspecting the platoon, the Company Commander directs the platoon commander to have the packs rolled and proceeds to the platoon commander of the next platoon to be inspected. The post and his/her action of the platoon commander during the company commander's arrival and departure is the same as described in paragraph 2.b. of this chapter.

e. The platoon commander then commands "**ROLL PACKS.**" Each Marine assembles their equipment and rolls their pack. The member places it in front of themselves, as described in paragraph 3.b. of this chapter and comes to attention.

f. After all equipment is assembled and packs are rolled, the platoon commander commands "**SLING EQUIPMENT.**" All Marines sling packs, fasten belts, and take arms. They then assume their original place in formation, at attention and order arms.

g. The platoon commander then causes the platoon to close interval and then close ranks, after which he/she gives "**REST**" or "**AT EASE.**"

h. In units such as weapons or headquarters and service companies, which have special combat equipment, the company commander, after packs have been opened, or after individual inspection, directs "**DISPLAY MACHINE-**

GUN, MORTAR, or other EQUIPMENT. Gun teams/squads under the direction of their leaders break ranks and lay out their weapons and accessories for inspection as described in the gun drill for that particular weapon. Headquarters personnel lay out their fire control, communication, or other equipment in a similar manner. Such equipment will be displayed three paces from the right of the squad's flank. The rear of the equipment is placed on line with the rear of the individual field equipment.

4. Inspecting Officer Other Than Company Commander. Should the inspecting officer be other than the company commander, the latter will face the original front of the company after commanding "**AT EASE.**" Upon the approach of the inspecting officer, the inspection proceeds as previously explained. The company commander follows the inspecting officer.

5. Battalion Inspections

a. The battalion is formed in column of companies with companies in line or battalion in line with companies in line, as prescribed in enclosure 1, chapter 11. Before the inspection, the battalion commander indicates whether crew-served weapons and special equipment are to be displayed. They may be laid out at the armory or left on their transportation for subsequent inspection.

b. When the companies are in position, the battalion commander commands "**PREPARE FOR INSPECTION.**" At this command, all companies prepare as described in paragraph 2 of this chapter. The color guard proceeds to a position three paces to the rear of the battalion staff.

c. The battalion commander then commands "**REST,**" returns sword if so armed, and inspects battalion staff and color guard. The staff members come to attention without command, upon the battalion commander's approach, and execute order sword. When the battalion commander approaches the color guard, after inspecting the staff, the staff members return sword and accompanies the battalion commander. The senior color bearer brings the color guard to attention. The battalion commander may dismiss the color guard as soon as inspected.

d. The battalion commander, beginning at the right of the line or at the head of the column, inspects the arms, equipment, dress, and appearance of the personnel in each company.

e. As the battalion commander approaches each company, its commander calls it to attention, faces the front, and salutes. As soon as the company commander has been inspected, the company commander gives the unit "**REST,**" returns sword if so armed, and accompanies the battalion commander during the inspection. The inspection proceeds as described in paragraph 2 of this chapter.

f. The battalion commander may direct the company commanders to make the detailed inspections of their own companies, in which case the battalion commander will usually spot check individuals throughout the battalion. In such a case, all Marines react as described in paragraph 2.b. of this chapter upon the approach of the battalion commander. The battalion commander may also direct members of the battalion staff to inspect individual companies, in which case company commanders react as described in paragraph 2 of this chapter.

g. After a company has been inspected, unless otherwise directed, it may be marched from the field and dismissed.

h. When desired, the battalion commander may direct companies not being inspected to fall out, and wait their turn in the immediate vicinity. In this case, company commanders so instructed must fall their Marines in and prepare for inspection in time so as not to delay the entire inspection.

i. If the inspecting officer is other than the battalion commander, the latter prepares the battalion for inspection in the same manner. Upon the approach of the inspecting officer, the battalion commander brings the battalion to attention, faces the front, and salutes. After being personally inspected, the commander gives the battalion "**REST**," returns sword if so armed, and accompanies the inspecting officer. The inspecting officer proceeds as previously prescribed for the battalion commander.

6. Regimental Inspection. Only in an exceptional situation will an entire regiment be inspected in one formation. However, when held, the principles are the same as for the battalion. The regiment may be formed in any manner suitable to the available space and ground. Battalions are prepared for inspection as described in paragraph 5 of this chapter. Upon the approach of the inspecting officer, each battalion commander brings their unit to attention and salutes. Battalion inspections then follow.

7. Inspection of Quarters or Camp

a. General. In quarters, the Marines stand near their respective bunks uncovered and without equipment or arms. In camp or bivouac, they stand outside their tents covered but without equipment or arms. If the inspection of individual equipment and/or clothing has been ordered, each Marine arranges the required articles as described in current directives.

b. Battalion. During the inspection of the quarters or camp of a company, the battalion commander is accompanied by the company commander and preceded by the first sergeant. The first sergeant sounds "*Attention*" as the inspecting party approaches. Such other officers as may be designated accompany the battalion commander on the inspection.

c. Regimental. The procedure is the same as outlined in paragraph 7.b. of this chapter above. The regimental commander is accompanied by the battalion commander and commander of the company being inspected.

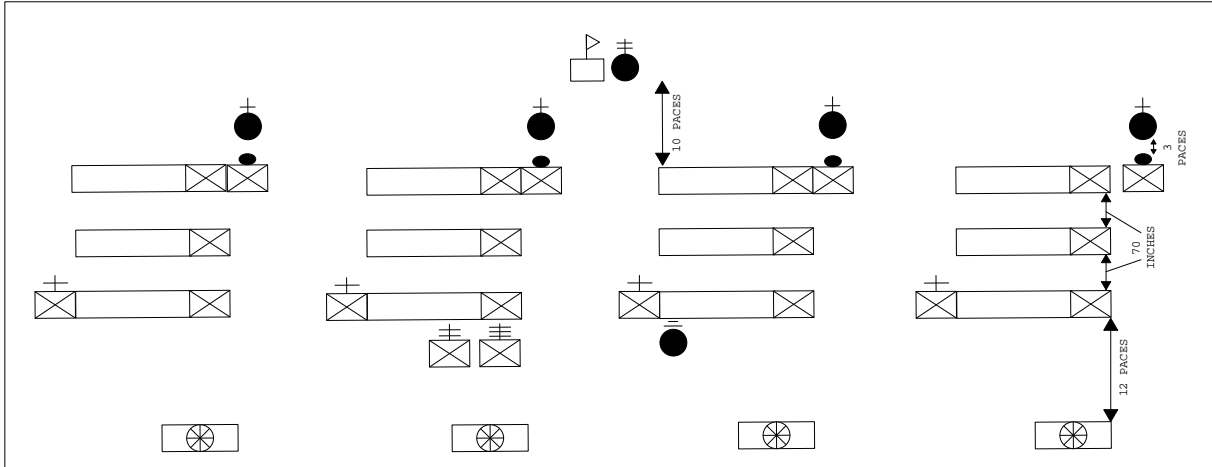

Figure 1-1.--Company Formed for Inspection, Company in Line.

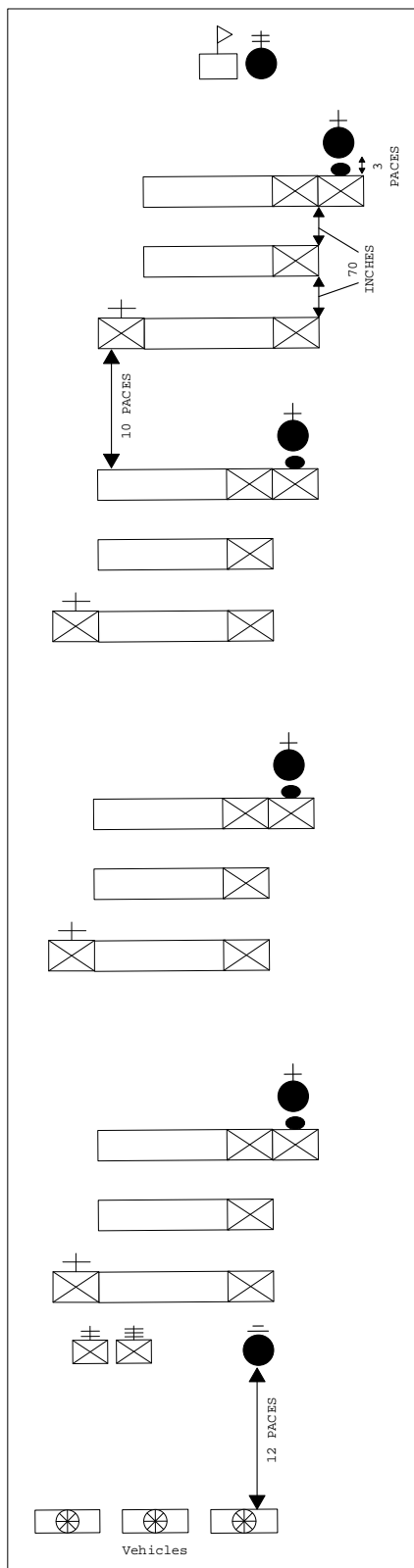

Figure 1-2.--Company Formed for Inspection, Company Column of Platoons in Line.

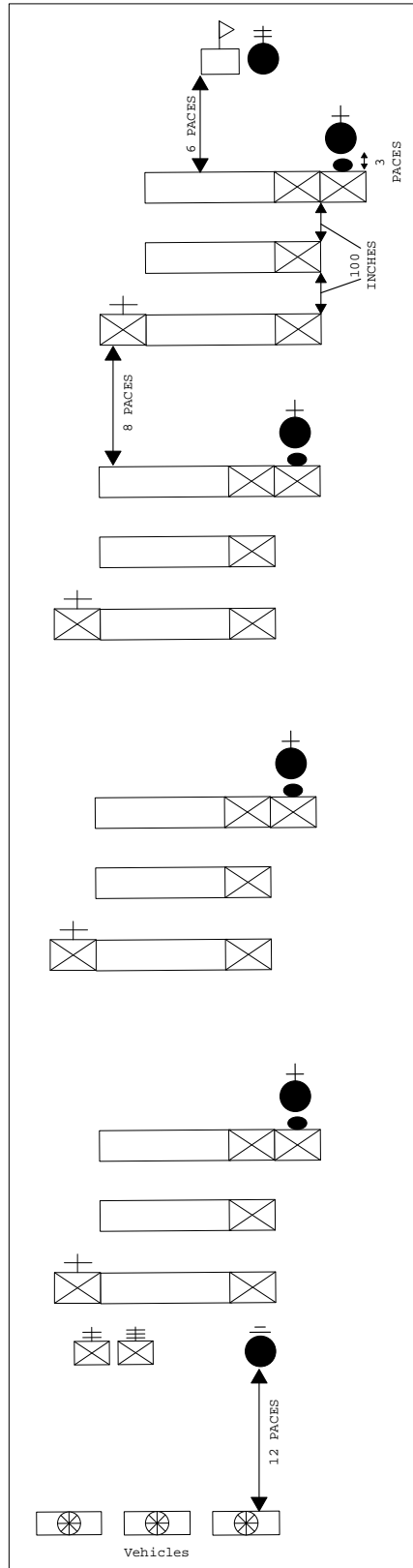

Figure 1-3.--Inspection of Personal Field Equipment in Ranks.

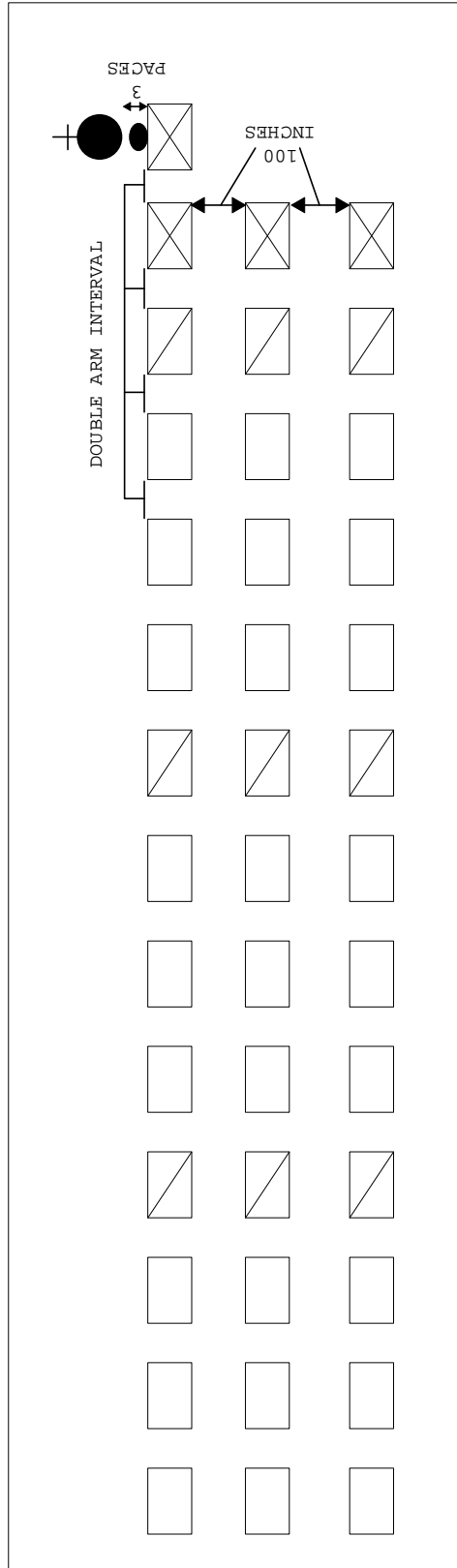

Figure 1-3a.--Inspection of Personal Field Equipment in Ranks, Platoon Spacing.

Chapter 2

Organizational and Parade Staff

TABLE OF CONTENTS

<u>IDENTIFICATION</u>	<u>TITLE</u>	<u>PAGE</u>
1.	General.....	2-2
2.	Forming the Staff.....	2-2
3.	Staff Salutes.....	2-4
4.	Movements of the Staff.....	2-4
5.	Dismissing the Staff.....	2-10
Figure 2-1	The Staff.....	2-2
Figure 2-2	Staff Fall In.....	2-3
Figure 2-3	March on the Staff.....	2-3
Figure 2-4	Turning Movements.....	2-5
Figure 2-5	Boxing the Staff.....	2-6
Figure 2-6	Movements of the Staff when Colors are brought Forward.....	2-8
Figure 2-7	Movements of the Staff for Posting the Colors.....	2-9
Figure 2-8	Marching in Review.....	2-10

Chapter 2

Organizational and Parade Staff

1. General

a. The staff officers of a commander form two paces to the commander's rear in one rank, at normal interval. Enlisted personnel form two paces to the rear of the commissioned officers in one rank, at normal interval. If only one staff officer is present, he/she is posted one pace to the right and two paces to the rear of the commander. Staff officers are arranged with the adjutant on the right and the S-2, S-3 and S-4 to the left in that order, however the commander may arrange them in any order. Enlisted personnel forming with the staff ordinarily are posted by seniority of grade from right to left. (See figure 2-1.) When enlisted personnel, (e.g., a staff noncommissioned officers or noncommissioned officers), conduct a parade or ceremony, the staff will consist only of enlisted.

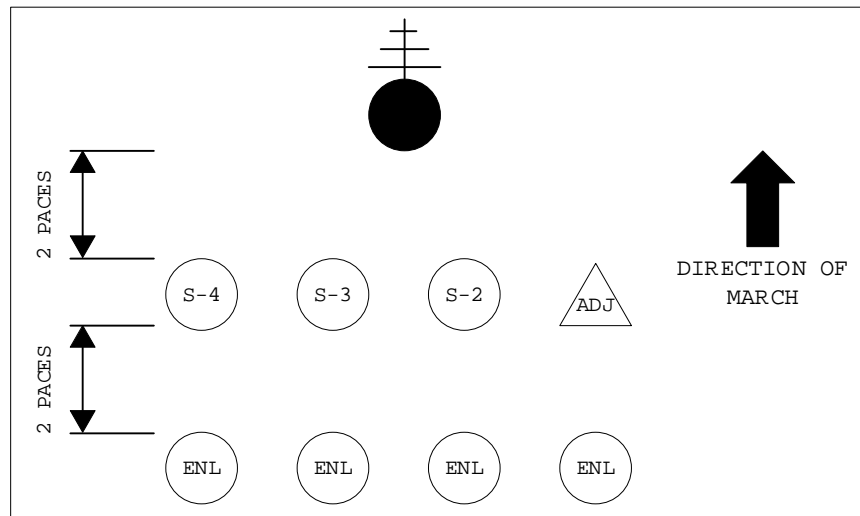

Figure 2-1.--The Staff.

b. All commands for the staff is preceded by the word **"Staff"** (e.g., **"Staff, Draw, SWORD"** and **"Staff, Eyes, RIGHT"**). Commands for the staff are given only loudly enough for the staff to hear in order to prevent the formation from prematurely executing a command. When giving sword commands to the staff, the commander of troops will always be at the same sword position as the staff and execute with them. During ceremonies without swords, the commander of troops will execute movements as a member of the staff. When armed with a sword, and giving commands that do not involve sword movements, the commander of troops will deliver commands at carry sword. At no time during a ceremony will the commander of troops turn his/her head left or right to give a command.

2. Forming the Staff

a. Prior to forming, the staff may be positioned together on either side of the reviewing area or split on opposite sides, depending on the layout of the reviewing area/parade field and the commander's discretion.

To form the staff for a parade or other ceremony, the commander moves to a position in front of the reviewing stand and centered between the dress guidons, halts facing the reviewing area and commands "**Staff, FALL IN.**" The members of the staff move from their positions and form in front of, centered on, and facing the commander. When the staff falls in, they do not raise their arms nor turn their heads and eyes to the right for alignment. Once the staff is in position the commander does an about face and faces the line of troops. (See figure 2-2.)

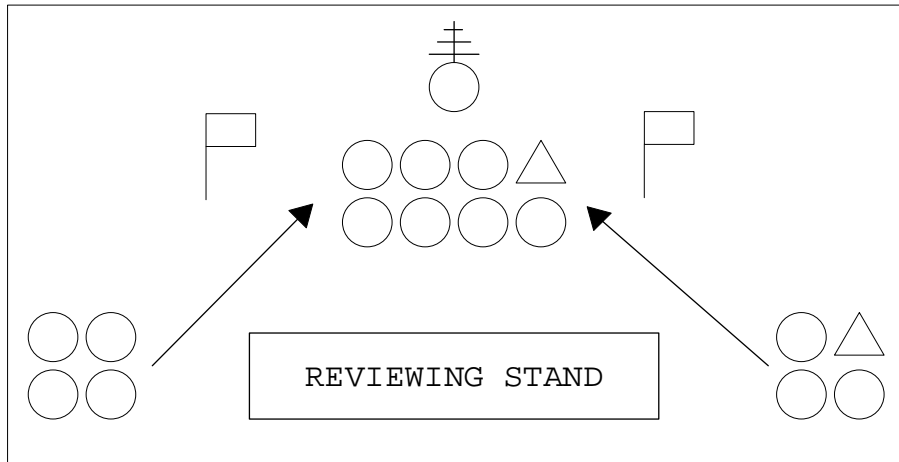

Figure 2-2.--Staff Fall In, from the flanks.

b. The staff, on the first note of the music following "*Adjutant's Call,*" march forward on command of the commander of troops from their position in front of the reviewing area to a post midway between the reviewing area and the line of troops and halt facing the line of troops. (See figure 2-3.) If armed with swords, they remain in the scabbards.

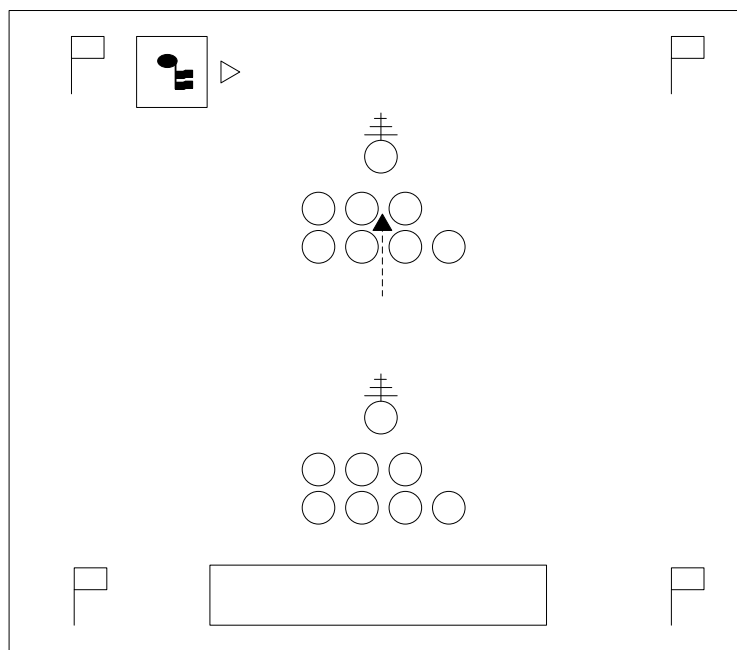

Figure 2-3.--March on the Staff.

c. The staff draws sword on the command of the commander. For the senior staff of a formation or parade, this is done after the adjutant has formed the parade, reported to the commander and taken his/her post in the staff. The commander then commands "**Staff, Draw, SWORD**" and "**Staff, Order, SWORD.**" The commander remains at the carry. The staffs of subordinate commanders draw swords prior to marching the unit onto the field. The staff(s) remains at order sword except when:

- (1) Boxing the Staff.
- (2) Moving to clear a path for the colors to be brought forward.
- (3) When at present, parade rest, at ease or rest.
- (4) Passing in review or any other marching or facing movements that require the staff to move.
- (5) The staff, including the staffs of subordinate commanders, remains at the order during the manual of arms.

d. During regimental/group parades, at officers center all battalion/squadron commanders and their staff's close center on the original line of battalion/squadron commanders. Additionally, during division/wing parades the regimental/group commanders and their staffs, in addition to the battalion/squadron commanders and their staffs, close center on the original line of regimental/group commanders.

3. Staff Salutes. Members of the staff salute with the commander, on the commander's separate command to the staff at the following times:

- a. When passing in review.
- b. When rendering honors.
- c. When passing the national colors or the national colors pass to its front.

d. While the "*National Anthem*," "*To The Colors*" "*Hail to the Chief*," "*Taps*," (when played for memorials) and other musical salutes that require a salute is played. Salutes are also rendered when "*Retreat*" is played during reviews and all ceremonies, except at evening parade. At evening parade, "*Retreat*" is played immediately after "*Sound Off*" while the troops are at parade rest, and is therefore not saluted. In this case, after "*Retreat*," troops are brought to attention and salutes are rendered while the "*National Anthem*" is played to lower the national ensign.

- e. At any other time the troops are brought to present arms.

4. Movements of the Staff

a. The staff marches two paces to the rear of the commander in two ranks. The staff changes direction by making turning movements vice column movements. The staff only marches in column when boxing the staff and when moving to the side in order to allow the color guard to march forward. The staff aligns to the right, except when making a turn, when the alignment shifts to the direction of the turn.

b. When the commander faces to the right (left) and marches off, the staff follows by making a turning movement. The command is **"Staff, Right (Left) Turn, MARCH."** (See figure 2-4.)

c. While halted, on the command "March," the extreme right (left) flank staff member will begin marking time while rotating towards the direction of the turn. Once faced in the new direction, the extreme flank member will begin to half step. The remaining members of the staff will begin to half step until they face the new direction of march. Upon completion of the turn, the staff will be aligned and half stepping in the new direction. The COT will immediately give the next command, such as "Forward, MARCH." While marching when turning to the left, the command of execution is given on the right (when turning to the right, the command is given when the left foot strikes the deck). On the command "March," all members of the staff with the exception of the extreme left flank member will take one more 30 inch step with their left foot, their next step will be a 15 inch step with the right foot. The left staff member, will take one more 30 inch step with their left foot and begin to mark time acting as a stationary pivot point, the staff turns to the left while half stepping until they face the new direction. When making the turn, all members of the staff face the same direction. Upon completion of the turn the staff will be aligned half stepping in the new direction. The COT will immediately give the next command, such as "Forward, MARCH."

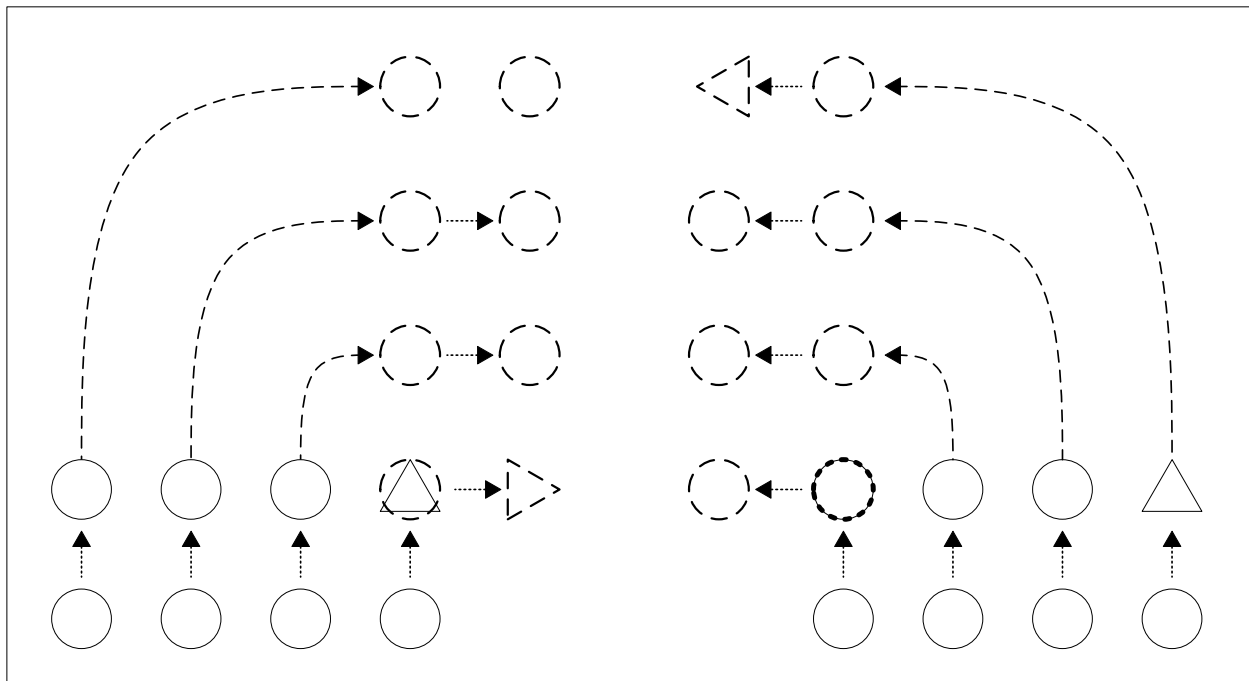

Figure 2-4.--Turning Movements.

d. During parades and other ceremonies when it is prescribed for the staff to change its position in order to place itself in the rear of the battalion commander, the commander will order the adjutant (or senior staff officer) to **"BOX THE STAFF."** The adjutant would then give the following commands to the staff in order to place them to the rear of the commander.

(See figure 2-5.)

- (1) **"Staff, Carry, SWORD"** (if armed with swords).
- (2) **"Staff, Left, FACE."**
- (3) **"Staff, Column Right, MARCH."** (Second column right is executed without command. Once each staff member has reached their new position they automatically mark time.)
- (4) **"Staff, HALT."**
- (5) **"Staff, Right, FACE."**
- (6) **"Staff, Order, SWORD"** (if armed with swords).

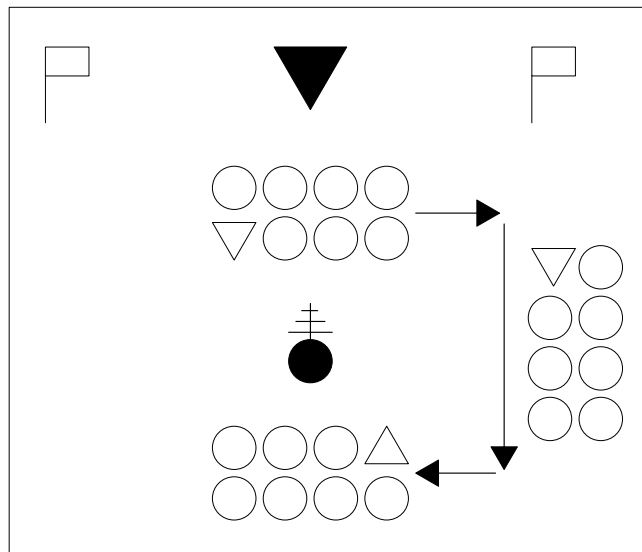

Figure 2-5.--Boxing the Staff.

e. During a parade or ceremony that requires the colors are brought forward the staff moves to one side (see figure 2-6, left side) on the commanders command of **"Marine, Officer, Personnel to be Decorated, be Retired, etc., and All Colors, Center, MARCH"** in the following sequence: (This command is always given while facing the line of troops).

(1) On the commander's command of **"Colors,"** the staff executes carry swords (if armed with swords).

(2) On the commander's command of **"Center,"** the staff executes a right face.

(3) On the commander's command of **"MARCH,"** the staff steps off and marches forward 8-10 paces. (The commander steps off towards the color guard after the staff have cleared.) At the completion of their 8-10 paces, the staff halts on their own and faces left without command.

NOTE: The staff does not salute the colors when they pass their position since the colors are passing the staff's flank and not the staff's front.

f. The commander marches forward to the color guard, halts, and salutes the colors and faces about. The commander then marches the color guard forward to the reviewing stand and halts. The Marines to be recognized then move to their position between the commander and color guard, unless marched forward with the color guard. (See enclosure 2, chapter 6.)

g. The staff returns to its original position (see figure 2-6, right side) after the color guard has halted using the following commands given by the adjutant:

(1) **"Staff, Left, FACE."**

(2) **"Staff, Forward, MARCH"** (8-10 paces). At the completion of their 8-10 paces, the staff halts on their own and faces right without command.

(3) **"Staff, Order, SWORD"** (if armed with swords).

h. Once the Marines to be recognized are present (see enclosure 2, chapter 6) and the staff is back in its position, the commander salutes the reviewing officer and states, **"Sir/Ma'am, Marine, Officer, or Personnel to be _____, and all Colors are Present."**

(1) The reviewing officer returns the salute and directs the commander to **"Present the Command."**

(2) The commander, goes to carry sword, steps right in marching and moves to a position between the staff and color guard (saluting the colors as he/she passes them), halts facing the line of troops and commands the unit to **"Present, ARMS."** (See figure 2-6, right side.)

(3) The commander then faces the reviewing officer and gives the command **"Staff, Present, SWORD (ARMS)."** The staff, color guard and Marines being recognized salute.

(4) After the last note of the music, the commander would command **"Staff, Order, SWORD (ARMS)."** The staff, color guard and Marines being recognized terminate their salutes.

(5) The commander then faces about and gives the command of **"Order, ARMS"** to the formation.

(6) The next command would depend on the particular sequence of events for that particular ceremony.

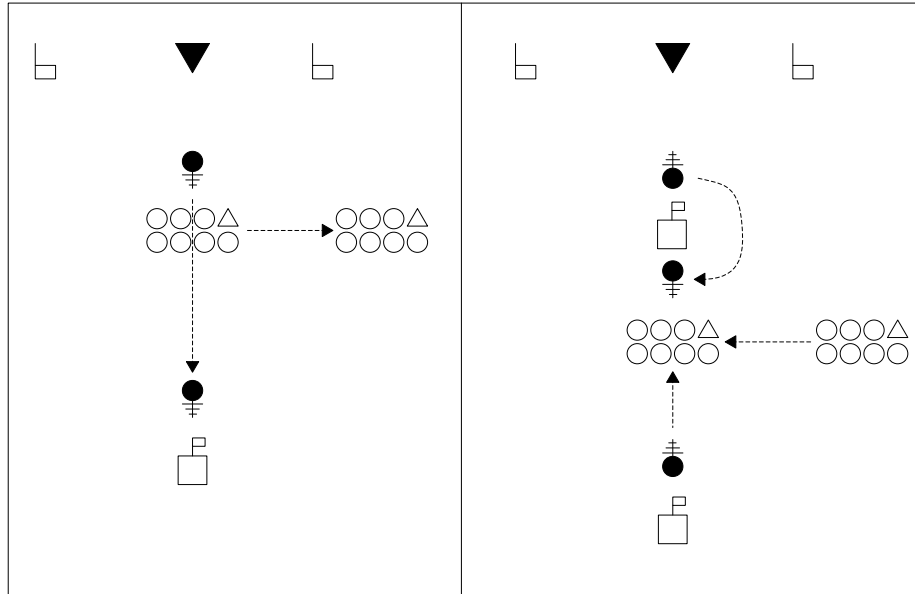

a. Left Side.

b. Right Side.

Figure 2-6.—Movements of the Staff When Colors are Brought Forward.

i. Once the awards ceremony is completed, the commander causes the color guard to return to the line of troops (see figure 2-7, left side), and Marines being recognized to move to their next position by giving the following commands: **"Post the Colors."**

(1) **"Staff, Carry, SWORD,"** (if armed with swords) the staff goes to carry swords; the color guard goes to carry colors.

(2) **"Staff, Right, FACE,"** the staff executes a right face the award recipients execute a left face.

(3) **"Staff, Forward, MARCH,"** the commander and staff march forward 8-10 paces, halts on their own and faces left without command. The staff remains at carry sword if armed with swords. The color guard executes a countermarch and returns to its position on the line of troops. The Marines being recognized move to their designated position. (See enclosure 2, chapter 6.)

j. The commander returns the staff to its original position after the color guard has cleared that position (see figure 2-7, right side) using the following commands:

(1) **"Staff, Left, FACE."**

(2) **"Staff, Forward, MARCH"** (8-10 paces). At the completion of their 8-10 paces, the staff halts on their own and faces right without command.

(3) **"Staff, Order, SWORD,"** (if armed with swords). When the color guard is in position, and at the order, the commander faces the reviewing officer and awaits the next command. (Normally to **"MARCH THE COMMAND IN REVIEW."**)

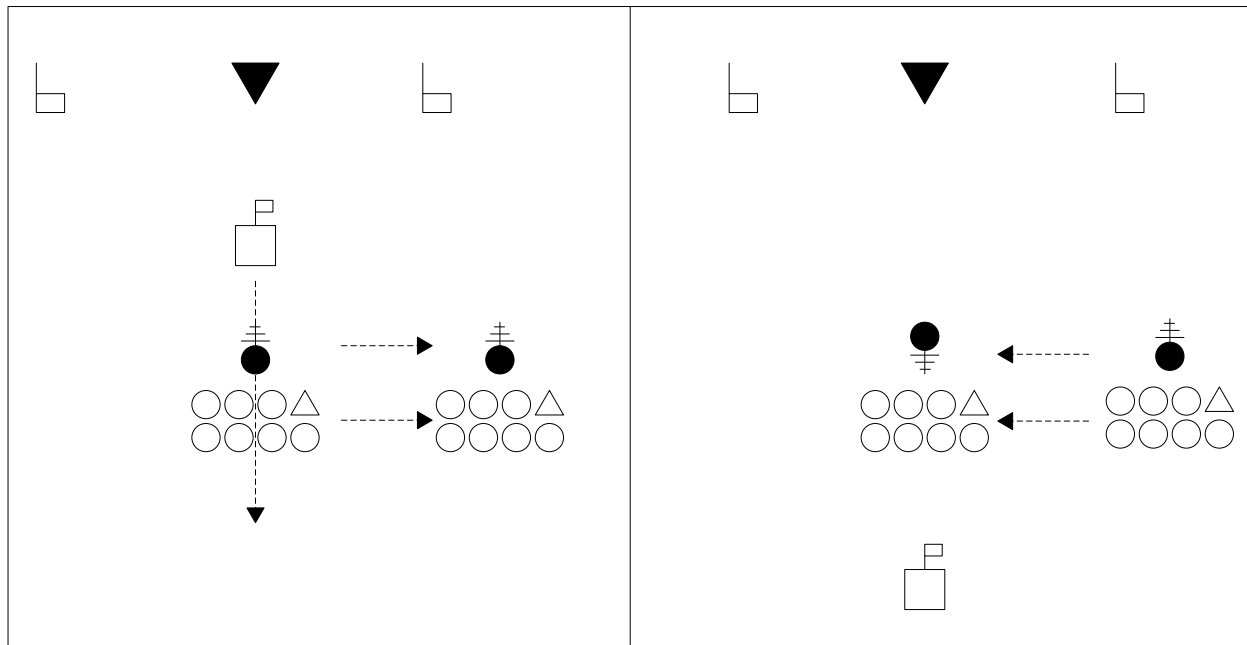

a. Left Side.

b. Right Side.

Figure 2-7.--Movements of the Staff for Posting the Colors.

k. When the commander receives the command to **"MARCH THE COMMAND IN REVIEW,"** after exchanging salutes with the reviewing officer, the commander faces the line of troops and gives the command to **"PASS IN REVIEW."**

(1) The command is prepared to pass in review per the selected sequence of events.

(2) The commander and staff step off when the command of execution **"MARCH"** is given by the commander of the lead element in the parade.

(3) The commander and staff marches down the line and execute two left turns in order to be positioned in front of the band. However, subordinate commanders and staffs that are part of a larger parade unit (e.g., regimental parade) would march parallel to the line of troops and execute a left turn in order to be positioned at the head of their command.

(4) As commanders and staffs approach the reviewing area, each commander gives the command of **"Staff, Eyes, RIGHT (LEFT),"** and as the reviewing area is cleared **"Staff, Ready, FRONT."** When executing eyes right when either armed with a sword or unarmed, all members on the command **"Staff, Eyes, RIGHT (LEFT),"** execute either present sword or a hand salute. All members of the staff turn their heads and eyes to the right (left) except the extreme right (left) file.

(5) The senior commander and staff continue to march down the line of troops to the end of the reviewing area, or other designated point, where they will turn out of the line of march and be positioned to observe the march in review (e.g., they may execute three right turns, see figure 2-8).

(6) Subordinate commanders and their staffs, after marching in

review, would lead their command from the field.

(7) The senior commander, after the staff is halted, commands the staff to "**Staff, Return, SWORD.**" The senior commander gives the commands of "**Hand, SALUTE**" and "**Ready, TWO**" as the color guard(s) pass their position.

(8) After the rear element of the command (normally the band) has passed the staff's position and exited the field, the commander faces the reviewing officer and salutes. After the salute is returned, the commander may:

(a) The commander and the staff draw swords and follow the command from the field.

(b) Dismiss the staff.

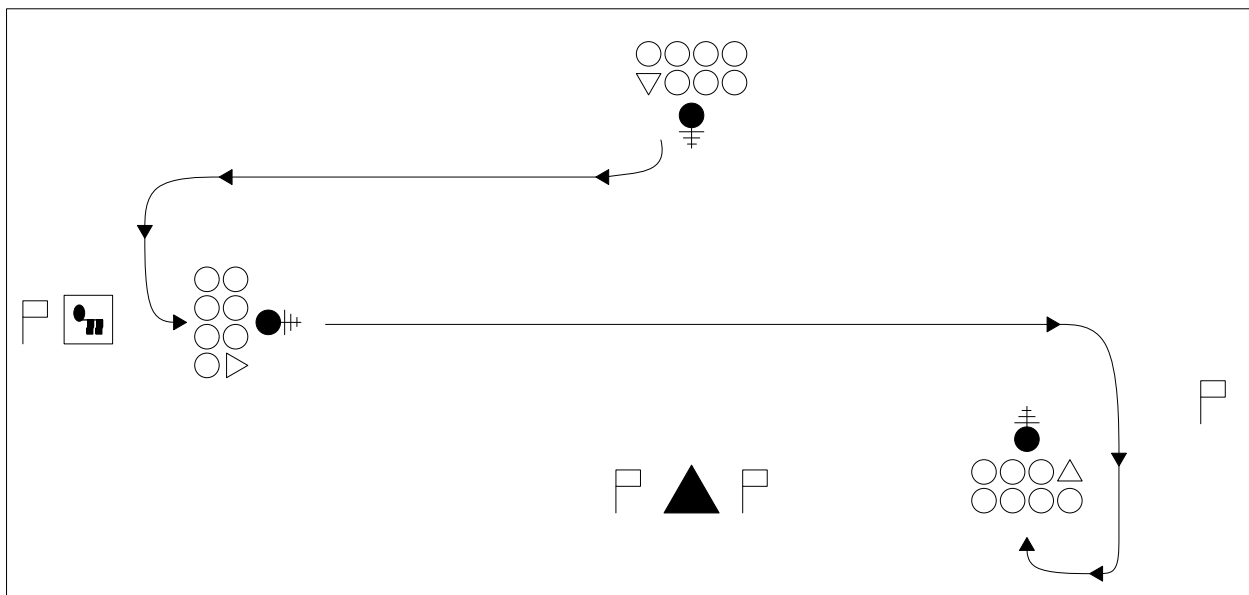

Figure 2-8.--Marching in Review.

5. Dismissing the Staff. When the commander dismisses the staff, the staff must be at attention and swords returned. The commander, facing the staff, commands "**Staff, DISMISSED.**" The staff would take one step to the rear with the left foot, halt and execute a hand salute. The commander would return the salute. The staff would terminate the hand salute, face about and depart smartly from the field.

Chapter 3

General Information

TABLE OF CONTENTS

<u>IDENTIFICATION</u>	<u>TITLE</u>	<u>PAGE</u>
1.	General.....	3-2
2.	Arrangement of Units in Formation.....	3-2
3.	Place of Formations.....	3-4
4.	Organizations and Strength of Units.....	3-4
5.	Commands, Drill Movements, and Unit Formations....	3-4
6.	Uniform and Equipment.....	3-4
7.	Ceremonies Conducted Indoors.....	3-5
8.	Marking Parade Fields.....	3-5
9.	Key Personnel and Rehearsals.....	3-8
10.	Ceremonial Atmosphere.....	3-10
11.	Ceremonial Checklist.....	3-10
12.	Seating Guidance.....	3-15
Figure 3-1	Finding the Center of the Field.....	3-6
Figure 3-2	Sample Marking for Company in Line.....	3-7
Figure 3-3	Sample Marking to Form a Company Mass from a Company Column.....	3-7
Figure 3-4	Sample Marking for the Adjutant, Commander of Troops and Staff.....	3-8
Figure 3-5	Ceremonial Checklist.....	3-11

Chapter 3

General Information

1. General

a. There are numerous occasions for the conduct of a ceremony, but all are special events to celebrate or honor units or deserving individuals. These ceremonies will normally be conducted as a review, parade or indoor ceremony as outlined in enclosure 2, chapters 4 and 5. The following are specific occasions for a ceremony and details for each can be found in enclosure 2, chapters 6 through 11, and enclosure 2, chapters 13 and 14.

- (1) Presentation of decorations and individual retirements.
- (2) Change of command ceremony.
- (3) Relief and appointment of the sergeant major.
- (4) Activation and/or deactivation of a unit.
- (5) Marine Corps birthday cake cutting ceremony.
- (6) Unit mess night or dining-in.

b. Military funerals and memorial services are ceremonies conducted per the provisions of enclosure 2, chapter 13 with the procedures for firing details outlined in enclosure 2, chapter 14.

c. It is a long standing tradition for Marines, past and present, who when they hear the Marines Hymn that they will face the direction of the music and stand at attention. It is now directed that Marines, present and who have served honorably, who are not in a formation or part of an actual ceremony, or marching in a parade or review, who when they hear the playing of the Marines Hymn will stand at attention, face the music and sing the words to the Hymn.

2. Arrangement of Units in Formation

a. In ceremonies involving the U.S. Marine Corps and U.S. Navy units, the Marine unit shall be on the right of line or head of the column. The senior line officer, regardless of service, functions as the commander of troops.

b. In ceremonies involving other services of the United States, the order of formation from right to left in line and front to rear in column is as indicated below. The senior line officer, regardless of service, functions as the commander of troops.

- (1) Cadets, United States Military Academy.
- (2) Midshipmen, United States Naval Academy.
- (3) Cadets, United States Air Force Academy.
- (4) Cadets, United States Coast Guard Academy.

- (5) United States Army.
- (6) United States Marine Corps.
- (7) United States Navy.
- (8) United States Air Force.
- (9) United States Coast Guard.
- (10) Army National Guard of the United States.
- (11) Army Reserve.
- (12) Marine Corps Reserve.
- (13) Naval Reserve.
- (14) Air National Guard of the United States.
- (15) Air Force Reserve.
- (16) Coast Guard Reserve.

(17) Other training organizations of the Army, Marine Corps, Navy, Air Force, and Coast Guard in that order, respectively.

(18) During any period when the United States Coast Guard shall operate as part of the United States Navy, the Cadets, United States Coast Guard Academy, the United States Coast Guard, and the Coast Guard Reserve shall take precedence, respectively, next after the Midshipmen, United States Naval Academy, The United States Navy; and the Naval Reserve.

c. When foreign troops are invited to participate in ceremonies within the territorial jurisdiction of the United States, they will be assigned a position of honor ahead of United States troops. A small detachment of United States troops will immediately precede the foreign troops as a guard of honor.

d. When troops of two or more foreign nations participate, the order of precedence among them will be determined, except for the provisions of paragraph 2.c. of this chapter, by the commander of troops per one of the following methods, whichever is deemed most appropriate:

(1) The relative ranks of the commanders of the forces from which the ceremonial detachments are drawn.

(2) The relative ranks of the commanders of the ceremonial detachments.

(3) The alphabetical order in the English language of the names of the nations concerned.

e. After troops are formed, subordinate commanders and their staffs face front. The commander of troops and the staff face the command. The commander of troops and the staff face front to present the command to the reviewing officer (RO).

3. Place of Formations

a. At "Assembly," companies are formed and inspected by their company commanders at their designated assembly area.

b. At "Adjutant's Call," for a ceremony involving a single battalion, the battalion forms in its assembly area and conducts the ceremony. For a regimental ceremony, at the first "Adjutant's Call," each battalion forms in its assembly area, and the battalion reports to its commander. At the second sounding of "Adjutant's Call," the regiment is formed, and the ceremony is conducted.

c. For ceremonies conducted by organizations larger than a regiment, such as a division, at the second "Adjutant's Call," each regiment is formed and is reported to its commander. At the third "Adjutant's Call," the command is formed and the ceremony is conducted.

4. Organizations and Strength of Units

a. For formations, reviews, and parades when maximum troop participation is desired, units are organized, in as much as practicable, according to their actual tables of organization. Size of units will vary according to actual strengths as will the number of companies in each battalion and platoons in each company. Similarly, the number of ranks in each platoon will vary according to the number of squads. For units not organized by table of organization into squads, they should be formed so that platoons are in three ranks in line and three files in column.

b. When the appearance of troops in formation is of primary concern, the organization and strength of participating units should be standardized. Each platoon should be organized so as to form in three ranks in line and three files in column. The strength of each platoon should be the same so that, when in line, all platoons occupy the same frontage.

5. Commands, Drill Movements, and Unit Formations

a. During ceremonies, unit commanders give commands, units execute drill movements, and units employ formations as prescribed for squad, platoon, company, battalion and regimental drill.

b. Commanders may modify formations for ceremonies when the nature of the ground or exceptional circumstances requires such changes. Normally, modifications are generally limited to adjusting the paces specified for intervals and distances in a given formation to fit the ground used for conduct of the ceremony.

6. Uniform and Equipment. The organization, uniform, arms and equipment of units participating in ceremonies, along with any other necessary administrative information, are prescribed by the commander of troops, or may be prescribed by unit standing operation procedure to preclude the necessity of frequent repetition in individual ceremony orders. Commanders will not designate any of the above when it will be in direct violation of other applicable Marine Corps orders, (i.e., Marine Corps Uniform Regulations).

7. Ceremonies Conducted Indoors

a. In addition to reviews and parades conducted per enclosure 2, chapters 4 and 5, there will be occasions when an indoor ceremony would be more appropriate or necessary, as is the case during inclement weather. Indoor ceremonies can be conducted for change of command, relief and appointment of the sergeant major, awards, retirement, activation and deactivation of units, honors, promotions, and the graduation of formal schools. If the ceremony is conducted in a large structure such as a gymnasium or hanger, many of the elements of a review or parade may be used. However, if the location for the indoor ceremony is a banquet hall, theater, auditorium, or classroom and space is limited, then the ceremony will be modified using the following guidelines. At a minimum, the indoor ceremony may contain the following elements in the order shown.

(1) Pre-ceremony music (optional).

(2) Invocation (optional).

(3) "National Anthem" (see paragraph 7.b. of this chapter).

(4) Honors (as required).

(5) At this point, the ceremony will proceed depending on the occasion. Colors are passed for a change of command; the sergeants major are relieved and appointed; awards, retirements and promotions are effected; diplomas or certificates for graduations are delivered.

(6) Remarks if appropriate (remarks may also be done prior to the procedures outlined in paragraph 7.a.(1) of this chapter above for graduation ceremonies).

(7) Benediction (optional).

(8) "*Anchors Aweigh*" and "*Marines' Hymn.*"

b. Color Guard. For indoor ceremonies, the color guard may be omitted and colors pre-staged in flag stands per the procedures in enclosure 1, chapter 7. If colors are used, the procedures outlined in enclosure 1, chapter 7, section 3, paragraph 8 will be followed.

c. When special circumstances, such as the use of gymnasiums, hangars, and hangar bays dictate, the commander may direct that participants remain covered and render appropriate salutes as required for the particular ceremony. In such instances, commanders will detail the specific requirements for remaining covered and rendering appropriate salutes.

8. Marking Parade Fields

a. Parade fields may be marked using paint, chalk, circular markers (coffee can lid) or any other means at the unit's disposal. Conditions and type of surface of the parade field must also be taken into consideration prior to marking. For instance, if a grass field is used, and it is to be mowed prior to the ceremony, then paint would be a better choice than circular markers, which may damage mowing equipment. Additionally, if more than one unit of a different size uses the parade field, chalk may be a better option than paint.

b. The line on which troops are to form and along which they are to march is marked out or otherwise designated by the unit's sergeant major or senior enlisted assisted by the unit's G/S-3. The post of the RO, opposite the center of the line of troops, is marked on each flank with a dress guidon that is six paces from the line of march. The corners of the parade field are also marked with dress guidons. Additionally, the posts of the commander of troops, adjutant(s), subordinate unit commanders, guides, the color guard, officers center and turning points should be marked.

c. To begin marking a field for a ceremony, first determine the location of the RO; this becomes the centerline for the field. From the RO's location, move approximately 100 paces directly to the front. This spot is the location of the color guard that should always be centered on the RO's spot. Begin marking the line of troops from the color guard's spot outboard to ensure the formation is symmetrical. (See figure 3-1.)

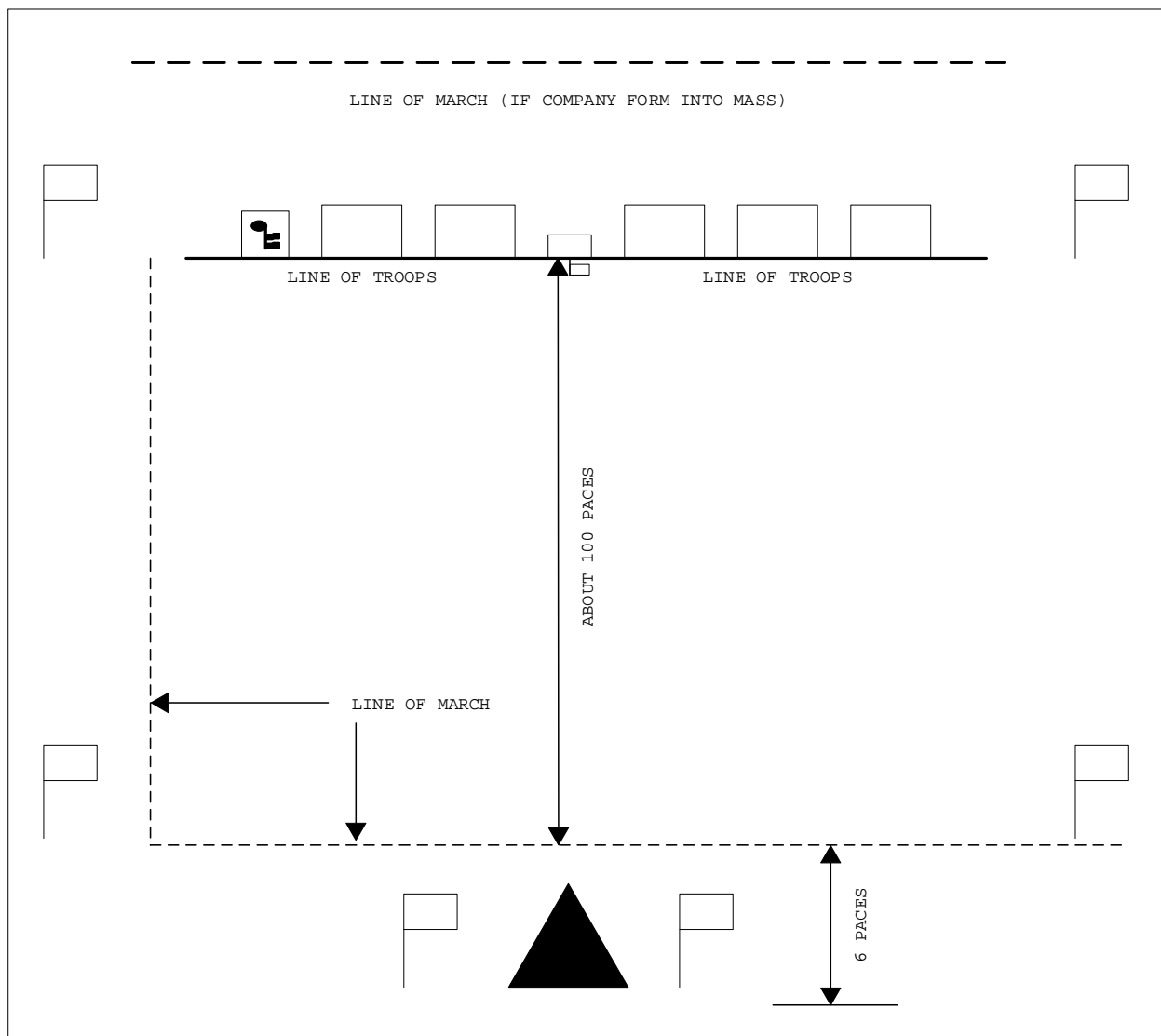

Figure 3-1.--Finding the Center of the Field.

d. The next positions to be marked are where the subordinate units are to come to rest on the line of troops. For a battalion size unit, the minimum markings are, guide on line, squad leaders, platoon commanders, company guides and company commanders. Examples of markings for a company in line, platoons on line are shown in figure 3-2. Examples of markings for forming a company in mass from a company in column are shown in figure 3-3.

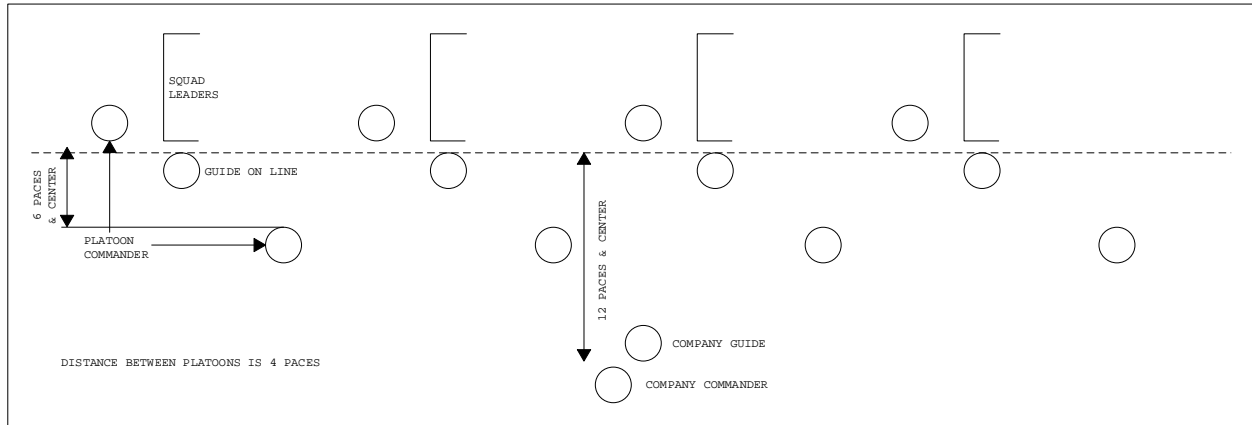

Figure 3-2.--Sample Marking for Company in Line.

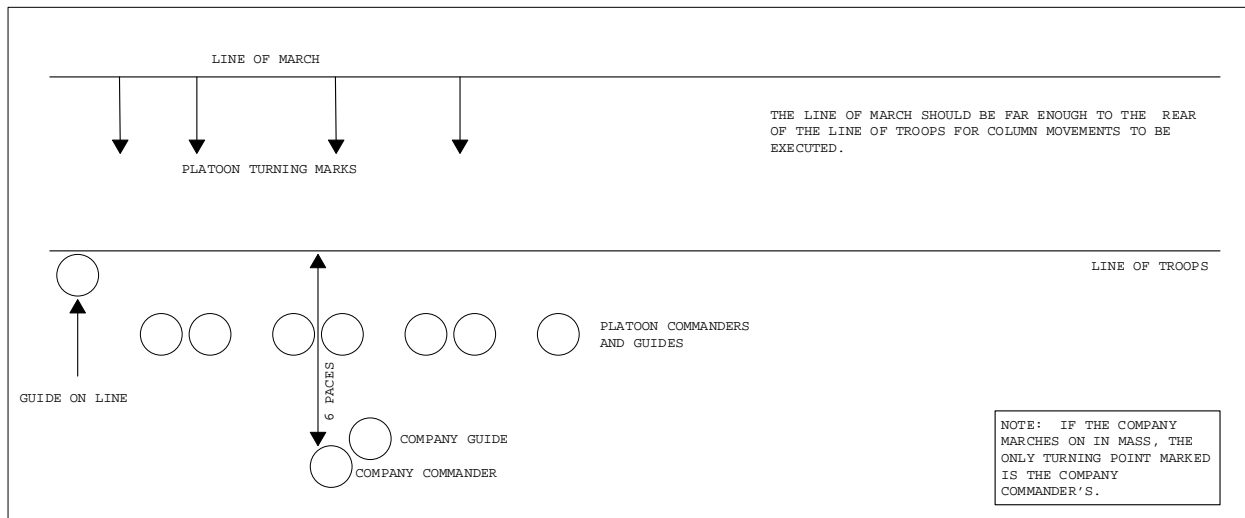

Figure 3-3.--Sample Marking to Form a Company Mass from a Company Column.

e. After the positions for all marching elements of the ceremony are marked the positions of the adjutant, commander of troops and staff to include subordinate commanders and staffs. (See figure 3-4.)

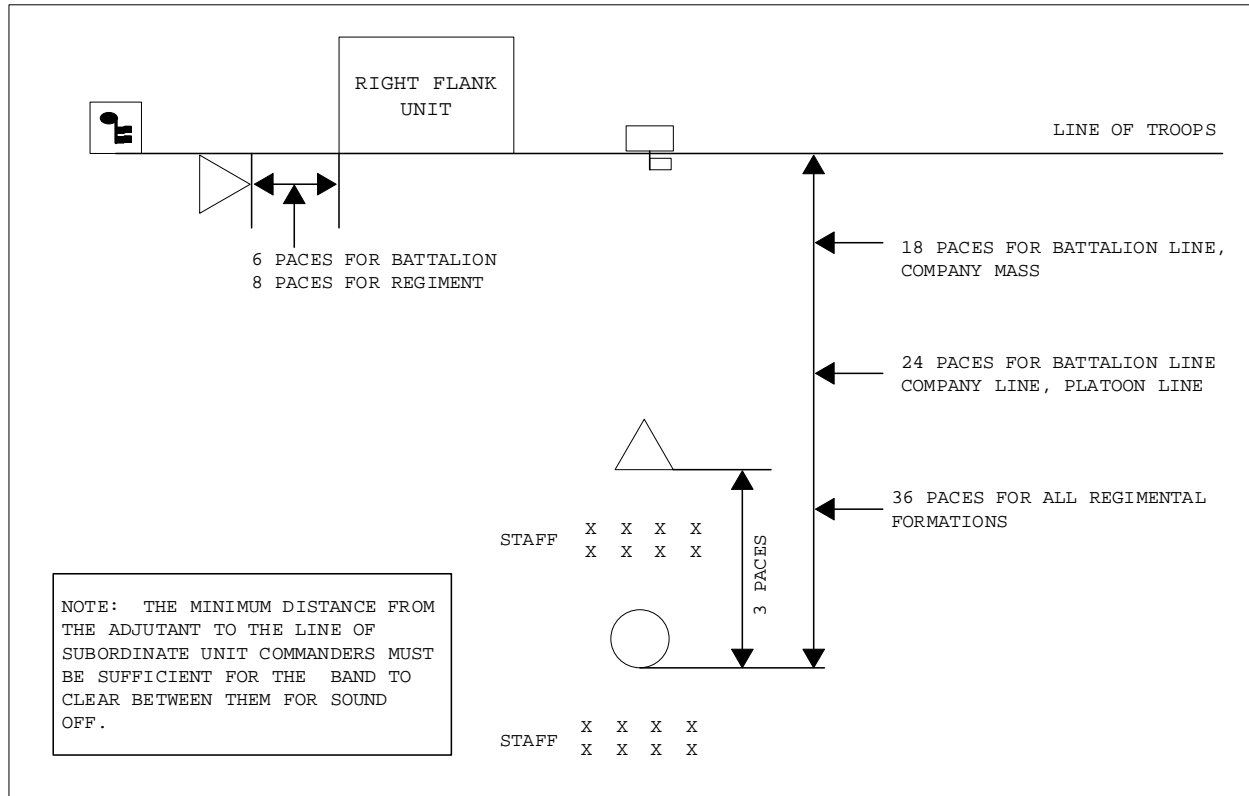

Figure 3-4.--Sample Marking for the Adjutant, Commander of Troops and Staff.

f. The final marking would be for officer's center. During officer's center, battalion commanders, and their staffs, company commanders, company guides and platoon commanders march directly to the center from their position in formation at the command march. Company commanders oblique slightly forward so that they are four paces ahead of the line of company guides. Usually a single long line (with Xs where the officers/guides halt) for each rank is marked on the field.

g. The minimum personnel needed to assist marking the field is the same as the number of Marines that comprise the "front" of each unit in the formation, plus two. For example to mark a company in line, platoons in line, 15 Marines are needed, 13 to mark the squad front, one for the platoon commander's position, and one for the platoon sergeant's position, in order to get the appropriate four paces between the platoons.

9. Key Personnel and Rehearsals

a. While not inclusive, the key personnel for parade rehearsals normally consist of the following:

- (1) Commander of troops and staff.
- (2) Adjutant(s).
- (3) Subordinate commanders and staffs.
- (4) Color guard.

- (5) Company commanders.
- (6) Company guides.
- (7) Platoon commanders.
- (8) Platoon sergeants.
- (9) Platoon guides.
- (10) Squad leaders.
- (11) Award recipients/retirees etc.
- (12) Narrator.

b. In order to conduct a successful parade or ceremony, sufficient rehearsals must be conducted. Normally, due to transportation; time spent drawing weapons; etc., only one all hands rehearsal is needed. The Marines participating in formation should be drilled in the manual of arms, marching in review, etc., in their company area in order to preclude excessively long or multiple all hand rehearsals. Key personnel are rehearsed exhaustively since they will make or break a parade or ceremony.

c. Key personnel rehearsals are usually scheduled in two hour blocks. The reason is that most parade sequence of events, less awards, speeches, etc., last from 35-45 minutes, depending on the size of the unit. Scheduling two hour blocks for rehearsals allows sufficient time to go over the sequence at least twice per rehearsal period. Normally key personnel rehearsals are conducted as follows:

(1) The initial key personnel rehearsal is more of a class or "chalk talk" than an actual rehearsal. This chalk talk should clear up any fine points of the ceremony as well as clearly establish who is in charge of the parade. The key personnel are briefed by senior enlisted concerning all aspects of the sequence of events for the parade as well as refresher training on the following:

- (a) The movements of the adjutant.
- (b) The movements of the commander of troops and staff.
- (c) The movements of the platoon commanders on dress right.
- (d) The movements of the guides on guides post.
- (e) The sword manual if so armed.

(f) If armed with swords, the officers and company guides are shown how to do a four-count halt at officers center.

1. On the first two counts, the officers and guides execute a halt.

2. On the third count, the officers execute the first count of present swords.

3. For the fourth count, the officers execute the second count of present swords and the company guides present guidons.

(g) If not armed with swords, the officers and company guides are shown how to do a four-count halt at officer's center.

1. On the first two counts, the officers and guides execute a halt.

2. On the third count, all members will pause.

3. On the fourth count, the officers execute a hand salute, and the company guides present guidons.

(h) The officers and company guides are shown the movements to return from officers center.

(i) Passing in review.

(2) The second key personnel rehearsal should be a walk-through of the sequence of events without repeating movements incorrectly executed. This rehearsal's sole purpose is to establish the sequence of events in the minds of all key personnel.

(3) Third and subsequent key personnel rehearsals work on the polish of each movement made during the parade and ceremony. (e.g., officers center, dress right, box the staff, etc.)

10. Ceremonial Atmosphere. On the day of the ceremony, it is appropriate to create something called "Ceremonial Atmosphere." This should be done approximately 45 minutes prior to the ceremony. At this time, all fixed installations should be in place to include, dress guidons, the firing battery, tentage, seating, etc. If there are buildings adjacent to the ceremony area then care must be taken to place windows, blinds, and curtains in the same position for uniformity. Excess gear should be removed. Sentries should be posted to prevent persons from entering the ceremonial area during the period when the ceremony is being conducted.

11. Ceremonial Checklist. Figure 3-5 is a sample ceremony execution checklist that can be used when planning various types of ceremonies. It is based on a 60-day reverse planning timeline. This sample can be modified to fit local requirements and timelines.

DATE	SECTION	ACTION REQUIRED	REMARKS
C-60	CG/CO	Identify type of ceremony and date of event	
C-58	G/S-3	Request band for ceremony and to provide taped music for rehearsals. Ensure band support includes one rehearsal and a 20-minute concert prior to the start of ceremony.	
C-45	G/S-3	Publish 5060 bulletin or LOI.	
C-45	G/S-1	Request guest lists as appropriate for those being honored.	
C-40	G/S-3	Chair parade coordination meeting.	
C-30	G/S-1	Consolidate guest list and mail all invitations. Prepare RSVP roster for use by phone watches.	
C-30	G/S-1	Acquire biographies and photographs for those being honored for inclusion in the program.	
C-30	G/S-1	Submit proposed program for review.	
C-30	G/S-3	Request photographic coverage, still and video from local CVIC.	
C-30	G/S-3	Request "Quiet Hours" from appropriate agencies.	
C-30	G/S-1	Prepare a "Narration" for the ceremony, include copies of orders, award citations, retirement certificates, and spouse LOAs as required.	

Figure 3-5.--Ceremonial Checklist.

DATE	SECTION	ACTION REQUIRED	REMARKS
C-30	G/S-4	Request tentage, seating and other requirements identified in the Bulletin/LOI.	
C-30	G/S-4	Request "Quiet Hours" from civilian contractors.	
C-20	G/S-3	Ensure final coordination has been made with all units to deconflict scheduling problems.	
C-15	G/S-1	Coordinate with chaplain's office to identify who will provide invocation for ceremony.	
C-15	Cmdrs	Provide G/S-3 with a by name list of key personnel.	
C-15	G/S-1	Deliver program to Defense Printing Service.	
C-15	G/S-3	Pick up copy of rehearsal tape with ceremony music from band.	
C-15	G/S-1	Request PAO coverage, provide copy of "Narration" to PAO.	
C-15	G/S-3	Coordinate traffic and force protection measures with military police.	
C-15	G/S-1	Identify if a reception is being held.	
C-14	G/S-4	Request mowing of parade field and surrounding areas.	

Figure 3-5.--Ceremonial Checklist--Continued.

DATE	SECTION	ACTION REQUIRED	REMARKS
C-14	G/S-4	Develop parking plan and coordinate with G/S-3.	
C-10	G/S-6	Provide a public address system for the rehearsals and ceremony, to include rehearsal music.	
TBD	G/S-3	Brief CG/CO on conduct of the ceremony.	
C-10	G/S-1	Provide a copy of the "Narration" to the narrator.	
C-10	G/S-3	Ensure parade field is marked, coordinate with SgtMaj.	
C-10	Supply	Complete issue of parade gear, i.e., swords, frogs, belts as required.	
C-10	G/S-4	Coordinate with Armory and Cmdrs for drawing weapons for the ceremony and final rehearsal.	
C-7	G/S-1	Begin preparation of VIP seating chart.	
C-7 to C-1	G/S-3 SgtMaj	Conduct key personnel rehearsal.	
C-5	G/S-1	Ensure completion and pick up program from the Defense Printing Service.	
C-3	G/S-4	Set up tents, chairs, and bleachers.	
C-3	Designated Units	Provide escorts and ushers.	
C-3	G/S-1	Coordinate purchase and delivery of flowers by COs, SgtsMaj, or retiree.	

Figure 3-5.--Ceremonial Checklist--Continued.

DATE	SECTION	ACTION REQUIRED	REMARKS
TBD	Arty	Coordinate with SgtMaj for final placement of saluting battery.	
C-1	G/S-3 SgtMaj	Conduct an all hands rehearsal without band.	
C-1	G/S-3 SgtMaj	Conduct an inclement weather with key personnel if required.	
C-1	G/S-4	Ensure completion of mowing, trimming, police of area, and conduct an inspection.	
C-1	G/S-3 G/S-4	Rehearse traffic control plan with road guard detail and VIP parking escorts.	
C-1	G/S-1	Coordinate last minute changes to the seating chart.	
C-1	G/S-4	Make final coordination with civilian contractors for "Quiet Hours."	
C-Day	G/S-4	Wipe down bleachers, setup cold water dispensers w/cups behind each seating area, and check police of area. Ensure parking lots are marked.	
C-Day	G/S-1	Take delivery of flowers for spouses.	
C-Day	G/S-4	Post traffic signs at designated intersections and road guards at appropriate time.	
C-Day	G/S-3	Ensure corpsman and ambulance are in place.	
C-Day	G/S-1	Label VIP seating area and brief ushers on duties to include those designated to deliver flowers, and tasked with VIP parking duties.	

Figure 3-5.--Ceremonial Checklist--Continued.

DATE	SECTION	ACTION REQUIRED	REMARKS
C-Day	G/S-3	Make final decision on implementing weather plan. Make frost calls as required if implemented.	
C-Day	G/S-1	Have Marine designated for break-out briefed and standing by.	
C-Day	G/S-4	Ensure windows and shades in the buildings around the ceremony area are closed.	
H-30	Band	Pre-ceremony concert begins.	
H-15	COT/Staff	In position near the reviewing area.	
H-Hour	CG/CO	Ceremony begins.	

Figure 3-5.--Ceremonial Checklist--Continued.

12. Seating Guidance

a. The number of seats per row and the number of rows is determined by where the ceremony is held (inside or outside) and the size of the location. The outgoing Commanding Officer (CO) will sit in the first chair, on right side of the aisle, with their spouse seated next to them. The RO would be seated next to the outgoing CO's spouse. The incoming CO will sit in the first chair, on the left side of the aisle, with their spouse seated next to them. Seating for the official party should be in keeping with official precedence following the customary alternating pattern of first senior officer to RO's right or the right of the RO's spouse.

b. The next senior officer present sits to the left of the incoming CO or CO's spouse. (An exception to this would be for a regiment or battalion having a ceremony; it is appropriate to seat the Division Commanding General (CG) next to the outgoing CO and then the most senior officer (who may outrank the Division CG) next to the incoming CO, and then continue alternating right to left. This also applies to the Assistant Division Commander. He/she may not be the senior colonel, but by virtue of his/her billet, he/she would be the first colonel seated after all the General Officers. Continue alternating right to left according to the officer's rank with their spouse beside them. Retired officers are seated according to their rank after active and reserve officers (i.e., seat all active duty Major Generals attending, then all reserve Major Generals, and then if you have a retired Major General, they would be seated after the last reserve Major General, but before the first active duty Brigadier General).

Chapter 4

Reviews

TABLE OF CONTENTS

<u>IDENTIFICATION</u>	<u>TITLE</u>	<u>PAGE</u>
1.	General.....	4-2
2.	Elements of a Review.....	4-2
3.	Differences Between a Parade and a Review.....	4-2
4.	Command of Troops.....	4-2
5.	Preparations.....	4-2
6.	Formations.....	4-3
7.	Forming the Review.....	4-3
8.	Reviewing Party.....	4-5
9.	Sequence of Events for a Review.....	4-5
Figure 4-1	Troop Formations.....	4-3
Figure 4-2	Reviewing Party.....	4-5
Figure 4-3	Formation on the Line of Troops and Band Movement.	4-7
Figure 4-4	Adjutant Takes Post.....	4-8
Figure 4-5	Adjutant, Commander of Troops and Staff Move to Center of Field.....	4-9
Figure 4-6	Route of March for the Inspecting Party.....	4-13

Chapter 4

Reviews

1. General. Reviews, when practicable, are held on the following occasions:

- a. The presentation of United States or foreign decorations.
- b. The decoration of organizational colors.

c. The retirement of an individual or group of any rank. Local commanders should consider it appropriate, when only one distinguished individual is retiring, to allow that individual to participate as the reviewing officer.

2. Elements of a Review. A review consists of four parts:

- a. Formation of troops.
- b. Presentation of the command to the reviewing official. This includes an inspection of the troop formation (trooping the line).
- c. Presentation of decorations and retirements.
- d. March in review.

3. Differences Between a Parade and Review

a. The sequence of events for a parade contains the following elements that a review does not contain:

- (1) March on of troops (optional for a review).
- (2) "Sound Off."
- (3) Manual of arms.
- (4) Receive the report.
- (5) Officers center.

b. The sequence of events for a review contains an inspection (trooping the line) and a parade does not.

4. Command of Troops. The senior officer taking part in a ceremony is designated as the commander of troops. The commander of troops is responsible for the formation, presentation, and march in review. When a commander reviews the troops, the commander designates another officer as commander of troops. When the review is given for an important visitor or senior commander, the local commander designates another officer as commander of troops so the local commander may accompany the visitor or senior officer during the review.

5. Preparations. The line on which troops are to form and along which they are to march is marked out or otherwise designated by the sergeant major or senior enlisted of the unit. The post of the reviewing officer, opposite the center of the line of troops, is marked on each flank with a dress

guidon. Enclosure 2, Chapter 3 shows examples of the minimum marking for parades and reviews.

6. Formations

a. The troops may be formed prior to the start of a review or marched on at the beginning of the review. Troops form in line for a review. Battalions and regiments may form in line with companies in line or with companies in mass formation. (See enclosure 1, chapters 11 and 12.) When space is limited, for reviews conducted by regiments and larger organizations, the formation may be in line with battalions and independent companies in mass formation. Such formations may be modified when necessary because of space available or other exceptional circumstances. The initial formation will also influence the formation in which troops are to march in review. (See figure 4-1.)

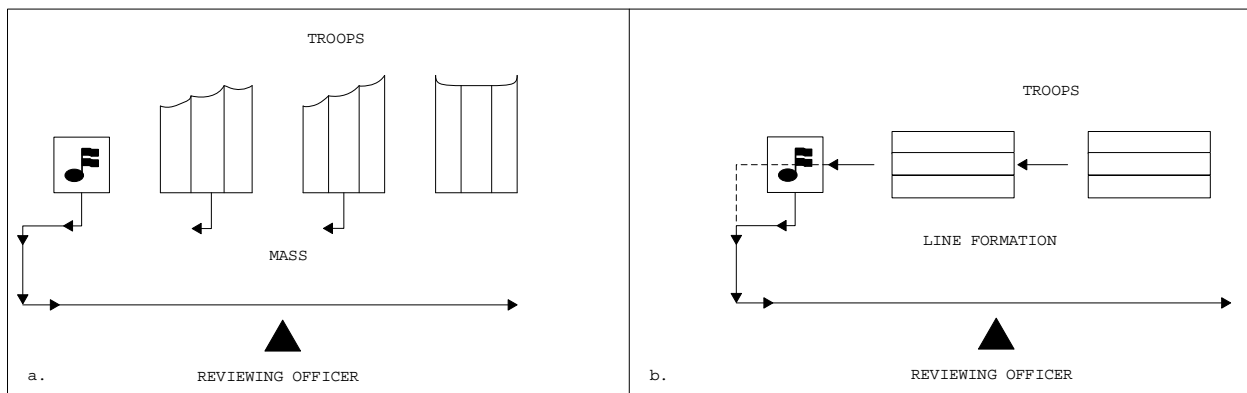

Figure 4-1.--Troop Formations.

b. In reviews involving two or more arms or types of organizations, troops are arranged as directed by the commander of troops. The following order, from right to left in line, may be used as a guide: infantry units, artillery, tanks, and motorized or service units. The provisions of enclosure 2, chapter 3, paragraph 2 also apply in reviews consisting of units from different services of the United States or foreign nations.

c. Arrangements should be made to provide for forming normal march columns after passing in review. An area should be designated where this can be accomplished without blocking the line of march of units that have not yet passed in review. Unless otherwise directed by the commander of troops, after passing in review, units revert to the control of their respective commanders.

7. Forming for the Review

a. Forming for a Battalion or Regimental Review. Initial forming for a review for a battalion or regiment with a march on is conducted per provisions of enclosure 1, chapters 11 and 12.

(1) If the unit is marched on at the beginning of the review, the sequence of events is the same as for a parade up to and including the adjutant's command of guides post. The next step in the sequence would be for the adjutant to present the command to the commander of troops. The sequence would continue as in paragraph 9.a. of this chapter.

(2) If the unit is formed prior to the start of a review, use the sequence of events in paragraph 9.b. of this chapter.

(3) Prior to presenting the command to the commander of troops, the colors may be trooped as described in enclosure 1, chapter 7, section 3, paragraph 7.

(4) If not at an evening review including "Retreat," after the command has been presented to the commander of troops and the staff boxed, the reviewing officer will assume the designated position.

(5) If at an evening review including "Retreat," after the command has been presented to the commander of troops and returned to order arms, the staff is not boxed. Instead, the commander of troops commands "**Present, ARMS,**" then when all troops are at present arms, commands "**SOUND RETREAT**" (or gives a prearranged signal to the band) at the time prescribed for evening colors. The band plays "Retreat" and then the "National Anthem" immediately afterwards. The flag is lowered during the "National Anthem" as prescribed in enclosure 1, chapter 7, paragraph 4. The commander of troops and the staff face the formation throughout this portion of the sequence. After the last note of the "National Anthem," the commander of troops and staff terminate their salutes and the commander of troops commands "**Order, ARMS.**" The staff is then boxed and the review continues as outlined in paragraph 9 of this chapter.

Note: To conduct retreat as part of an evening review, troops must be formed in sufficient time prior to sunset to permit the command to be presented and evening colors to be conducted at the proper time.

b. Forming for Large Reviews

(1) For reviews conducted by organizations larger than a regiment, such as a division, the same basic commands, procedures, and sequence of events prescribed above for a battalion or regimental review apply.

(2) Normally, in large reviews, battalions and independent companies are in mass formation. Troop units take their positions on the line of troops prior to the third "Adjutant's Call" being sounded to form for the review. In this regard, at the second "Adjutant's Call," regiments may be formed, presented to their commanders, and reports received at their designated locations, or the second "Adjutant's Call" may be conducted so that the regiments are formed at their positions on the line of troops for the review. Regardless, in large reviews, the commander of troops should prescribe the routes of march and arrival and departure times. If the frontage of the unit has been measured and marked, they may arrive independently in any convenient order to occupy their places on line. If this is not done, units must form in succession from the right. Because of the time consumption involved in the latter method, the former is preferred.

(3) The commander of troops and adjutant of reviews conducted by organizations larger than a regiment give commands in the same manner as prescribed for a regiment in enclosure , chapter 12, (i.e., in a manner which does not require execution by the troops). In formations consisting of two or more regiments, the regimental commander repeats those commands requiring execution by the troops. Within each regiment, battalions and independent companies execute

movements on the command of execution of their respective commanders. Independent battalions not part of a regiment, execute movements on the command of their respective commanders. Movements are executed successively by units from right to left.

8. Reviewing Party

a. After the staff has been boxed and the commander of troops has faced the reviewing area (see paragraph 9.c.(11) of this chapter), the reviewing officer, with the staff (if applicable), moves into position to receive the review.

b. The local commander, distinguished civilians, and the officer and enlisted staff take positions at their posts (see figure 4-2) facing the troops. The officer, who is senior, with the staff, will take position on the right.

c. An officer from the local commander's staff is designated to escort distinguished civilians to their positions. If a civilian is to receive the review, the civilian takes position on the right of the local commander. If necessary, the civilian is given an explanation of the ceremony by an escort or the local commander.

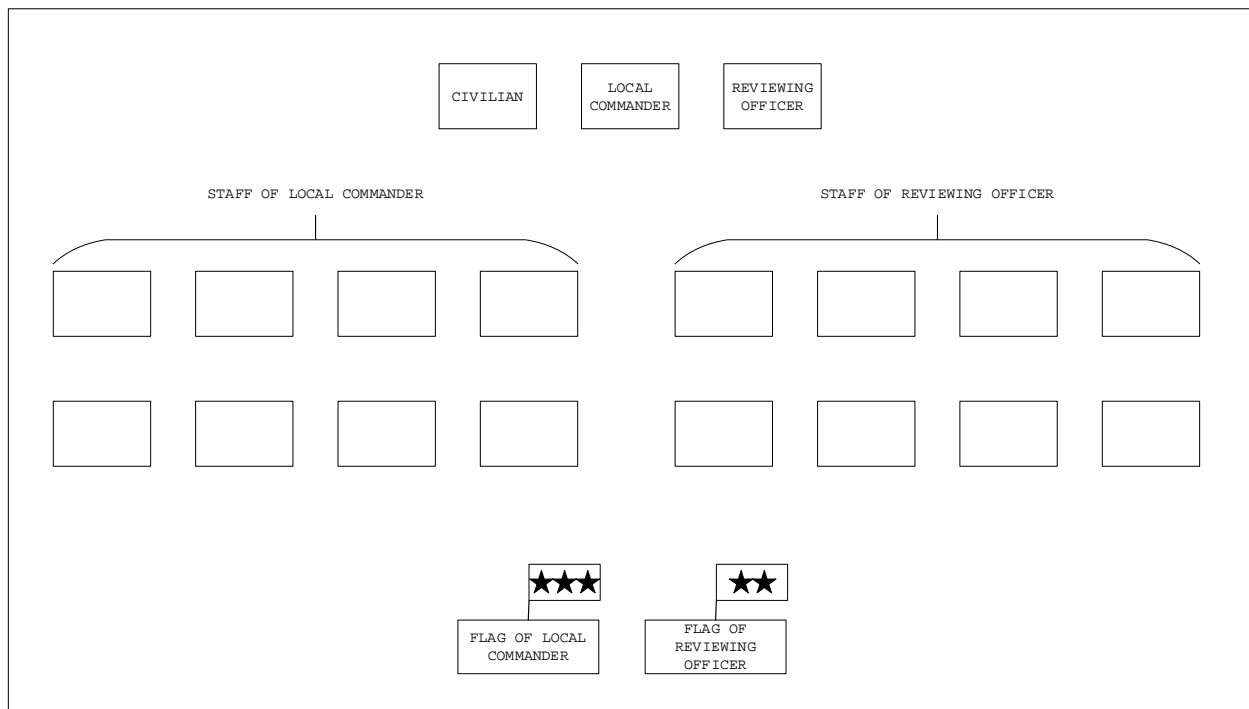

Figure 4-2.--Reviewing Party.

9. Sequence of Events for a Review

a. March on for a Review. The organization is formed in the staging area. Troops are at parade rest; officers and noncommissioned officers have swords drawn, if so armed.

(1) The organizational/review staff is in position near the reviewing

stand.

(2) For regimental reviews, battalion adjutants take their position behind the line of troops, swords drawn and at parade rest.

(3) At H Hour-15, the narrator introduces the band. The band begins pre-review concert.

NARRATOR: "LADIES AND GENTLEMEN, TODAY'S MUSIC IS PROVIDED BY THE _____ BAND UNDER THE DIRECTION OF _____ . THE DRUM MAJOR IS _____."

(4) At H Hour-5, the band moves to its position on the right of line, countermarches and halts as shown in enclosure 2, chapter 5, figure 5-1.

(5) The commander of troops forms the staff per enclosure 2, chapter 2.

(6) At H-Hour, the narrator makes opening remarks.

NARRATOR: "GOOD MORNING (AFTERNOON/EVENING), LADIES AND GENTLEMEN. ON BEHALF OF THE COMMANDING OFFICER (GENERAL), _____, WELCOME TO THE _____ CEREMONY. TODAY'S REVIEW IS BEING EXECUTED BY THE OFFICERS AND MARINES OF _____."

(Optional) "LADIES AND GENTLEMEN, PLEASE RISE FOR THE INVOCATION BY COMMAND CHAPLAIN _____, CHAPLAIN CORPS, UNITED STATES NAVY."

(7) Invocation is given.

Note: After the invocation: **"LADIES AND GENTLEMEN, PLEASE BE SEATED."**

(8) Commander of troops commands **"TAKE YOUR POST."**

(9) The adjutant moves by the most direct route to position on the line of troops. (See enclosure 2, chapter 5, figure 5-2.)

Note: At this time, depending on the formation, the command may choose to have the narrator read verbiage similar to the following:

NARRATOR: (AS THE ADJUTANT MOVES INTO POSITION) "PRESENT DAY REVIEWS IN THE MARINE CORPS HAVE THEIR BASIS IN BOTH HISTORY AND TRADITION, THE MASSED FORMATION OF TROOPS ON ONE LONG LINE AT CLOSE INTERVAL, MADE POSSIBLE THE MASSING OF FIREPOWER FROM MUZZLE LOADED MUSKETS OF THE PAST. THE ADJUTANT FORMS THE LINE OF BATTLE, AND IN THOSE EARLY DAYS, THAT LINE CONSISTED OF TWO OR THREE RANKS, MUCH LIKE IN THE REVIEW YOU WILL SEE TODAY."

(10) At this point, follow the procedures to form a battalion

for march on see enclosure 1, chapter 11 and to form a regiment see enclosure 1, chapter 12.

(11) After the unit is formed, the guides post. The procedures for a review in paragraph 9.c. of this chapter are followed.

b. Units Formed on the Line of Troops Prior to the Start of the Review. The battalion is formed on the line of troops. Alignment is obtained and the unit is placed at parade rest. (See figure 4-3.)

(1) At H Hour-15, the battalion staff is in position near the reviewing stand. The narrator introduces the band. The band begins pre-review concert.

(2) At H Hour-5, the band moves to its position 12 paces to the right of the extreme right unit on the line of troops. (See figure 4-3.)

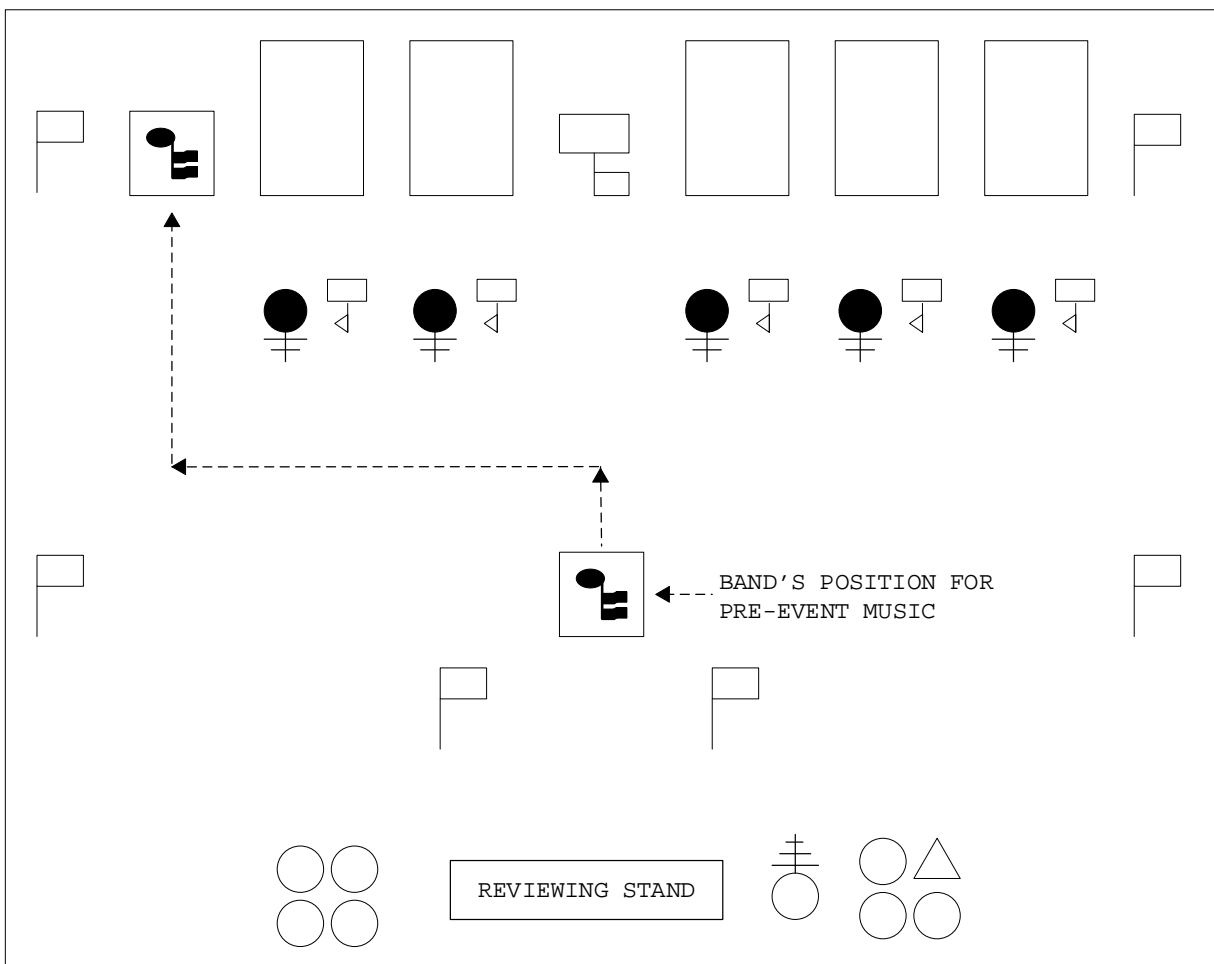

Figure 4-3.--Formation on the Line of Troops and Band Movement.

(3) The commander of troops moves to a position centered between the dress guidons, halts, faces the reviewing stands and commands "**Staff, FALL IN.**" The staff moves smartly to their positions. (See figure 4-3.) Once the staff is in position, the commander of troops faces about towards the line of troops.

NARRATOR: "GOOD MORNING (AFTERNOON/EVENING), LADIES AND GENTLEMEN. ON BEHALF OF THE COMMANDING OFFICER (GENERAL), _____, WELCOME TO THE _____ CEREMONY. TODAY'S REVIEW IS BEING EXECUTED BY THE OFFICERS AND MARINES OF _____."

(Optional) "LADIES AND GENTLEMEN, PLEASE RISE FOR THE INVOCATION BY COMMAND CHAPLAIN _____, CHAPLAIN CORPS, UNITED STATES NAVY."

(4) Invocation is given.

Note: After the invocation: "LADIES AND GENTLEMEN, PLEASE BE SEATED."

(5) Commander of troops commands "**TAKE YOUR POST.**"

(6) The adjutant moves by the most direct route to position on the line of troops. Once in position, the adjutant faces down the line of troops, draws sword and commands. (See figure 4-4.)

NARRATOR: (AS THE ADJUTANT MOVES INTO POSITION) "PRESENT DAY REVIEWS IN THE MARINE CORPS HAVE THEIR BASIS IN BOTH HISTORY AND TRADITION, THE MASSES FORMATION OF TROOPS ON ONE LONG LINE AT CLOSE INTERVAL, MADE POSSIBLE THE MASSING OF FIREPOWER FROM MUZZLE LOADED MUSKETS OF THE PAST. THE ADJUTANT FORMS THE LINE OF BATTLE, AND IN THOSE EARLY DAYS, THAT LINE CONSISTED OF TWO OR THREE RANKS, MUCH LIKE IN THE REVIEW YOU WILL SEE TODAY."

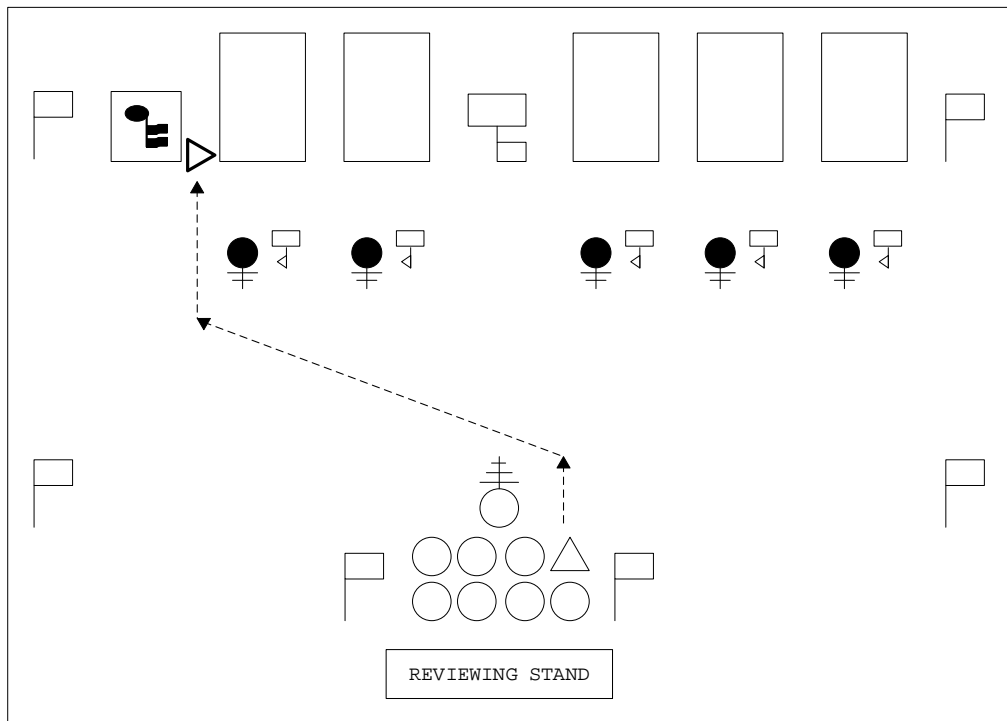

Figure 4-4.--Adjutant Takes Post.

(7) Adjutant commands "**SOUND ATTENTION.**"

(8) The company commanders execute attention, face their companies and in sequence command.

(9) Company commander commands "**Company, ATTENTION.**"

(10) The companies execute the commands. When all companies are at attention, the adjutant commands.

(11) Adjutant commands "**SOUND ADJUTANT'S CALL.**"

(12) On the first beat of the music after "*Adjutant's Call*," the commander of troops and staff march to their position on the parade field and halt facing the line of troops. (See figure 4-5.) Once the units have been formed on the line of troops and the command "**Guides, POST,**" has been given (see enclosure 1, chapter 11), the adjutant moves to a position three paces and centered on the commander of troops and facing the line of troops.

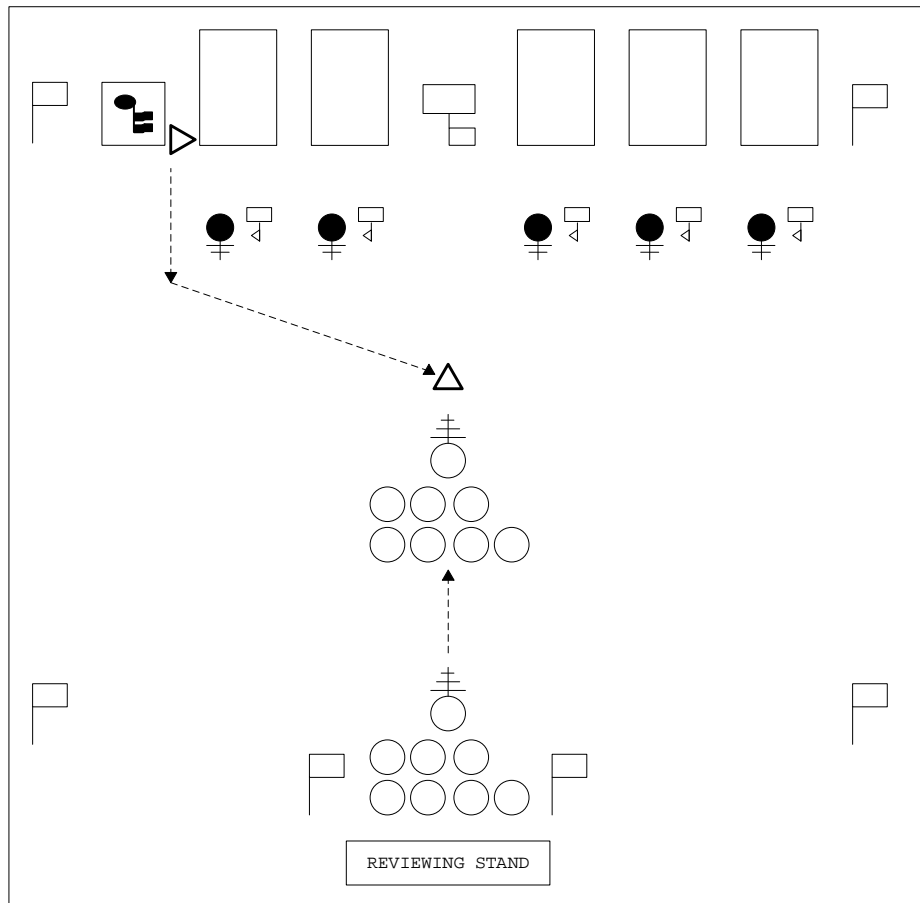

Figure 4-5.--Adjutant, Commander of Troops and Staff Move to Center of Field.

Note: The sequence of events is continued in paragraph 9.c. of this chapter. It is at this point in time that the sequence of events, whether the troops are pre-staged or marched on is the same.

c. Presentation and Honors

(1) Adjutant commands **"Present, ARMS."**

(2) Battalion executes. The color guard riflemen execute present arms, however, the organizational colors does not present to the commander of troops. The adjutant then faces the commander of troops, presents sword and reports;

(3) Adjutant commands **"SIR/MA'AM THE REVIEW IS FORMED."**

(4) The commander of troops returns the adjutant's salute and directs the adjutant.

(5) Commander of troops commands **"TAKE YOUR POST SIR."**

(6) The adjutant executes carry sword, moves to position in the staff, halts, faces the line of troops and goes to order sword. Once the adjutant has halted, the commander of troops commands **"Staff, Draw, SWORD"** and **"Staff, Order, SWORD."**

(7) The commander of troops then commands the battalion to **"Order, ARMS."**

(8) The battalion executes. The color guard executes **"Order, COLORS."**

(9) Commander of troops commands **"BOX THE STAFF."**

(10) The adjutant moves the staff to its new position using the following commands: **"Staff, Carry, SWORD;" "Staff, Left, FACE;" "Column Right, MARCH;" "Staff, HALT;" "Staff, Right, FACE;"** and **"Staff, Order, SWORD."**

(11) After the staff is in position, the unit commander and/or reviewing officer takes position in the reviewing area. The commander of troops then commands **"Present, ARMS."**

(12) The battalion executes. The color guard riflemen execute **"Present, ARMS."** The organizational color bearer presents colors when and if appropriate. The commander of troops then faces the reviewing area and commands **"Staff, Present, SWORD."**

(13) Staff and commander of troops execute. Musical honors and/or gun salutes are fired if appropriate. The unit commander and/or reviewing officer return the salute. After the last note of musical honors, or the final gun salute, the commander of troops commands **"Staff, Order, SWORD."**

(14) Staff executes. Commander of troops returns to the carry. The commander of troops then faces the line of troops and commands **"Order, ARMS."**

(15) The color guard executes **"Order, COLORS."**

d. Inspection

(1) Battalion and colors execute. The commander of troops then commands **"Parade, REST."**

(2) Battalion and colors execute. The band remains at attention. The commander of troops then faces the reviewing area and goes to order sword. The unit commander and/or reviewing officer (inspecting party) then move forward to the commander of troops.

(3) The commander of troops presents sword and reports **"SIR/MA'AM, THE BATTALION IS FORMED FOR INSPECTION."**

(4) The unit commander and/or reviewing officer returns the salute. The commander of troops terminates the salute and then executes return sword.

(5) The inspecting party and commander of troops step off towards the extreme right flank (normally the band) of the formation. They march as one rank with the senior member of the inspecting party on the right and the commander of troops on the left.

(6) If the inspection is to be made in vehicles, the reviewing party embarks at the post of the reviewing officer. The reviewing officer enters first and occupies the left rear position. The unit commander occupies the right rear position. The vehicle then moves to the commander of troops position, approaching from the left and stops. The commander of troops then salutes, reports, returns sword, and enters the vehicle in the right front position. The adjutant would then command the staff, **"Staff, Parade, REST."** (Figure 4-6 shows the route of march for the inspecting party.)

(7) Band plays martial music during the inspection.

(8) When the inspecting party reaches the right flank of the formation they change order of precedence from left to right (reviewing officer, unit commander, commander of troops).

(9) The inspecting party marches down the line of company commanders.

Note: If the formation is a company line formation, the inspecting party would march down the line of platoon commanders.

(10) As the inspecting party approaches the left flank of the company, the company commander goes to carry sword, faces the company and commands **"Company, ATTENTION."**

(11) Company executes. The company commander then commands **"Eyes, RIGHT."**

(12) Company executes. The company commander then faces front and quietly commands the guide to **"Eyes, RIGHT."** The company commander presents sword, the guide presents guidon and both execute eyes right. Except for the commander, other officers and noncommissioned officers in the formation who are armed with swords remain at the order during eyes right.

(a) As the inspecting party moves across the member's front, each Marine turns their head and eyes to the left, following the inspecting party, until their head and eyes are to the front. Each Marine then stops the movement of their head and eyes and remains at attention.

(b) After the inspecting party has cleared the left flank of

the company, the company commander quietly gives the command of **"Order, ARMS"** to the guide.

(c) The company commander then executes carry sword, faces the company and commands **"Parade, REST."**

(13) Company executes. Guide and company commander execute. The company commander remains facing the company.

(a) This process is repeated by each subsequent company commander.

(b) The inspecting party continues to move down the line of company commanders, saluting each company commander as they pass.

(c) The inspecting party salutes the colors as they pass in front of (but not behind) the colors. The color guard executes eyes right (halted) on the command by the color sergeant. All members of the color guard except the national color bearer smartly turn their head and look 45 degrees to the right.

(d) After passing the left flank of the formation, the inspecting party turns left and marches behind the formation. The last company commander does not give the command of parade rest until the inspecting party has passed behind his/her company.

(14) As the inspecting party approaches the rear of each company, the company commander commands **"Company, ATTENTION."**

(15) The company executes. Once the inspecting party has cleared the company's rear, the company commander commands **"Parade, REST."**

(16) The company executes. The company commander then faces the reviewing area and goes to order sword and parade rest. This process is repeated by each subsequent company commander.

(17) After the inspecting party completes passing around the rear of the formation, the commander of troops moves to a position three paces in front of and one pace to the right of the band, draws sword and waits for the inspecting party to critique the inspection.

(18) When the commander of troops is in position, the reviewing officer and/or unit commander moves to a position three paces in front of and facing the commander of troops. The reviewing officer and/or unit commander and commander of troops exchange salutes.

(19) The reviewing officer and/or unit commander then moves back to their position in the reviewing area. The commander of troops returns to a position in front of the staff.

(20) The adjutant, seeing the commander of troops returning to position calls the staff to attention.

(21) When the commander of troops arrives at the position in front of the staff, he halts and faces the line of troops, waits for the band to stop playing and commands **"Battalion, ATTENTION."**

(22) Band stops playing.

(23) The battalion executes.

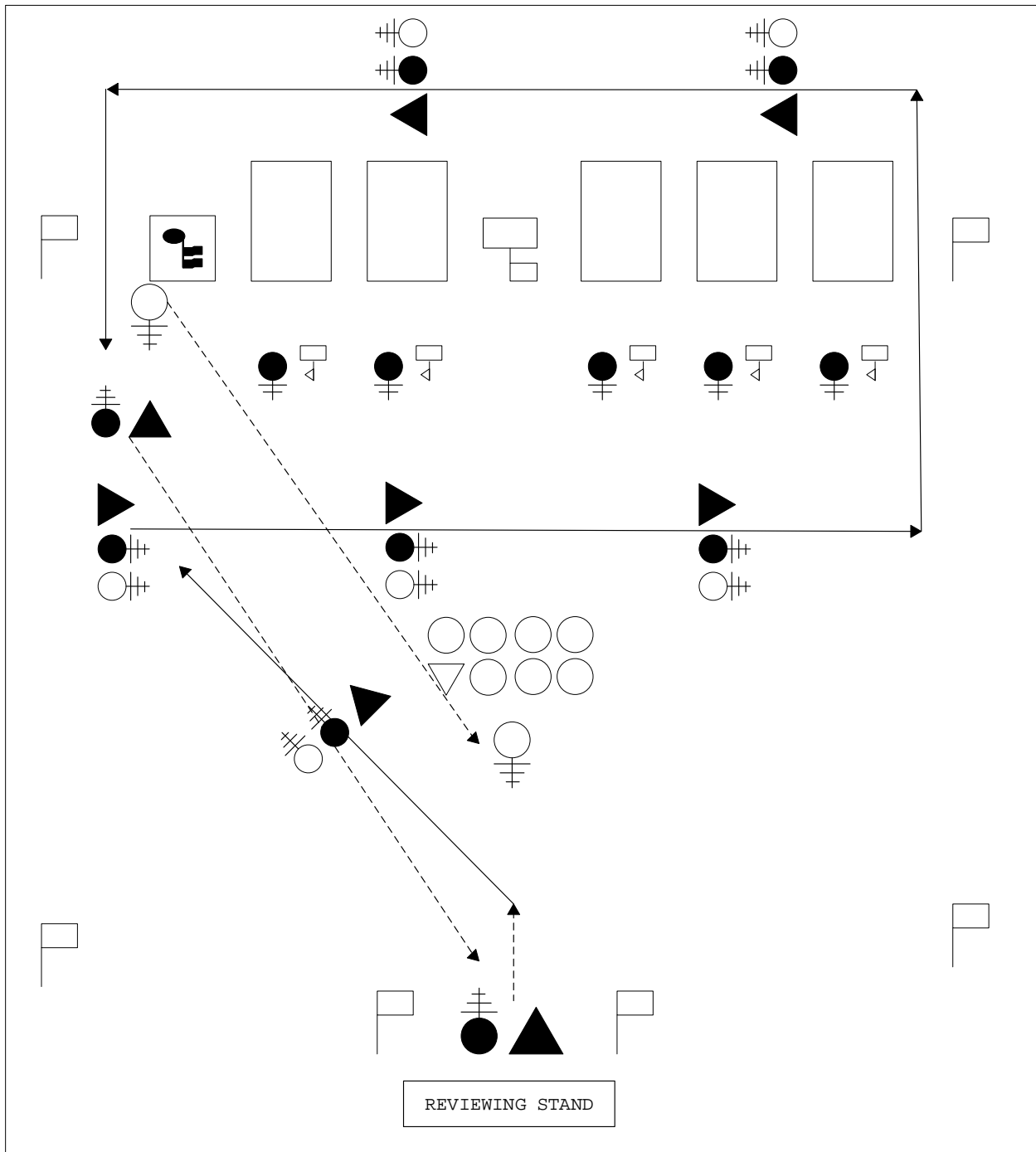

Figure 4-6.--Route of March for the Inspecting Party.

(24) Note. At this time if:

(a) The review is being held as an awards/retirement ceremony, go to enclosure 2, chapter 6 and follow the sequence of events specified for the presentation of awards/ retirement.

(b) The review is being held for a change of command ceremony go to enclosure 2, chapter 9 and follow the sequence of events specified for a change of command.

(c) The review is being held for a relief and appointment of the sergeants major go to enclosure 2, chapter 10 and follow the sequence of events specified for the relief and appointment of the sergeant major.

(d) The review is being held for an activation or deactivation go to enclosure 2, chapter 11 and follow the sequence of events specified for the activation or deactivation of a unit.

(e) After completing one of the above sequences of events, return to this chapter and continue as follows.

e. March in Review

(1) Unit commander/reviewing officer commands "**MARCH THE COMMAND IN REVIEW.**"

(2) The commander of troops faces the line of troops and commands "**PASS IN REVIEW.**"

(3) The unit marches in review as described in enclosure 2, chapter 5, paragraphs 8, 9, 10, and 11. After the last element has marched in review, and the band and parade staff have cleared the field the narrator has announced the conclusion of the parade.

<p>NARRATOR: "LADIES AND GENTLEMEN, THIS CONCLUDES TODAY'S REVIEW. ON BEHALF OF THE COMMANDING OFFICER (GENERAL) AND THE OFFICERS AND MARINES OF _____, THANK YOU FOR YOUR ATTENDANCE. SEMPER FIDELIS."</p>
--

Chapter 5

Parades

TABLE OF CONTENTS

<u>IDENTIFICATION</u>	<u>TITLE</u>	<u>PAGE</u>
1.	General.....	5-2
2.	Formations.....	5-2
3.	Commander of Troops.....	5-3
4.	Preparation.....	5-3
5.	Sequence of Events, Pre-parade Serenade through the Adjutant.....	5-3
6.	Sequence of Events for Forming a Battalion and Larger Units.....	5-6
7.	Sequence of Events for Presentation of the Command.....	5-8
8.	Sequence of Events to March in Review in Column from a Battalion Line, Company Line Formation.....	5-16
9.	Sequence of Events to March in Review in Column from a Battalion Line, Company Mass Formation.....	5-19
10.	Sequence of Events to March in Review in Battalion Column, Company Mass Formation.....	5-22
11.	to March in Review, Companies in a Column of Platoons in Line.....	5-24
12.	Regimental Parades.....	5-25
13.	Battalion and Regimental Formations.....	5-29
14.	Street Parades.....	5-30
Figure 5-1	Movement of the Band.....	5-4
Figure 5-2	Adjutant Moves to Post.....	5-6
Figure 5-3	Sound Off.....	5-8
Figure 5-4	Officers Center.....	5-10
Figure 5-5	Post March.....	5-13
Figure 5-6	Right Face.....	5-17
Figure 5-7	March in Review, Companies in Column.....	5-18
Figure 5-8	Column of Threes, From the Right.....	5-21
Figure 5-9	March in Review, Companies in Mass.....	5-23
Figure 5-10	Marching in Review, Companies in Column of Platoons on Line.....	5-25
Figure 5-11	Regimental Officers Center.....	5-27
Figure 5-12	Regimental March in Review.....	5-28

Chapter 5

Parades

1. General. The appearance and movement of troops in formation are the primary considerations of a ceremonial parade. The preparation, organization of troops, and the conduct of a ceremonial parade require familiarity with those chapters for platoon, company, battalion, and regimental drill as well as organizational and parade staff. Normally, a parade consists of the following elements:

- a. Pre-parade serenade by the band.
 - b. Forming the staff, and posting the adjutant.
 - c. March on and formation of the command (forming without a march on is optional).
 - d. Trooping the colors if appropriate for the type of ceremony.
 - e. "Sound Off" and trooping the line by the band.
 - f. The manual of arms.
 - g. Receiving reports and publishing orders by the adjutant.
 - h. Officers center.
 - i. Presentation of the command and honors to the reviewing officer.
 - j. Presentation of awards, promotions, retirements, changes of command, relief and appointment of the sergeant major, etc.
 - k. March in review.
1. Additionally, bayonets may be fixed, if desired, and, at evening parade, retreat may be included as part of the ceremony.

2. Formations

a. The battalion is formed per the procedures prescribed in enclosure 1, chapter 11 and the regiment is formed per the procedures in enclosure 1, chapter 12. The unit commander designates the formation for the parade.

b. The basic formations a commander may choose for battalion parades are:

(1) Battalion line, company line. Used when space is available or when a larger front is desired for the line of troops.

(2) Battalion line, company mass (extended mass). Used when the space available for the "front" for the line of troops is limited.

c. The basic formations a commander may choose for regimental parades are:

(1) Regiment in line, battalions in line with companies in line or mass (extended mass) formation.

(2) Regiment in line, battalions in mass (extended mass).

3. Commander of Troops. The senior officer taking part in a ceremony is designated as the commander of troops. The commander of troops is responsible for the formation, presentation, and march in review. When a commander acts as the reviewing officer for the parade, the commander designates another officer as commander of troops.

4. Preparation. The line on which troops are to form and along which they are to march is marked out or otherwise designated by the sergeant major or senior enlisted of the unit. The post of the reviewing officer, opposite the center of the line of troops, is marked on each flank with a dress guidon. Additionally, commander's posts, unit guide's posts, and turning points for approaching the line of troops may also be marked. Enclosure 2, Chapter 3, paragraph 8 of this Manual provides details for marking a parade field.

5. Sequence of Events, Pre-Parade Serenade through the Adjutant Taking Post

a. The sequence of events in this paragraph is the same for all parades, regardless of the size of the units participating. Experience has proven, this is the best way to keep the commander of troops, adjutant, narrator, etc., synchronized for the parade.

(1) H-Hour-15 Minutes

(a) The organization is formed in the assembly area. Troops are at parade rest; officers and noncommissioned officers have swords drawn, if so armed. There will be occasions when it will be desired or necessary to form the unit without a march on. In this case, the battalion is formed at H-15 on the line of troops, alignment is obtained, and the unit is placed at parade rest at which time the sequence continues as outlined in this Chapter.

(b) The organizational/parade staff is in position near the reviewing stand.

(c) For regimental parades, battalion adjutants take their position behind the line of troops, swords drawn and at parade rest.

(d) Narrator introduces the band. The band begins pre-parade serenade.

NARRATOR: "LADIES AND GENTLEMEN, THE MUSIC FOR TODAY'S PRE-PARADE SERENADE IS PROVIDED BY THE MARINE CORPS BAND (POST/BASE) _____ UNDER THE DIRECTION OF THE DRUM MAJOR IS _____."

(2) H-Hour-5 Minutes

(a) The band moves to its position on the right of line, countermarches and halts. (See figure 5-1.)

(b) The commander of troops forms the staff per enclosure 2, chapter 2.

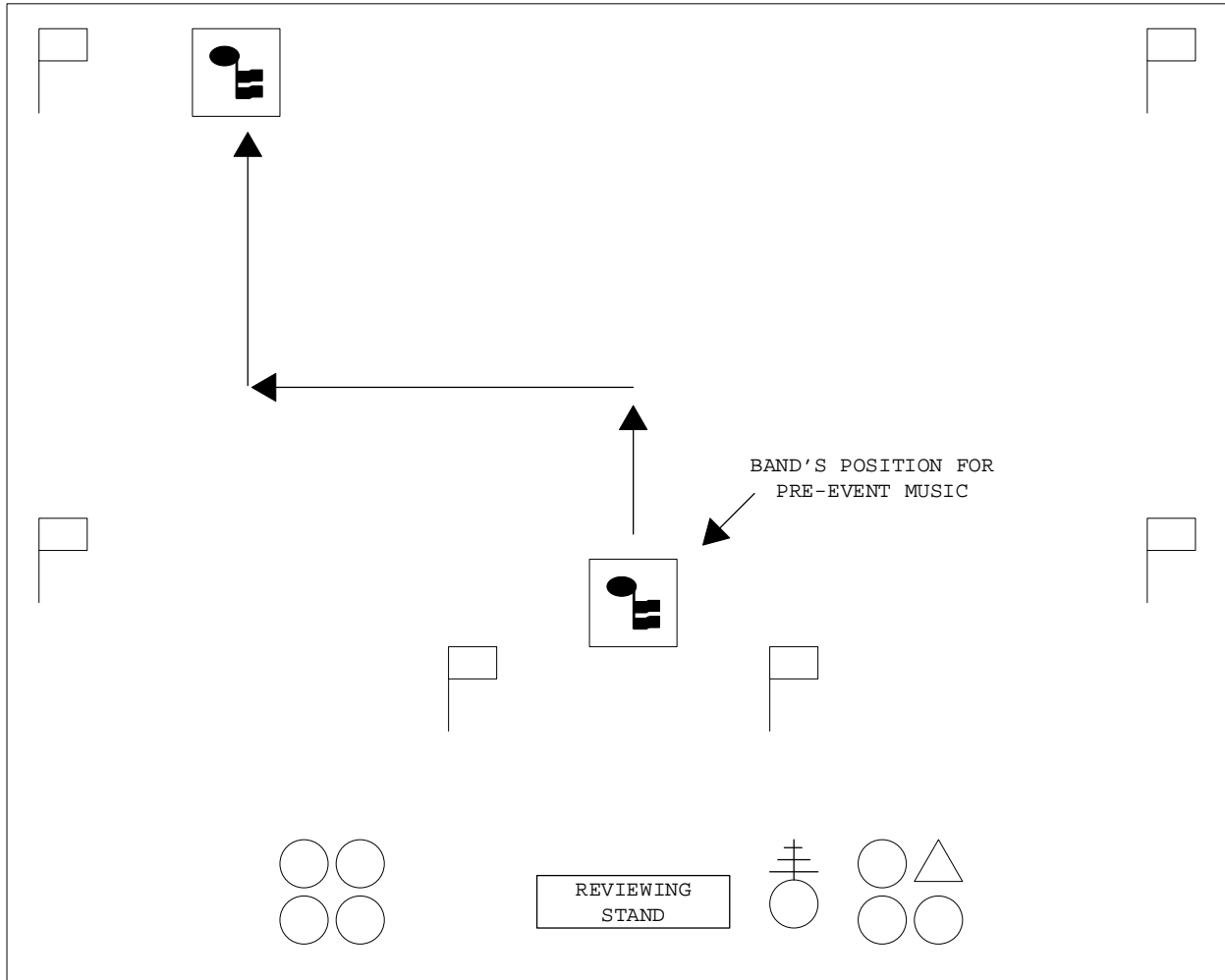

Figure 5-1.--Movement of the Band.

(3) H-Hour

(a) Narrator makes opening remarks.

NARRATOR: "GOOD MORNING (EVENING), LADIES AND GENTLEMEN. ON BEHALF OF THE COMMANDING OFFICER (GENERAL), _____, WELCOME TO THE _____ CEREMONY. TODAY'S PARADE IS BEING EXECUTED BY THE OFFICERS AND MARINES OF _____."

(Optional) "LADIES AND GENTLEMEN, PLEASE RISE FOR THE INVOCATION BY COMMAND CHAPLAIN _____, CHAPLAIN CORPS, UNITED STATES NAVY."

(b) Invocation is given.

(Note: After the invocation) "LADIES AND GENTLEMEN, PLEASE BE SEATED."

(c) Commander of troops commands "TAKE YOUR POST."

(d) The adjutant moves by the most direct route to a position on the line of march. (See figure 5-2.)

NOTE: At this time, depending on the formation, the command may choose to have the narrator read verbiage similar to the following:

NARRATOR: (AS THE ADJUTANT MOVES INTO POSITION)
"PRESENT DAY PARADES IN THE MARINE CORPS HAVE THEIR BASIS IN BOTH HISTORY AND TRADITION, THE MASSED FORMATION OF TROOPS ON ONE LONG LINE AT CLOSE INTERVAL, MADE POSSIBLE THE MASSING OF FIREPOWER FROM MUZZLE LOADED MUSKETS OF THE PAST. THE ADJUTANT FORMS THE LINE OF BATTLE, AND IN THOSE EARLY DAYS, THAT LINE CONSISTED OF TWO OR THREE RANKS, MUCH LIKE IN THE PARADE YOU WILL SEE TODAY."

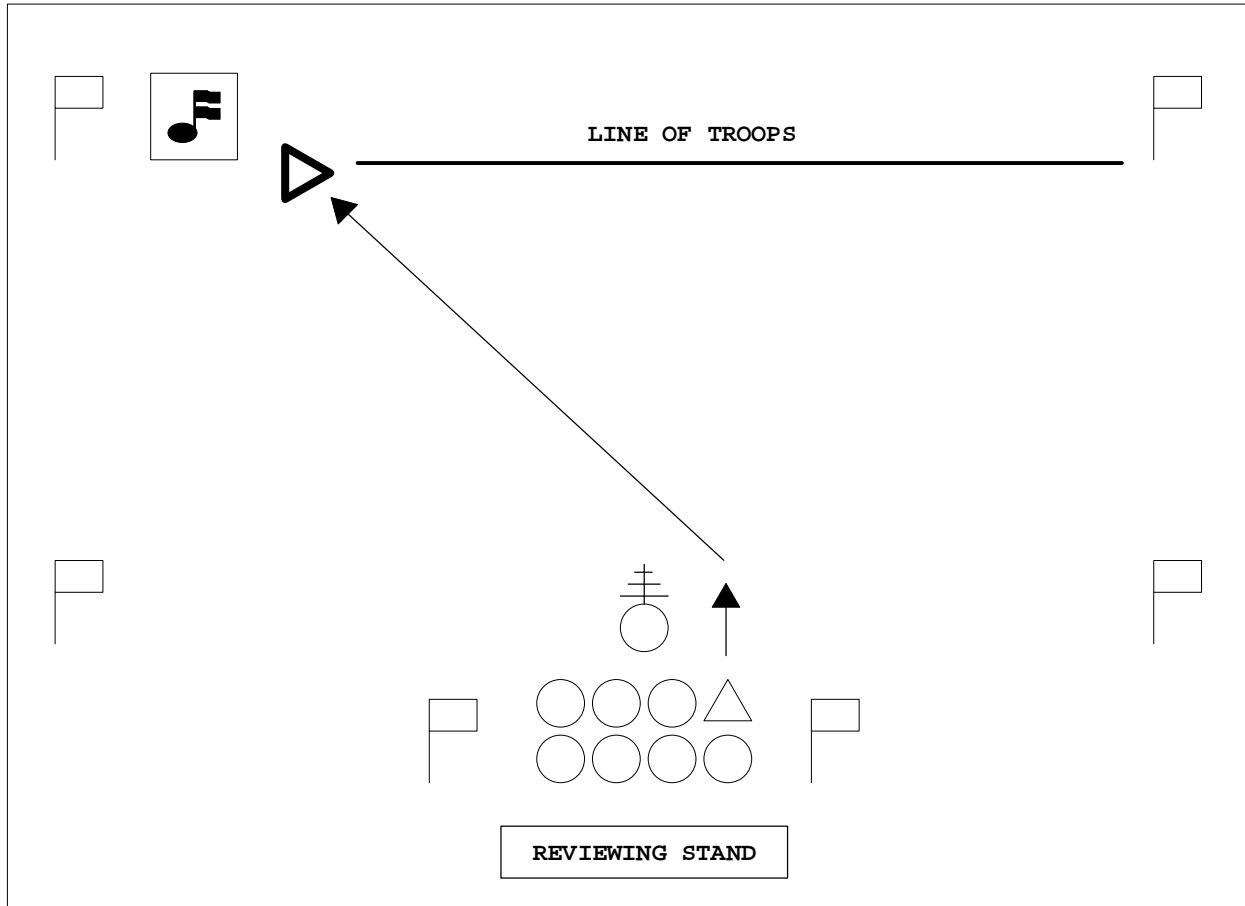

Figure 5-2.--Adjutant Moves to Post.

6. Sequence of Events for Forming a Battalion and Larger Units

- a. To form a battalion for march on see enclosure 1, chapter 11.
- b. To form a regiment see enclosure 1, chapter 12
- c. Color Guard

(1) If awards, retirements, etc., are a part of the parade, the color guard will march onto the parade field with the battalion, when approaching its position on the line of march, the color guard will execute a left turn, march forward to their position in the line of troops, mark time, halt and go to order colors. The color guard will execute all commands with the color company except that it will remain at the order during the manual of arms.

(2) If no awards, retirements, etc., are a part of the parade, and the commander wants to "troop the colors," the color guard would execute a left turn at the extreme left edge of the parade field. It then marches to a position on the left flank of the field, half way between the line of company commanders and the adjutant's position. The color guard executes a right turn and goes to order colors. (See enclosure 1, chapter 7, paragraph 7.)

d. Upon completion of forming the unit and if prescribed for the ceremony, the adjutant next commands "**Fix, BAYONETS.**" After fixing bayonets,

or after posting the guide if bayonets are not fixed, the adjutant continues the sequence from paragraph 6.e. or 6.i. below as appropriate.

Note: If colors are to be marched on, continue the sequence with paragraph 6.e. below. Narrator would announce, "**LADIES AND GENTLEMEN, PLEASE RISE FOR THE PRESENTATION OF COLORS.**" If colors are not to be marched on, skip to paragraph 6.i.

e. Adjutant commands "**MARCH ON THE COLORS.**" The band plays appropriate music while the color guard, goes to the carry, marches from its position on the left flank, across the front of the battalion along a line parallel to the line of troops and midway between the adjutant and line of company commanders. Company commanders and the company guide salute the colors as they pass their front. On reaching a point in front of the adjutant, the color guard executes a left turn to face the adjutant and halts, remaining at the carry.

f. Adjutant commands "**Present, ARMS.**" The battalion executes present arms. The adjutant salutes the colors.

(1) The color guard executes present arms from the carry.

(2) The band plays either "*To the Colors*" or the "*National Anthem.*" The commander of troops, the staff, and the organizational colors salute on the first note of the music and terminate the salute on the last note.

g. Adjutant commands "**Order, ARMS.**" The command executes order arms. The color guard returns to carry colors. Narrator would announce, "**LADIES AND GENTLEMEN, PLEASE BE SEATED.**"

h. Adjutant commands "**POST THE COLORS.**" The color guard countermarches, moves to the line of troops on the left of the color company, countermarches to face the front, halts, and goes to order colors.

i. Adjutant commands "**Parade, REST**" and "**SOUND OFF.**" The battalion executes. The adjutant, commander of troops, and staff go to parade rest on the command of the commander of troops. The band sounds off, marches down the line of troops, countermarches, marches back down the line of troops and returns to its position in formation. Once the band is back in position and has stopped playing; (Figure 5-3 depicts the movement of the band during sound off.)

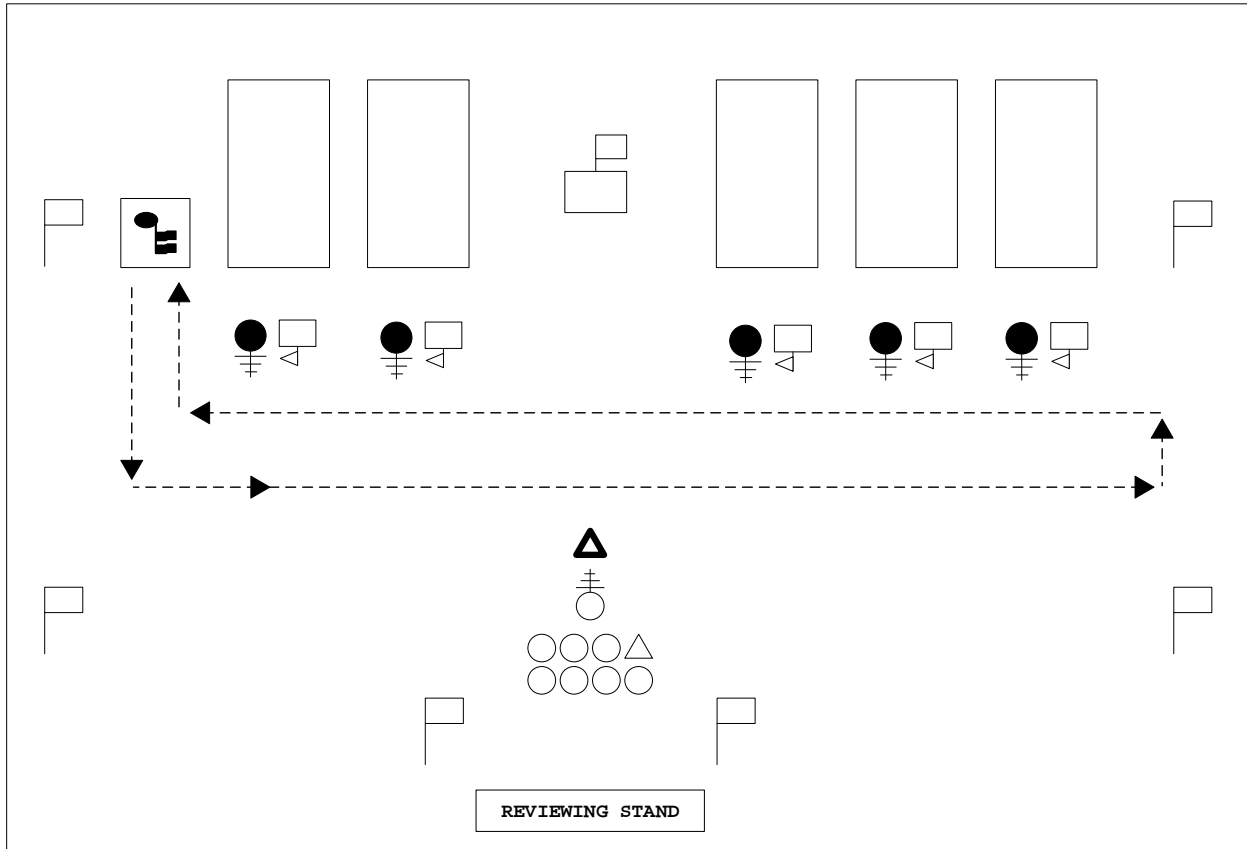

Figure 5-3.--Sound Off.

j. The adjutant assumes attention on their own. The commander of troops, after the adjutant assumes the position of carry sword, brings his/her staff to attention. The Adjutant commands **"Battalion, ATTENTION"** and **"Present, ARMS."** The battalion executes attention and present arms. The color guard riflemen execute present arms, and the colors go to the carry. However, the commander of troops does not receive a salute from the organizational colors unless the commander of troops is the battalion commander or officer of higher rank. Once the battalion is at present arms, the adjutant faces the commander of troops and reports.

7. Sequence of Events for Presentation of the Command

a. Adjutant reports **"SIR/MA'AM, THE PARADE IS FORMED."** The commander of troops returns the adjutant's salute.

b. Commander of troops commands **"TAKE YOUR POST."** The adjutant returns to carry swords and marches by the most direct route to the designated post in the staff, halts, faces the line of troops and goes to order sword.

c. Commander of troops commands (only loud enough for the staff to hear) **"Staff, Draw, SWORD"** and **"Staff, Order, SWORD"** (omitted if not armed with swords). The commander of troops remains at carry sword. The commander of troops then exercises the battalion in the manual of arms.

d. Commander of troops commands **"Order, ARMS;" "Port, ARMS;" "Right**

Shoulder, ARMS;" "Port, ARMS;" "Left Shoulder, ARMS;" "Port, ARMS;" and "Order, ARMS." The battalion executes the manual of arms on the orders of the commander of troops.

(1) Company officers and noncommissioned officers execute carry swords of the first command of port arms and return to order swords on the final command of order arms.

(2) The color guard remains at the order during the manual of arms.

e. After the manual of arms is completed, the commander of troops directs the adjutant to **"RECEIVE THE REPORT, SIR/MA'AM."** The adjutant goes to carry sword and moves to a position 3 paces in front of the commander of troops, facing the line of troops.

f. Adjutant commands **"REPORT."** Company commanders, in succession, from right to left, salute the adjutant with their head and eyes to the front and report, " Company, All Present or Accounted For." The adjutant turns his/her head towards the company commander reporting, but returns the head to the front when returning each company commander's salute. After the last company has reported, the adjutant faces the commander of troops and reports "Sir/Ma'am, All Present or Accounted For." The commander of troops returns the adjutant salute, returns to carry sword (the commander of troops remains at carry sword, except when saluting, during the execution of officers center and officers posts).

g. Commander of troops commands **"PUBLISH THE ORDERS."** The adjutant terminates the salute, faces the line of troops and publishes the orders.

h. Adjutant commands **"ATTENTION TO ORDERS."**

Note: "Headquarters, Battalion Marines, (date), (month), (year), The Officer of the day today is (rank and name), The Officer of the day tomorrow is (rank and name). By order of (battalion commander's rank and name), United States Marine Corps (Reserve), Commanding."

i. Adjutant commands **"OFFICERS"-"CENTER"-"MARCH."** (A sufficient pause between the above command is necessary for the officers and guides to execute the movements.) Figure 5-4 depicts movement for officers center. On the command **"OFFICERS,"** the company commanders and platoon commanders go to carry sword, if so armed. The company guide goes to carry guidon.

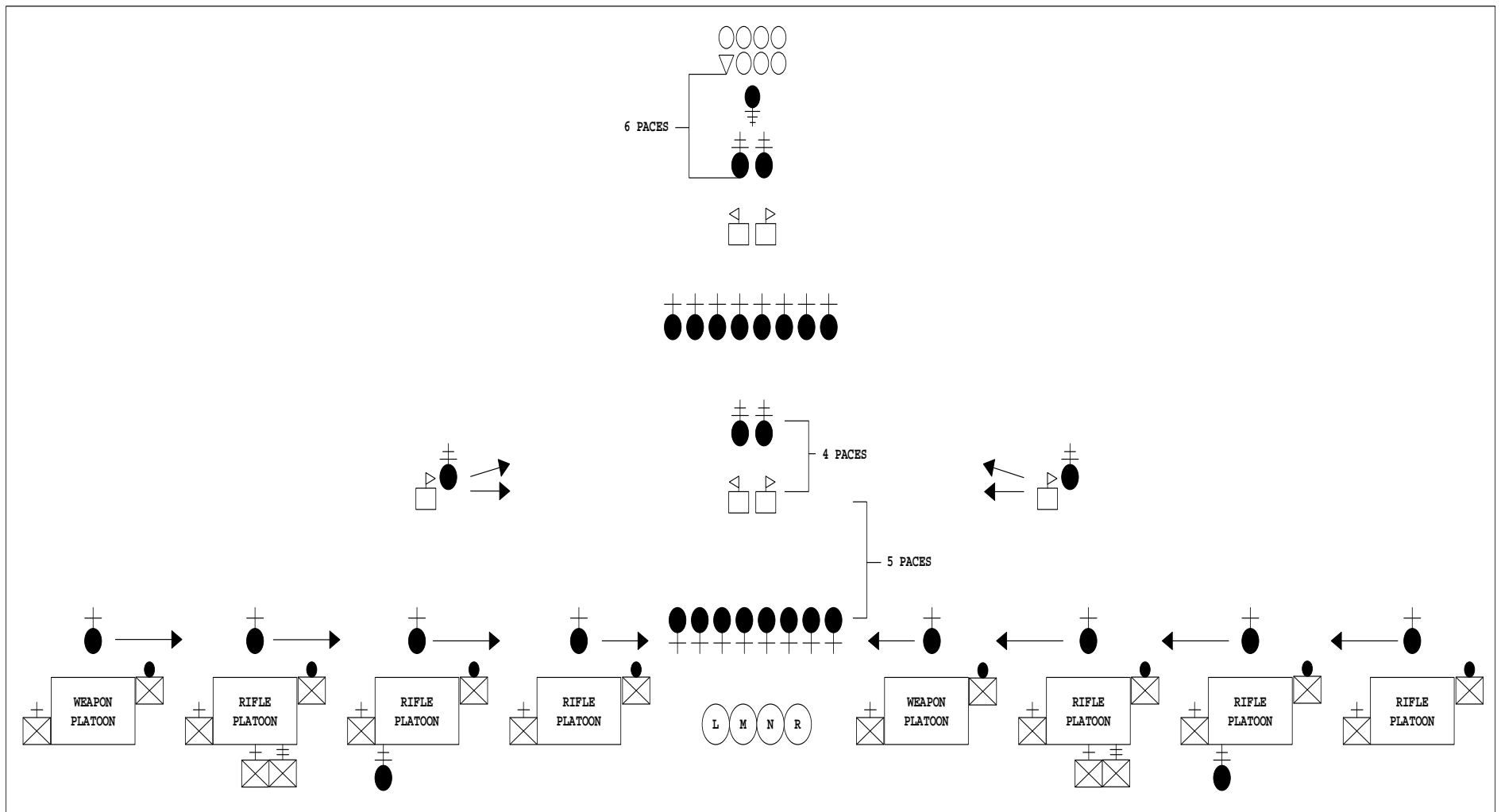

Figure 5-4.--Officers Center.

Note: If the parade is being conducted in conjunction with a review then officers center is omitted.

(1) On the command "**CENTER.**"

(a) If in battalion line, company line, company commanders, platoon commanders and company guides face left/right towards the center of the parade field.

(b) If in a battalion line, company mass formation, company commanders and guides face left/right towards the center of the parade field. Platoon commanders take one step forward, halt and then face left/right towards the center of the parade field.

(c) Platoon guides stand fast.

(2) On the command "**MARCH.**"

(a) The band starts playing.

(b) The adjutant returns by the most direct route to the designated position in the staff and goes to order sword.

(c) The platoon commanders and guides march directly to their positions in the center of the parade field halt and face left/right towards the commander of troops at close interval.

(d) The company commanders oblique slightly forward in order to form on a line approximately 4 paces in front of the line of guides.

j. Once all officers and guides have halted and faced the commander of troops, the senior company commander commands, "**Officers, Forward, MARCH.**" As the ranks of officers and guides advance towards the commander of troops, alignment is maintained towards the center, with the officer in the center of the leading rank setting the step and direction.

k. As they approach the commander of troops, the senior company commander commands "**Officers, HALT.**" The ranks of officers and guides are halted approximately 6 paces from the commander of troops and salute.

(1) If armed with swords, the officers and guides execute a four-count halt. On the first two counts, the officers and guides execute a halt. On the third count, the officers execute the first count of present swords. For the fourth count, the officers execute the second count of present swords and the company guides present guidons.

(2) If not armed with swords, the officers and company guides execute a four-count halt. On the first two counts, the officers and guides execute a halt. On the third count all pause, and on the fourth count, the officers execute a hand salute and the company guides present guidons.

(3) The commander of troops returns the salute. The commander of troops terminates the salute on the same command which terminates those of the officers' party.

l. Commander of troops commands "**Carry, SWORD**" (If armed with swords) or "**Ready, TWO**" (If not armed with swords).

(1) On the command "**Carry,**" the officers execute order swords, if so armed. The guides re-grasp the guidon as the first count of carry guidon. When not armed with swords, on the command "**Ready,**" the officers stand-fast and guides re-grasp the guidon as the first count of carry guidon.

(2) On the command "**SWORD (TWO),**" the officers go to carry swords, if so armed, and the guides go to carry guidon. If not armed with swords, the officers cut their salute. The commander of troops then commands.

m. Commander of troops commands "**POST**"-"**MARCH**." Figure 5-5 depicts post march.

(1) On the command of "**POST**," officers and guides execute an about face.

(2) On the command of "**MARCH**," officers and guides step off and march back towards the battalion formation. Alignment is maintained towards the center, with the officer in the center of the leading rank setting the step and direction.

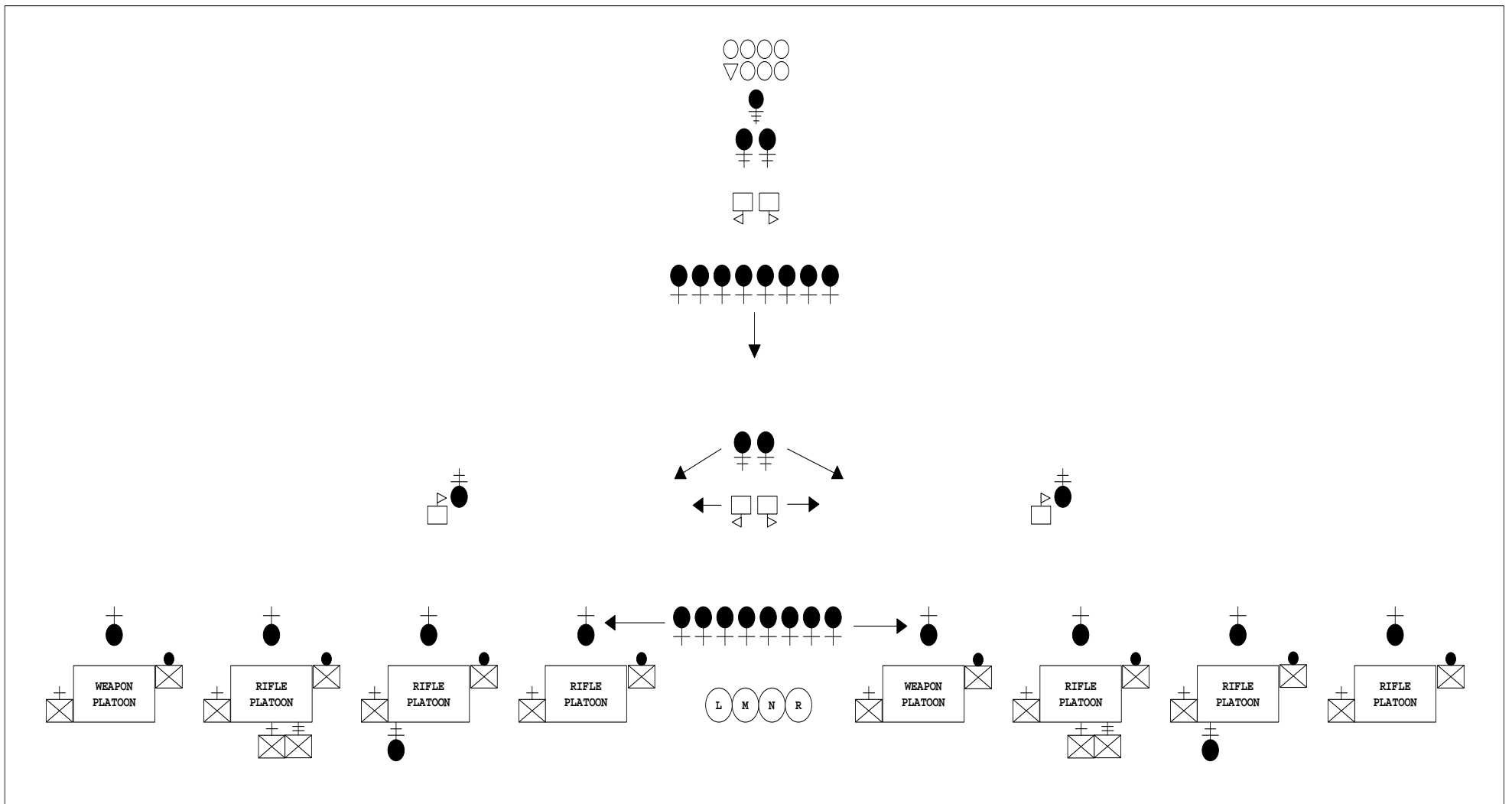

Figure 5-5.---Post March.

n. When the officers are nearing the battalion formation, the senior company commander commands "**Officers, HALT;**" and "**POST"-"MARCH.**" The officers are halted so that:

(1) When in a battalion line, company line, and the rank of platoon commanders are 6 paces from the line of troops.

(2) When in a battalion line, company mass, the rank of platoon commanders are two paces from the line of troops.

(3) On the command of "**POST,**" officers and guides face left/right in the direction of their companies.

(4) On the command of "**MARCH,**" officers and guides step off in succession at four-pace intervals. (The Marine at the head of each file steps off, then every fourth step the next Marine steps off so as to be in step with the music.) Then, by the most direct route, return to their posts, halt, face front and execute order swords.

(a) If in a company mass formation, upon reaching their platoons, the platoon commanders will execute one step to the right/left flank into their position, halt, about face and go to order sword.

(b) Guidon bearers step off with their company commander and when reaching their post, halt, face front and go to order guidon.

(c) Company commanders oblique inboard so that they are one pace in front of their guidon bearer upon reaching their post. They halt, face front and go to order sword.

(5) When all officers and guides have returned to their posts, and gone to the order, the band stops playing. The commander of troops then, so only the staff can hear, commands.

o. Commander of troops commands "**BOX THE STAFF.**" (enclosure 2, chapter 2, paragraph 3.c.)

(1) The adjutant boxes the staff by giving the following commands;

(a) "**Staff, Carry, SWORD**" (if armed with swords).

(b) "**Staff, Left, FACE.**"

(c) "**Staff, Column Right, MARCH**" (second column right is executed without command. Once each staff member has reached their new position, they automatically mark time).

(d) "**Staff, HALT.**"

(e) "**Staff, Right, FACE.**"

(f) "**Staff, Order, SWORD**" (if armed with swords).

(2) Once the staff is in its new position, the commander of troops faces the reviewing area. The reviewing officer then takes position centered between the dress guidons at attention. The commander of troops, seeing the reviewing officer in position, faces the battalion.

Note: If the reviewing officer is a general or flag officer, or civilian that rates "honors," the following sequence will be used beginning with paragraph 7.p. The procedures for honors and gun salutes are contained in enclosure 2, chapter 10. If no musical or gun salutes are due to the reviewing officer skip to paragraph 7.t.

NARRATOR: "LADIES AND GENTLEMEN, PLEASE RISE FOR HONORS TO (TITLE/RANK AND NAME OF THE PERSON TO RECEIVE HONORS)." (e.g.; "THE SECRETARY OF DEFENSE, THE HONORABLE PATRICK M. SHANAHAN." OR "THE COMMANDANT OF THE MARINE CORPS, GENERAL ROBERT B. NELLER."

p. Commander of troops commands "**Present, ARMS.**" The command executes present arms.

(1) The color guard executes present arms from the order. If no musical or gun salute is fired, the organizational colors salutes, if appropriate. If musical or gun salutes are utilized, the organizational colors salute on the first note of music and returns to the carry on the last note of the music, or last gun is fired.

(2) Once the battalion is at present arms the commander of troops faces the reviewing area.

q. Commander of troops commands "**Staff, Present, SWORD (ARMS).**" The staff and commander of troops present swords. After honors, if any, the reviewing officer returns the salute of the commander of troops.

r. Commander of troops commands "**Staff, Order, SWORD (ARMS).**" The commander of troops and staff go to order swords. The commander of troops returns to carry sword and faces the battalion.

s. Commander of troops commands "**Order, ARMS.**" The battalion executes order arms. The commander of troops then faces the reviewing area.

t. Note. At this time if:

(1) The parade is being held as part of a review, refer to enclosure 2, chapter 4 and follow that sequence of events.

(2) The parade is being held as an awards/retirement ceremony, refer to enclosure 2, chapter 6, and follow the sequence of events specified for the presentation of awards/retirement.

(3) The parade is being held for a change of command ceremony refer to enclosure 2, chapter 7 and follow the sequence of events specified for a change of command.

(4) The parade is being held for a relief and appointment of the sergeants major refer to enclosure 2, chapter 8 and follow the sequence of events specified for the relief and appointment of the sergeant major.

(5) If the parade is being held for an activation/deactivation, or a joint activation/deactivation ceremony refer to enclosure 2, chapter 9 and follow the sequence of events for the specific ceremony outlined there.

u. After completing one of the above sequences of events, return to this Chapter and continue with the sequence of events for marching in review.

8. Sequence of Events to March in Review in Column from a Battalion Line, Company Line Formation

a. After completing the presentation of awards, retirements, etc., and the battalion is at attention, the commander of troops faces the reviewing officer.

b. Reviewing officer commands "**MARCH THE COMMAND IN REVIEW.**" After exchanging salutes, the commander of troops commands "**Staff, Carry, SWORD,**" and then faces the line of troops.

c. Commander of troops commands "**PASS IN REVIEW**" and "**Right, FACE.**" While the battalion is being prepared to march in review, the band moves to its position on the line of march.

(1) On the command "**PASS IN REVIEW,**" all personnel armed with sword will execute carry sword.

(2) On the command of execution "**FACE,**" all hands face to the right. The platoon guides move to their position in front of the right squad. The platoon commanders move to their position at the head of their platoons. The company commanders and company guides then move to their positions at the head of their companies. (See figure 5-6.)

(3) The color guard, on the command "**Right, FACE,**" goes to carry colors, executes a right turn, halts and remains at the carry.

d. Commander of troops commands "**Right Shoulder, ARMS.**" The battalion executes right shoulder arms. The commander of troops then glances in the direction of the band to ensure it is ready to march in review. The drum major signifies the band is ready by having halted the band and raising the mace in a high carry position.

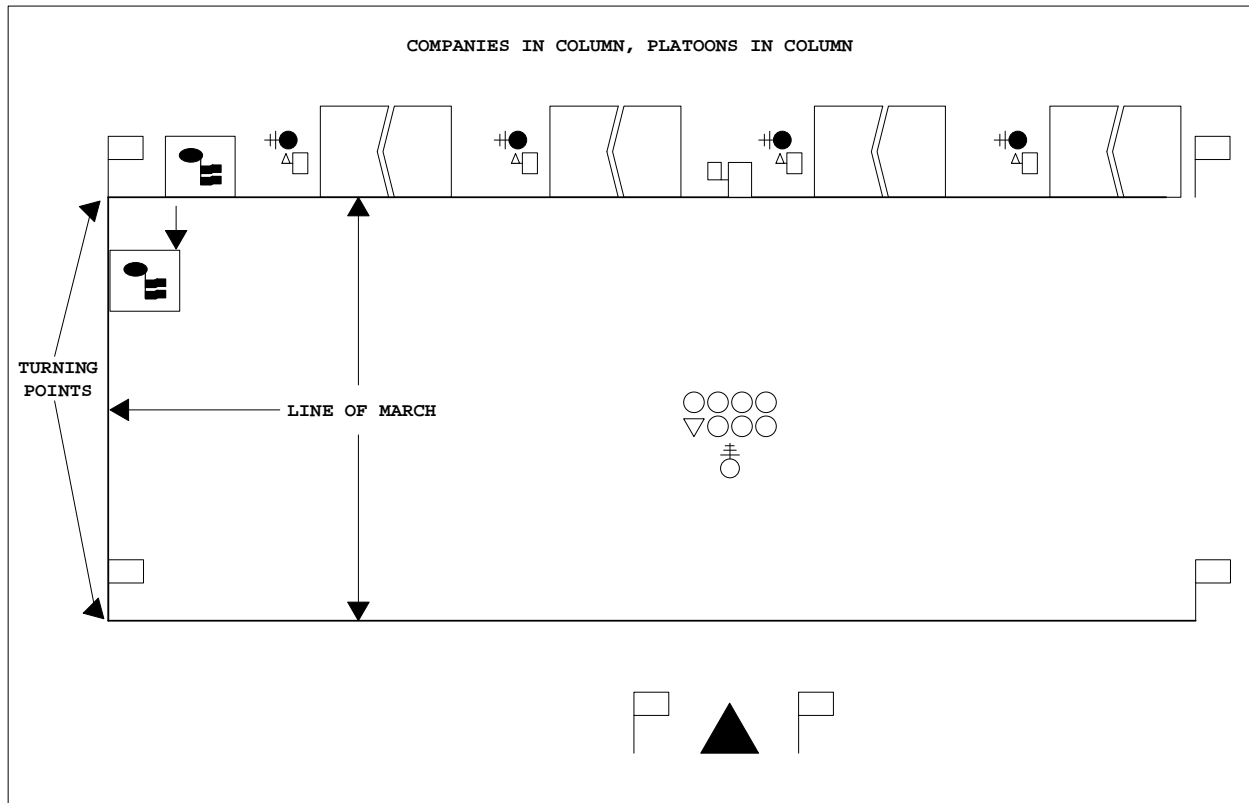

Figure 5-6.--Right Face.

e. Commander of troops commands **"Forward, MARCH."** The entire battalion steps off and the band plays *"Semper Fidelis."* The formation quickly adjusts its step so that the left foot strikes the deck in time with the heavy beat of the drum.

(1) The commander of troops and staff step off when the command of execution **"MARCH"** is given by the commander of troops. The commander of troops steps to the left in marching and picks up the half step. The staff executes a right turn from the halt, and covers on the commander of troops. When the staff has completed the turn, the commander of troops commands **"Staff, Forward, MARCH."**

(2) The commander of troops and staff marches down the line and execute two left turns in order to be positioned at the head of the column in front of the band. (See figure 5-7.)

(3) The company commanders, as they approach each turning point give the command of **"Column Left, MARCH"** for themselves and the company guide. Platoon commanders give their platoons **"Column Left, MARCH"** in order to maintain their positions in the company column. (See figure 5-7.)

(4) The color guard executes left turns at the turning points.

(5) All column movements are made "inside" the line formed by the dress guidon. The platoon guides use the dress guidons as markers to set the direction of march for the platoon.

f. As the commander of troops, band, company commanders, platoon commanders and the color guard approach the reviewing area, the command of eyes right will be given.

(1) As the commander of troops and the staff approach the reviewing area, the commander commands **"Staff, Eyes, RIGHT,"** and as the reviewing area is cleared, **"Staff, Ready, FRONT."**

(a) The commander of troops and the staff continue to march down the line of troops to the end of the reviewing area, or other designated point, where they will turn out of the line of march and be positioned to observe the march in review (e.g., they may execute three right turns, see enclosure 2, chapter 2, figure 2-8).

(b) The commander of troops, after the staff is halted, commands **"Staff, Return, SWORD,"** if so armed. The commander of troops gives the commands of **"Hand, SALUTE,"** and **"Ready, TWO,"** as the color guard passes the staff's position.

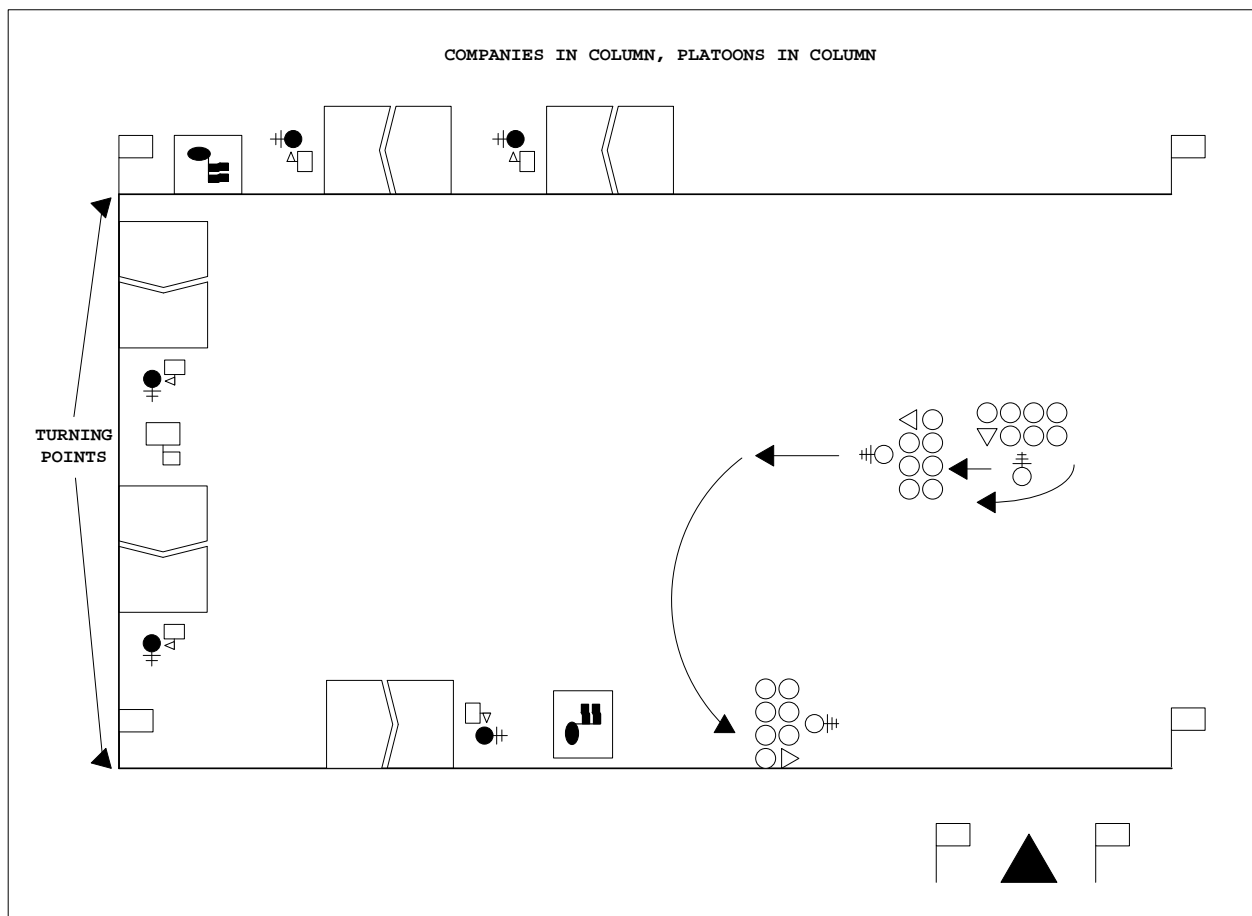

Figure 5-7.--March in Review, Companies in Column.

(2) As the band passes the reviewing area, the drum major executes an eyes right and salutes for the band. After clearing the reviewing area, the band is marched to a position approximately 30 paces from the reviewing area, centered on and facing the reviewing officer. The band continues to play march music during the march in review.

(3) As each company commander approaches the reviewing area, the commander gives the command of **"Eyes, RIGHT"** for themselves and the company guide. Both the company commander and guide will turn their heads to the right 45 degrees. After passing the second dress guidon, the company commander commands **"Ready, FRONT."** The company continues to march down the line of march and from the field.

(4) Platoons execute **"Eyes, RIGHT"** on the command of their platoon commander. After the rear of the platoon has cleared the reviewing area, the platoon commander then commands **"Ready, FRONT."**

(5) The color guard executes eyes right and ready front on command of the senior color bearer per enclosure 1, chapter 7, paragraph 10. The organizational colors salute during eyes right if the reviewing officer rates such a salute.

g. If armed with swords, only the company commanders and platoon commanders execute a sword salute at eyes right. All other officers and enlisted personnel armed with swords, in the company/platoon formation, continue to march at carry sword.

h. As the last company begins executing eyes right, the band plays any special music requests, if required, immediately followed by the *"Marines' Hymn."* As the *"Marines' Hymn"* is being played, the drum major faces the reviewing officer and salutes. The reviewing officer returns the salute. The band then picks up march music, marches forward, executes a left turn and marches from the field.

i. After the rear element of the command (normally the band) has passed the staff's position and exited the field, the commander of troops faces the reviewing officer, salutes and reports "Sir/Ma'am, the parade is concluded." After the salute is returned, the commander of troops may:

(1) Draws sword with the staff and follow the battalion from the field.

(2) Dismiss the staff.

<p>NARRATOR: "LADIES AND GENTLEMEN, THIS CONCLUDES TODAY'S CEREMONY. ON BEHALF OF THE COMMANDING OFFICER (GENERAL), OFFICERS AND MARINES OF _____, THANK YOU FOR YOUR ATTENDANCE. SEMPER FIDELIS."</p>

j. After marching off of the parade ground following the march in review, the color guard and color company return the colors as prescribed in enclosure 1, chapter 7. Companies march to their respective areas and are dismissed.

9. Sequence of Events to March in Review in Column from a Battalion Line, Company Mass Formation

a. After completing the presentation of awards, retirements, etc., and the battalion is at attention, the commander of troops faces the reviewing officer.

b. Reviewing officer commands "**MARCH THE COMMAND IN REVIEW.**" After exchanging salutes, the commander of troops commands "**Staff, Carry, SWORD,**" and then faces the line of troops.

c. Commander of troops commands "**PASS IN REVIEW,**" all personnel armed with swords will execute carry sword.

(1) While the battalion is being prepared to march in review, the band moves to its position on the line of march.

(2) Company commanders, on the command to pass in review, go to carry sword and face their companies. The company commander of the right company in line begins the pass in review.

d. Company Commander commands "**Right Shoulder, ARMS.**"

(1) The company goes to right shoulder arms.

(2) When the company is at right shoulder arms, the lead company commander glances in the direction of the band to ensure it is ready to march in review. The drum major signifies the band is ready by having halted the band and raising the mace in a high carry position. The company commander of the right company then commands;

e. Company Commander commands "**Column of Threes (Fours), Right Platoon, Column Right, MARCH.**"

(1) On the command of execution "**MARCH,**" by the company commander of the right company;

(a) The platoon on the right flank of the company executes a column right from the halt.

(b) The band steps off and plays "*Semper Fidelis.*" The formation quickly adjusts its step so that the left foot strikes the deck in time with the heavy beat of the drum.

(c) The company commander and company guide step off and march parallel to the line of troops. They execute a column left at the second change of direction to position themselves in front of the lead platoon of the company at the proper interval.

(d) The commander of troops steps to the left as in marching and picks up the half step. The staff executes a right turn from the halt, and covers on the commander of troops. When the staff has completed the turn, the commander of troops commands "**Staff, Forward, MARCH.**" The commander of troops and staff marches down the line and execute two left turns in order to be positioned at the head of the column in front of the band. (See figure 5-7.)

(2) The second and subsequent platoon commanders, seeing their platoons about to be uncovered by the platoon on the right command "**Column Right, MARCH**" so that the platoon is in step with and at the proper interval from the platoon to its front in the column. (See figure 5-8.)

(3) Subsequent company commanders give the commands of "**Right Shoulder, ARMS**" and "**Column of Threes (Fours), Right Platoon, Column Right,**

MARCH" in order to march their companies in review in step with and at the proper interval from the company to its front in the column.

(4) The color guard executes carry colors when the company commander of the color company commands **"Right Shoulder, ARMS."** The color guard then makes those movements necessary to march in review at the proper interval from the color company.

(5) The platoon commanders, as they approach the first turning point, give their platoons **"Column Left, MARCH."** (See figure 5-7.)

(6) The color guard executes left turns at the turning points.

(7) All column movements are made "inside" the line formed by the dress guidons. The platoon guides use the dress guidons as markers to set the direction of march for the platoon.

(8) The company commanders, as they approach the second turning point, give the command of **"Column Left, MARCH"** for themselves and the company guides. Platoon commanders give their platoons **"Column Left, MARCH"** in order to maintain their positions in the company column. (See figure 5-7.)

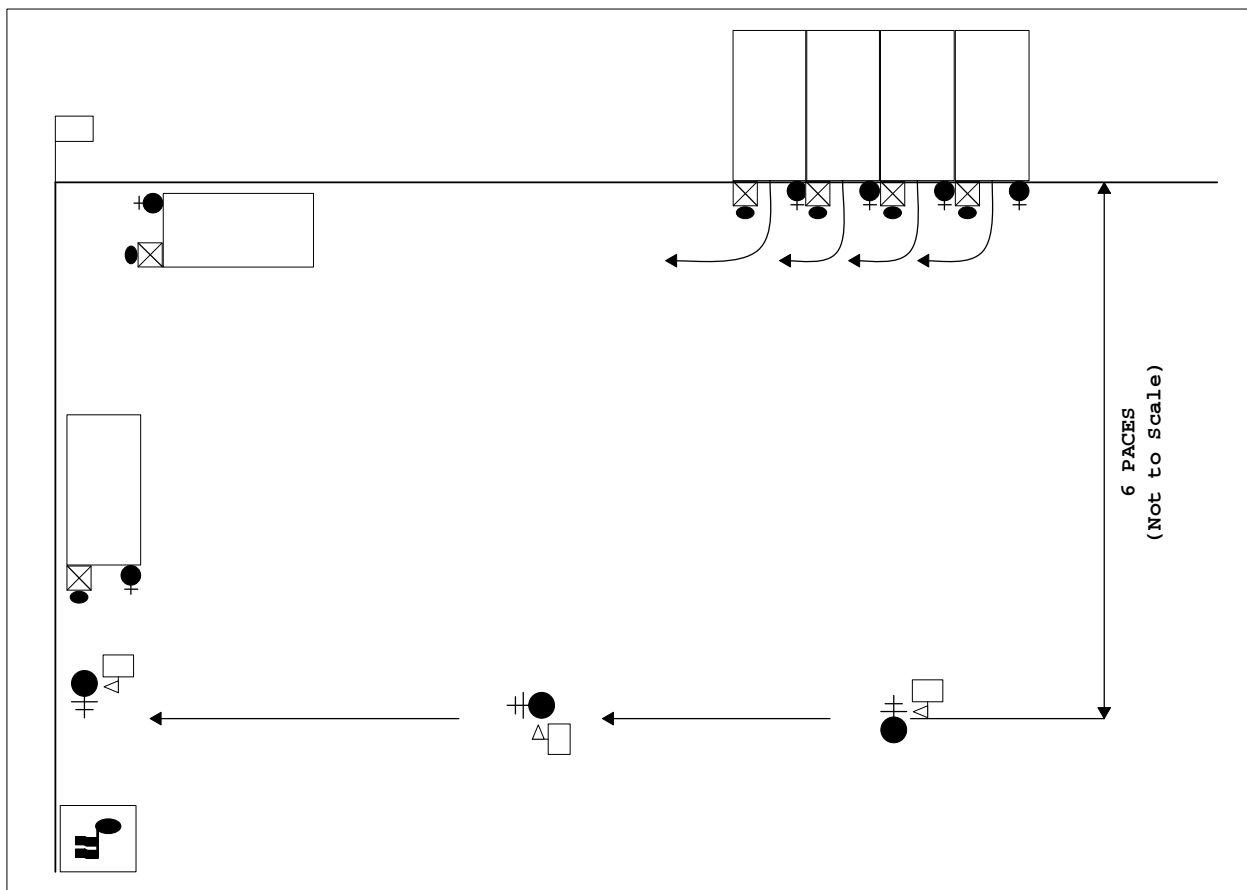

Figure 5-8.--Column of Threes, From the Right.

f. Refer to paragraph 8.f. for the remainder of the sequence of events for the pass in review.

10. Sequence of Events to March in Review in Battalion Column, Companies in Mass

a. After completing the presentation of awards, retirements, etc., and the battalion is at attention, the commander of troops faces the reviewing officer.

b. Reviewing Officer commands "**MARCH THE COMMAND IN REVIEW.**" After exchanging salutes, the commander of troops commands "**Staff, Carry, SWORD,**" and then faces the line of troops.

c. Commander of troops commands "**PASS IN REVIEW**" and "**Right Shoulder, ARMS.**" The battalion executes right shoulder arms. While the battalion is being prepared to march in review, the band moves to its position on the line of march.

(1) On the command of "**PASS IN REVIEW,**" all personnel armed with swords will execute carry sword.

(2) The color guard, on the command of execution "**ARMS,**" goes to carry colors, executes a right turn, halts and remains at the carry.

(3) The commander of troops then glances in the direction of the band to ensure it is ready to march in review. The drum major signifies the band is ready by having halted the band and raising the mace in a high carry position. When the band and the battalion is prepared to march in review;

d. Commander of troops commands "**Column of Companies, Right Company, Right Turn-MARCH.**" The right company executes a right turn from the halt and picks up the half step. After the company has completed making the turn, the company commander commands "**Forward, MARCH.**"

(1) The band steps off and plays "*Semper Fidelis.*" The formation quickly adjusts its step so that the left foot strikes the deck in time with the heavy beat of the drum.

(2) The commander of troops and staff step off on the command of execution "**MARCH.**" The commander of troops steps to the left as in marching and picks up the half step. The staff executes a right turn from the halt, and covers on the commander of troops. When the staff has completed the turn, the commander of troops commands "**Staff, Forward, MARCH.**"

(3) The commander of troops and staff marches down the line and execute two left turns in order to be positioned at the head of the column in front of the band. (See figure 5-7.)

(4) The company commanders, as they approach each turning point, give the command of "**Left Turn, MARCH**" and "**Forward, MARCH**" to march the company in review. All turning movements are made "inside" the line formed by the dress guidon. The guide of the right platoon of the companies use the dress guidons as markers to set the direction of march for the platoon. (See figure 5-9.)

(5) The color guard executes left turns at the turning points.

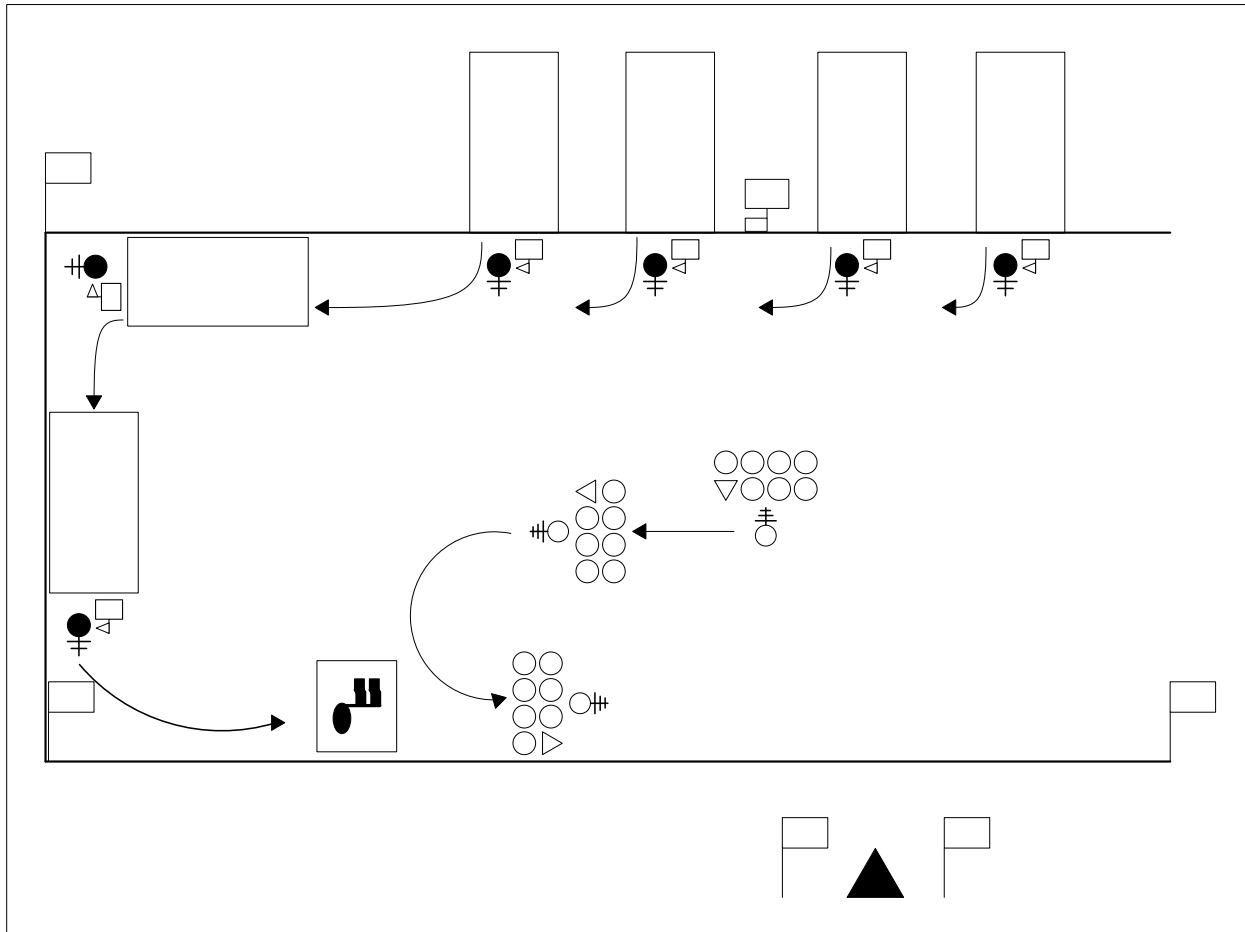

Figure 5-9.--March in Review, Companies in Mass.

e. As the commander of troops, band, company commanders and the color guard approach the reviewing area, the command of eyes right will be given;

(1) As commander of troops and the staff approach the reviewing area, the commander commands "**Staff, Eyes, RIGHT,**" and as the reviewing area is cleared, "**Staff, Ready, FRONT.**"

(a) The commander of troops and the staff continue to march down the line of troops to the end of the reviewing area, or other designated point, where three right turns are executed in order to place the staff in position to observe the march in review. (See enclosure 2, chapter 2, figure 2-8.)

(b) The commander of troops, after the staff is halted, commands the staff to "**Staff, Return, SWORD,**" if so armed. The commander of troops gives the commands of "**Hand, SALUTE,**" and "**Ready, TWO,**" as the color guard passes the staff's position.

(2) As the band passes the reviewing area, the drum major executes an eyes right and salutes for the band. After clearing the reviewing area, the band is marched to a position approximately 30 paces from the reviewing area, centered on and facing the reviewing officer. The band continues to play march music during the march in review.

(3) As each company commander approaches the reviewing area, the Marine gives the command of **"Eyes, RIGHT."** The company executes eyes right on the command of the company commander. After the rear of the company has cleared the reviewing area, the company commander commands **"Ready, FRONT."** The company continues to march down the line of march and from the field.

(4) The color guard executes eyes right and ready front on command of the senior color bearer. The organizational colors salute during eyes right if the reviewing officer rates such a salute.

(5) If armed with swords, only the company commanders and the officers in the front rank of the company execute a sword salute at eyes right. All other officers and noncommissioned officers armed with swords, in the company/platoon formation, continue to march at carry sword.

f. As the last company begins executing eyes right, the band plays any special music requests, if required, immediately followed by the *"Marines' Hymn."* As the *"Marines' Hymn"* is being played, the drum major faces the reviewing officer and salutes. The reviewing officer returns the salute. The band then picks up march music, marches forward, executes a left turn and marches from the field.

g. After the rear element of the command (normally the band) has passed the staff's position and exited the field, the commander of troops faces the reviewing officer, salutes and reports **"Sir/Ma'am, the parade is concluded."** After the salute is returned, the commander of troops may:

- (1) Draw sword with the staff and follow the battalion from the field.
- (2) Dismiss the staff.

NARRATOR: "LADIES AND GENTLEMEN, THIS CONCLUDES TODAY'S CEREMONY. ON BEHALF OF THE COMMANDING OFFICER (GENERAL), OFFICERS AND MARINES OF _____ THANK YOU FOR YOUR ATTENDANCE. SEMPER FIDELIS."

h. After marching off of the parade ground following the march in review, the color guard and color company returns the colors as prescribed in chapter 7. Companies march to their respective areas and are dismissed.

11. To March in Review, Companies in a Column of Platoons in Line

a. The sequence of events to march in review in company column, platoons in line (see figure 5-10), is the same as specified in paragraphs 9 and 10 up through the first column left.

b. After making the initial column left, platoon commanders step to the left of the column and position themselves six paces front and centered on their platoons.

c. The company commander and company guide execute a left flank approximately 10 paces short of the second turn marker so as to be centered in front of the platoon in line.

d. The platoon commanders give their platoons the command of **"By the**

Left Flank, MARCH" so that the platoon guide is marching down the line of march. The guide, after executing the flanking movement, moves up to a position beside the first squad leader.

e. When passing the reviewing area, the company commander gives the commands **"Eyes, RIGHT"** and **"Ready, FRONT"** for himself/herself and the company guide only.

f. Platoon commanders will give the commands **"Eyes, RIGHT"** and **"Ready, FRONT"** to their platoons.

g. After passing in review, and when reaching the designated spot (far enough away from the reviewing area so as not to interfere with following companies passing in review), the company returns to column formation, by executing a right flank and then executing a column left to depart the field.

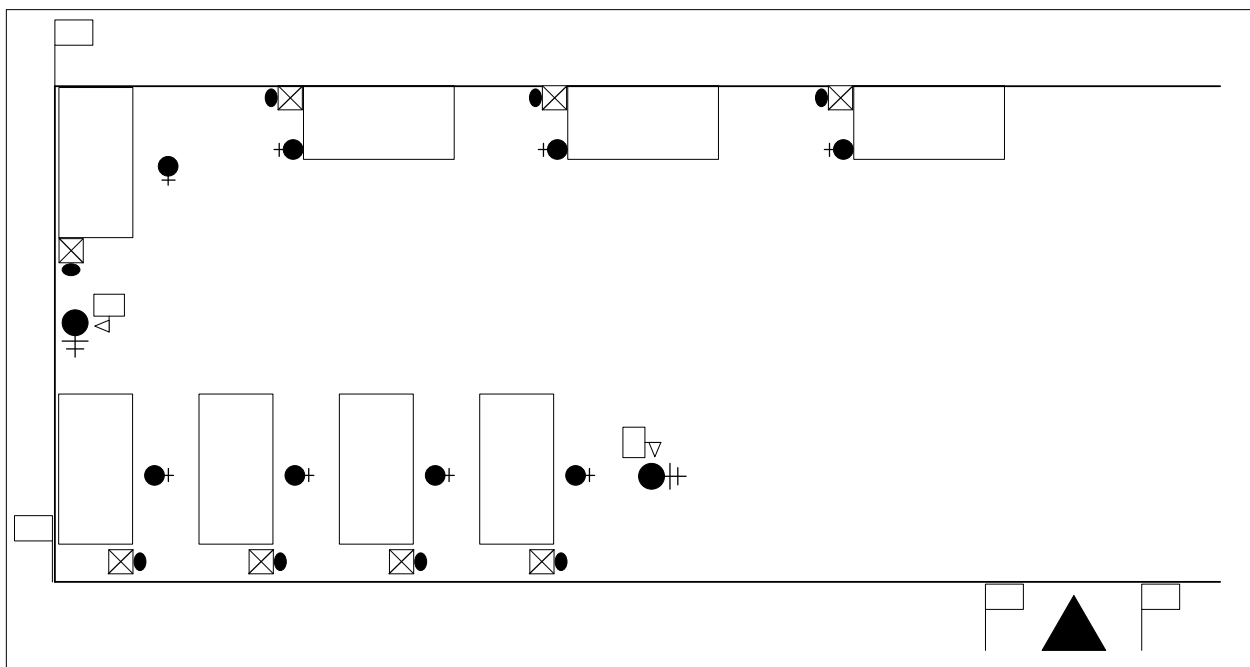

Figure 5-10.--Marching in Review, Companies in Column of Platoons on Line.

12. Regimental Parades. The regiment normally forms in line of battalions with companies in line or in mass formation to conduct ceremonial parades. The parade proceeds as for the battalion with the following exceptions:

a. Regiment is substituted for battalion in description.

b. Battalions and independent companies form the regiment as prescribed in enclosure 1, chapters 10 and 11.

c. Battalions and independent companies execute movements on the command of their respective commanders. The battalion and independent company commanders make reports to the regimental adjutant.

d. When trooping the line, after **"Sound Off,"** the band passes midway between the line of battalion commanders and the regimental adjutant.

e. During officers center, battalion commanders and staffs close to the center on the original line of battalion commanders. (See figure 5-11.) The battalion commanders remain centered on their staffs. Company commanders oblique forward to close on a line four paces behind the line of battalion commanders (and staffs if directed). Guidon bearers oblique forward to close on a line four paces behind the line of company commanders. Platoon commanders oblique forward to close on a line four paces behind the line of guidon bearers. After officers center, while posting, the staff moves as a unit with their battalion commander.

f. During the march in review, if the parade is being conducted with companies in line formation and after the band has repositioned, the commander of the right battalion or independent company commands **"Right, FACE"** and **"Right Shoulder, ARMS,"** and column of threes is formed. Remaining battalions and independent companies form column of threes and come to right shoulder arms on commands from their respective commanders in succession from right to left. When all units are at right shoulder arms, the commander of the right unit commands **"Forward, MARCH."** The band steps off playing on this command. Commanders of succeeding units give similar commands to set their units in motion so as to follow at the prescribed distances.

g. During the march in review, if the companies are in mass formation and after the band has repositioned, the commander of the right battalion commands **"Right Shoulder, ARMS;"** and **"Column of Companies, Right Company, Right Turn, MARCH."** Should an independent company be on the right, its commander commands **"Right Shoulder, ARMS;"** and **"Right Turn, MARCH."** The band steps off playing with the right unit. Commanders of succeeding units give similar commands to set their units in motion so as to follow at the prescribed distances.

h. During the march in review, battalion commanders and their staffs initially march parallel to the line of troops and take position at the head of their battalions after the first change of direction. The commander of troops and the staff take position at the head of the band after the second change of direction. (See figure 5-12.)

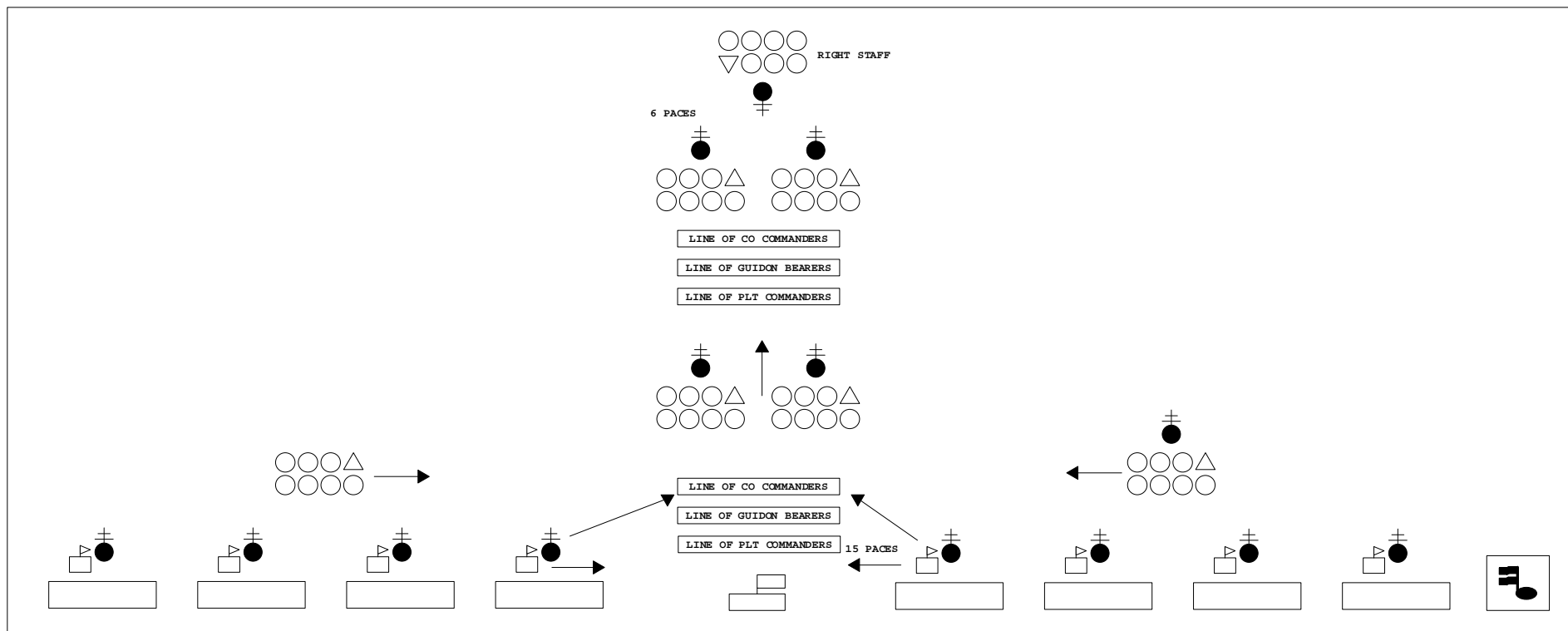

Figure 5-11.--Regimental Officers Center.

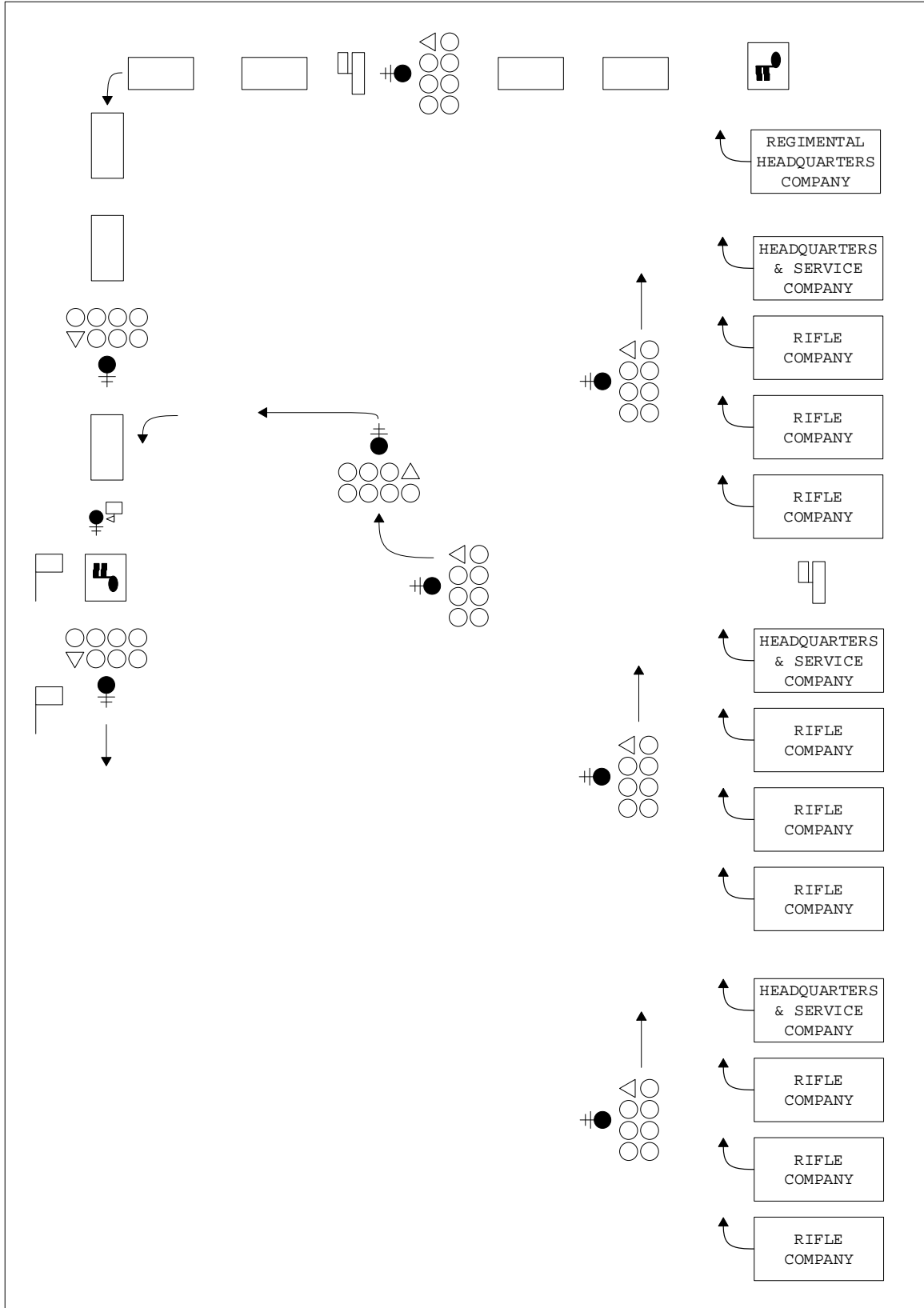

Figure 5-12.--Regimental March in Review.

i. Battalion commanders and their staffs execute eyes right in the same manner as the commander of troops and the staff. Companies march in review in mass formation, column of threes, or column of platoons in line executing changes in direction, flanking movements, and eyes right as appropriate in the same manner as in a battalion parade. After passing in review, only the regimental staff halts near the reviewing area and returns swords. The battalion commanders and their staffs continue to march down the line of march and lead their battalions from the parade field.

13. Battalion and Regimental Formations

a. For occasions in which a ceremony is desired, but the situation does not provide the opportunity or necessary space for maneuvering units as in a review or a parade, a battalion or regimental ceremonial formation may be conducted. One of several variations may be used according to the situation and type of ceremony desired.

b. One type of battalion (regimental) ceremonial formation is similar to that of a review except that the march in review is omitted. The battalion (regimental) commander acts as the reviewing officer, and the executive officer (or other officer so appointed) acts as the commander of troops. Basically, the battalion or regiment forms in line with companies in line or companies in mass formation at "*Adjutant's Call*" for the formation in the same manner as for a review.

(1) For a morning formation including Morning Colors, after the battalion (regiment) is presented to the commander of troops, the commander of troops commands "**SOUND ATTENTION.**" The band sounds "*Attention*". The Commander of troops then commands "**PRESENT ARMS.**" All persons in formation render appropriate salutes. The band then plays the "*National Anthem*" to which the colors are raised while the "*National Anthem*" is played. Immediately following the "*National Anthem*," the band plays "*Carry On.*"

(2) For an evening formation including "*Retreat*", after the battalion (regiment) is presented to the commander of troops, the commander of troops commands "**SOUND ATTENTION.**" The band sounds "*Attention*". The Commander of troops then commands "**PRESENT ARMS.**" All persons in formation render appropriate salutes. The band then plays the "*Retreat*" followed immediately by the "*National Anthem*" to which the colors are lowered while the "*National Anthem*" is played. Immediately following the "*National Anthem*," the band plays "*Carry On.*"

(3) After the command is presented to the commander of troops, if morning/ evening colors is not conducted, the commander of troops presents the command to the reviewing officer. If morning/evening colors are part of the ceremony, the commander of troops presents the command to the reviewing officer following the conduct of morning/evening colors.

(4) Presentation of decorations, promotions, retirements, etc., may then be conducted. The commander of troops then dismisses the battalion (regiment). The color guard and color company (battalion) return the colors.

c. Another type of formation is conducted in the same manner as a ceremonial parade, except that the march in review is omitted. The following additional modifications may be made:

(1) The band may "*Sound Off*" in-place, instead of marching. If

evening colors is part of the formation, "Retreat" is sounded after the band's second "Sound Off," and the adjutant brings the command to attention and to present arms. The flag is lowered while the "National Anthem" is played. For a formation at morning colors, the procedure is similar, except after the second "Sound Off," the band sounds "First Call," then the adjutant brings the command to attention and present arms for the flag to be raised while the "National Anthem" is played. After colors, the adjutant may bring the troops to order arms and then dismiss the command, or while troops are still at present arms following colors, the adjutant presents the command to the commander of troops.

(2) The commander of troops presents the command to the battalion (regimental) commander. Then decorations, promotions, retirements, etc., may be presented.

(3) On completion of the ceremony, the command is dismissed. The color guard and color company return the colors.

d. In any of the above ceremonial formations, the battalion (regimental) commander may act as both the commander of troops and the reviewing officer. In this case the following modifications are made:

(1) The adjutant presents the command to the battalion (regimental) commander after the troops are formed. The presentation normally made to the reviewing officer is omitted.

(2) During the presentation of decorations, promotions, retirements, etc., the adjutant performs those duties normally required of the commander of troops.

14. Street Parades

a. A person designated as the Grand Marshal commands street parades. The grand marshal appoints a chief of staff and aides, and issues an order concerning the formation, movement and dismissal of the parade. This order includes:

(1) The names of the staff officers and when and where they are to report to the marshal.

(2) The assignment of organizations and their order in battalions and larger units, and the names and assignment of battalion commanders and marshals of larger units.

(3) The streets upon which the battalions and larger units are to form, the direction their lines or columns face, where the right of line or head of column rests, and the width of the fronts of the subdivisions in column.

(4) The times for each unit to complete its forming and be ready to march.

(5) The time and place at, and from, which the head of the parade will move, the line of march and the direction of guide.

(6) Honors to be paid during the march.

(7) Instructions for dismissal of the parade.

(8) Instructions regarding uniform and equipment.

b. The grand marshal may review the parade at some point beyond the reviewing stand before it's dismissed.

c. The order of precedence of units in street parades involving two or more services of the United States or of a foreign nation are the same as prescribed in enclosure 2, chapter 3, paragraph 2. Veterans and patriotic organizations parade in the order prescribed by the grand marshal.

d. The grand marshal marches at the head of the parade. The staff, chief of staff on the right, marches one and a half (1 ½) paces to the rear in one or more ranks. Mounted police and a platoon of dismounted police who clear the way usually precede the grand marshal. The marshal of the first unit marches 24 paces to the rear of the staff of the grand marshal.

(1) Odd-numbered units are usually formed in streets to the right of the line of march, the first unit nearest the starting point. Even-numbered units are similarly formed on streets to the left of the line of march. Among formations which may be used for street parades are columns of threes (fours) abreast and mass formation. Transportation marches in single column or columns of twos, threes, or fours depending on the width of the street.

(2) In long parades, rifles may be carried at sling arms with fixed bayonets.

Chapter 6

Presentation of Decorations and Individual Retirement

TABLE OF CONTENTS

<u>IDENTIFICATION</u>	<u>TITLE</u>	<u>PAGE</u>
1.	General.....	6-2
2.	Formation.....	6-2
3.	Sequence of Events for the Presentation of Awards.	6-3
4.	Sequence of Events for Retirements.....	6-7
5.	Sequence of Events for Decorating Unit Colors.....	6-11
6.	Combined Ceremonies.....	6-13
7.	Battle Colors Ceremony.....	6-15
Figure 6-1	Positions of Retirees and Award Recipients.....	6-3
Figure 6-2	Precedence of Award Recipients.....	6-4
Figure 6-3	Commander of Troops Moves to get Colors and Award Recipients.....	6-4
Figure 6-4	Colors and Award Recipients Brought Forward.....	6-5
Figure 6-5	Posting the Colors and Award Recipients.....	6-7
Figure 6-6	Retirees Take their Posts.....	6-8
Figure 6-7	Precedence for Combined Awards and Retirement Ceremonies.....	6-14

Chapter 6

Presentation of Decorations and Individual Retirement

1. General

a. Ceremonies for the presentation of decorations and individual retirement shall be conducted as prescribed in this chapter. They will include the following:

- (1) The presentation of United States decorations.
- (2) The decoration of organizational colors.
- (3) The presentation of foreign decorations.
- (4) The re-dedication of a unit's battle colors.
- (5) The retirement of an individual or a group of any rank.

(6) Throughout this chapter, the term "sergeant major" will be used to reflect the actual billet of the unit sergeant major, or the senior enlisted representative present.

b. When practicable, the ceremony set forth below will be held when presenting individual and unit awards and decorations or upon retirement of individuals. The ceremony may be as simple as a formation of the unit affected, a review or a parade depending on the desires of the commander.

2. Formation

a. The command is formed for the appropriate ceremony (e.g., unit formation, parade or review) per this Manual.

b. The color guard is not trooped, but marches on with the formation since the colors are brought forward for the ceremony.

c. Marines, Sailors and other service members receiving awards and decorations are formed as the last rank of the company to the color guard's left and march on with the unit. (See figure 6-1). They fall in according the rank of the decoration to be conferred, the highest ranking decoration on the right.

d. Marines, Sailors and other service members who are retiring sit in the reviewing stand with their families, since this parade is being held in their honor. (See figure 6-1.) When the time comes to effect their retirement, the retirees form to the left of the reviewing stand in a column, from front to rear as listed below, so that they are arranged by seniority, from right to left, when presented to the reviewing officer. They march on when the colors have halted and prior to the commander of troops reporting **"Marine, officer, or personnel to be Retired All Present."** (See figure 6-5.)

(1) Junior retiree, by grade, not receiving an award to senior retiree, by grade, not receiving an award.

- (2) Junior retiree, by grade, by award, not by rank for award only.

e. The sequence for the presentation of awards, effecting retirements and battle colors re-dedication begins after the commander of troops has presented the command to the unit commander and the command is back at order arms if a parade, or after trooping the line if a review. The commander of troops, having placed the command at attention and order arms, faces the reviewing area. Seeing that the reviewing officer is in position, the commander of troops faces the command and begins the sequence of events to present awards per paragraph 3, effect retirements per paragraph 4, to decorate unit colors per paragraph 5, conduct a combined ceremony per paragraph 6, or re-dedicate a units battle colors per paragraph 7.

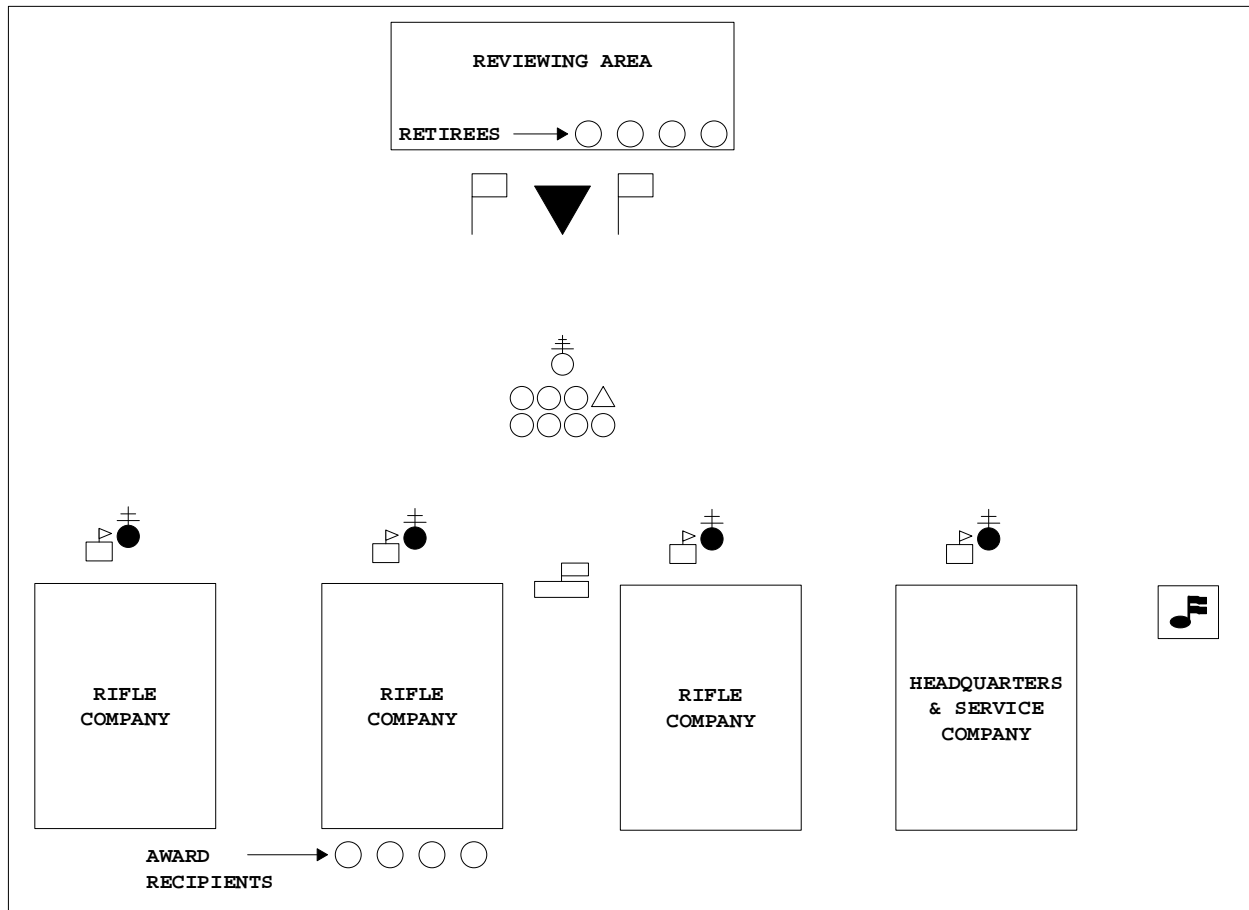

Figure 6-1.--Positions of Retirees and Award Recipients.

3. Sequence of Events for the Presentation of Awards

a. Commander of troops commands **"Marine, officer, or personnel to be Decorated and All Colors, Center, MARCH."** On the command **"Colors,"** the color guard goes to carry colors and the staff goes to carry sword.

(1) On the command **"Center,"** person(s) to receive awards and the staff execute a right face.

(2) On the command **"MARCH,"** the staff steps of and moves forward approximately 8-10 paces, halts, executes a left face, without command.

(3) The award recipients step off and march to a position approximately five paces in front of and centered on the colors. (See figure 6-2.)

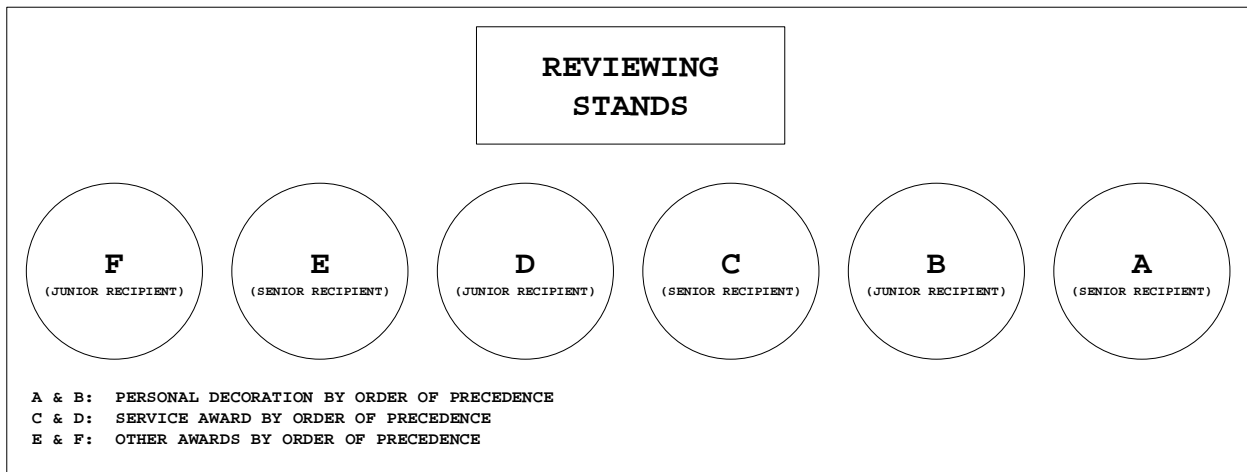

Figure 6-2.--Precedence of Award Recipients.

(4) The commander of troops, once the staff has cleared, marches forward to the line of award recipients, halts 5-10 paces in front of them, salutes the colors, and faces about. (See figure 6-3.)

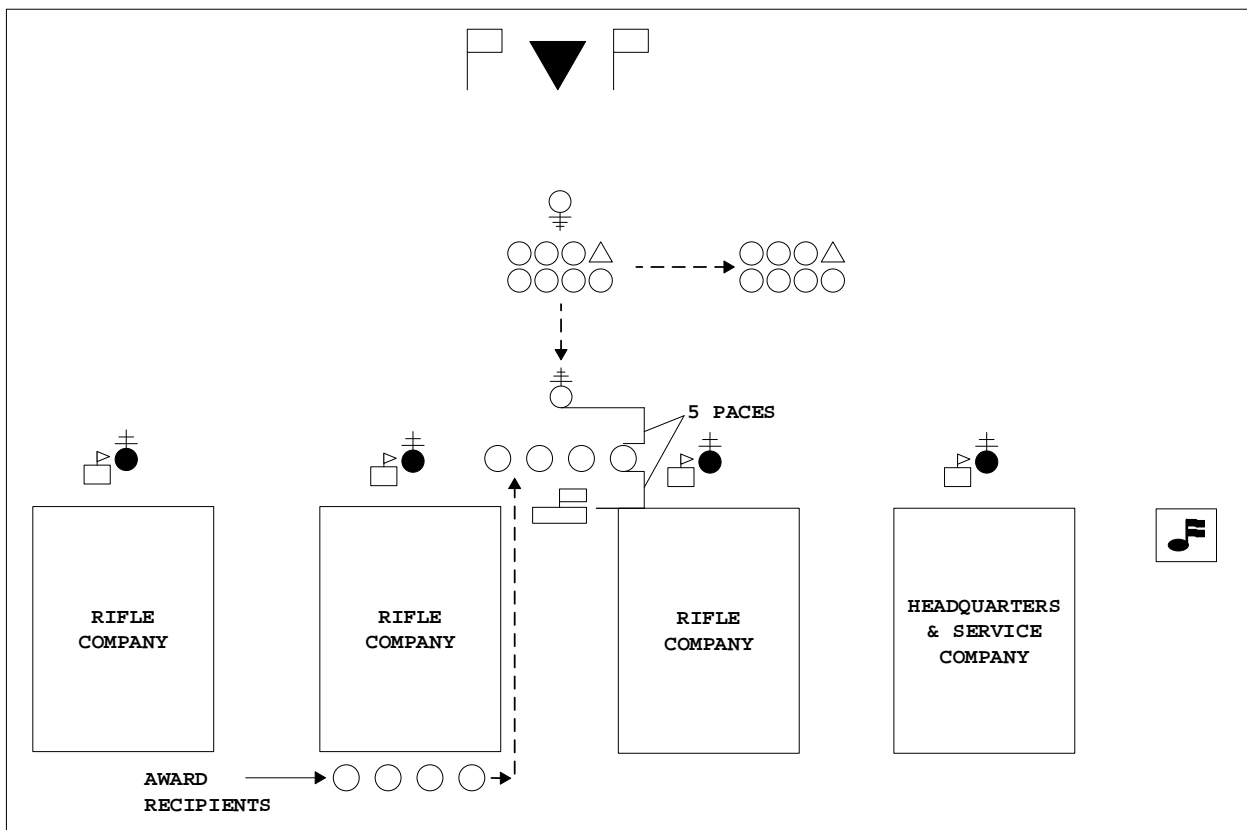

Figure 6-3.--Commander of Troops Moves to Get Colors and Award Recipients.

b. Commander of troops commands **"Forward, MARCH."**

(1) The commander of troops, award recipients and color guard march forward towards the reviewing area. The commander of troops commands **"Detachment, HALT"** so that the detail is halted with the commander of troops approximately 8-10 paces in front of and centered on the reviewing officer. (See figure 6-4.) The color guard remains at the carry.

(2) The adjutant commands the staff to left face and marches the staff back to its position, where the staff halts, faces the reviewing area and goes to order sword on command of the adjutant. The commander of troops then salutes the reviewing officer and reports, **"Sir/Ma'am, Marine, officer, or personnel to be Decorated and All Colors are Present."** The commander returns the commander of troops' salute.

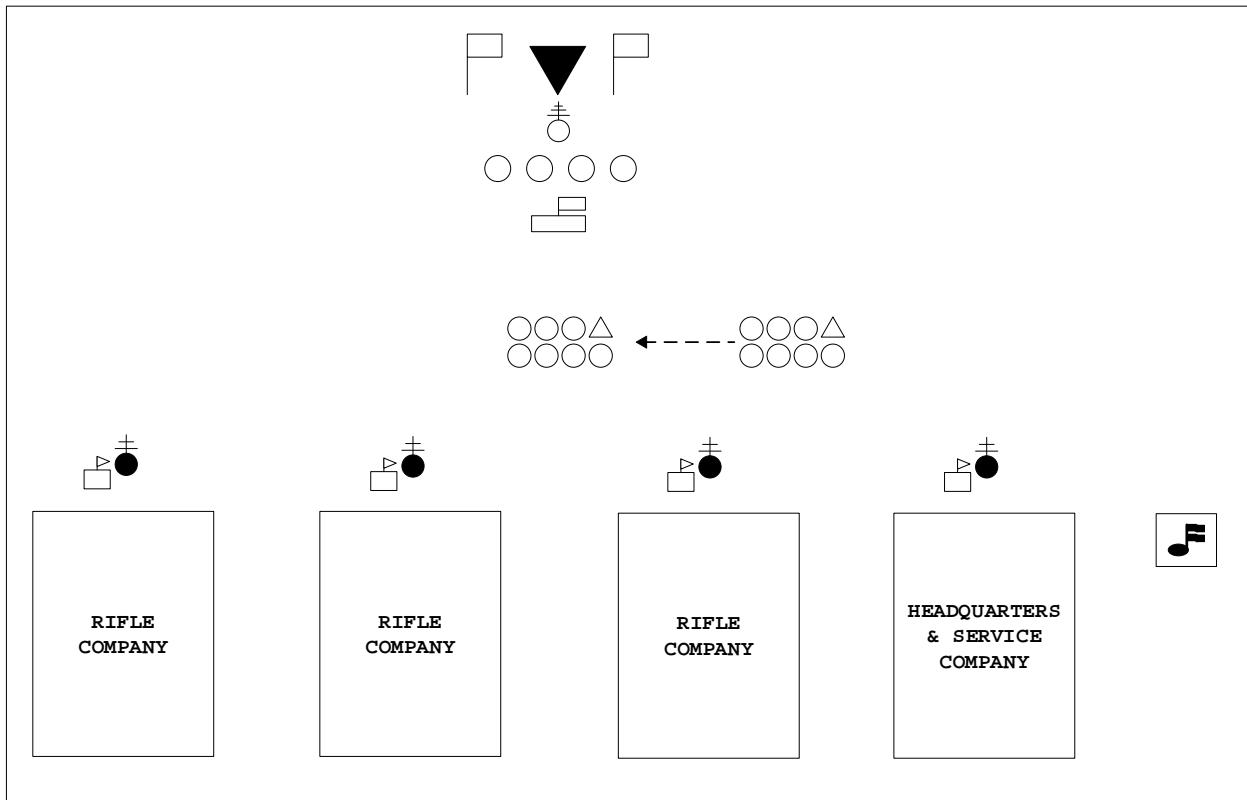

Figure 6-4.--Colors and Award Recipients Brought Forward.

c. Reviewing Officer commands **"PRESENT THE COMMAND."** The commander of troops returns to the carry, steps right as in marching and moves to a position in front of the staff, saluting the colors as the Marine passes them, halts facing the line of troops.

d. Commander of troops commands **"Present, ARMS."** The unit executes. The commander of troops faces the reviewing area.

e. Commander of troops then commands **"Staff, Present, ARMS."** The commander of troops and staff execute present arms.

NARRATOR: "LADIES AND GENTLEMEN, PLEASE RISE FOR THE PRESENTATION OF COLORS AND REMAIN STANDING FOR THE PRESENTATION OF THE AWARD."

(1) The color guard riflemen execute present arms from the carry upon command of the staff.

(2) On the first note of the "*National Anthem*" or "*To The Colors*," the award recipients and reviewing officer executes a hand salute, and the organizational color bearer presents colors.

(3) After the last note of the "*National Anthem*" or "*To The Colors*," the organizational color bearer returns to the carry position. The award recipients and reviewing officer terminate their salute.

f. Commander of troops commands "**Staff, Order, SWORD.**" The commander of troops, staff, and color guard go to the order. The commander of troops then goes to carry sword and faces the line of troops.

g. Commander of troops commands "**Order, ARMS.**" The unit executes. The commander of troops then faces the reviewing area and goes to order sword.

h. The reviewing officer, assisted by the sergeant major now moves forward and presents the awards. As the reviewing officer arrives in front of each award recipient, the narrator reads the award citation and the reviewing officer attaches the medal over the left breast pocket of the recipient.

(1) When the medal is attached, the reviewing officer and recipient shake hands. Immediately after shaking hands, the award recipient salutes the reviewing officer, who returns the salute.

(2) The reviewing officer then moves to the next award recipient by stepping to the left as in marching, taking approximately one and a half (1 ½) steps, halts and faces the next recipient.

(3) After the last award is presented, the reviewing officer moves back to the reviewing area and the sergeant major departs the field.

NOTE: Immediately after the award(s) presentation is complete, the narrator will state the following:

NARRATOR: "LADIES AND GENTLEMEN, PLEASE BE SEATED."

i. Commander of troops commands "**Staff, Carry, SWORD**" and "**POST THE COLORS.**" The commander of troops and staff execute carry swords. The color guard executes carry colors on command from the color sergeant.

j. Commander of troops commands "**Staff, Right, FACE**" and "**Staff, Forward, MARCH.**" The commander of troops and staff execute.

(1) Color guard executes a countermarch and moves back to its position in formation, countermarches, halts and goes to order colors.

(See figure 6-5.)

(2) The commander of troops and staff march forward, per enclosure 2, chapter 2, paragraph 4.d., sufficiently for the colors to pass, halts, and executes a left face. When the colors have passed, the commander of troops moves the staff back to its position, halts and executes a right face and goes to order sword on command of commander of troops. However, the commander of troops faces the line of troops, remaining at carry sword. When the color guard is in position, and at order colors, the commander of troops faces the reviewing area. (See figure 6-5.)

(3) The award recipients march to their position in the reviewing area, and form a line at normal interval, to the left of the reviewing officer. (See figure 6-5.)

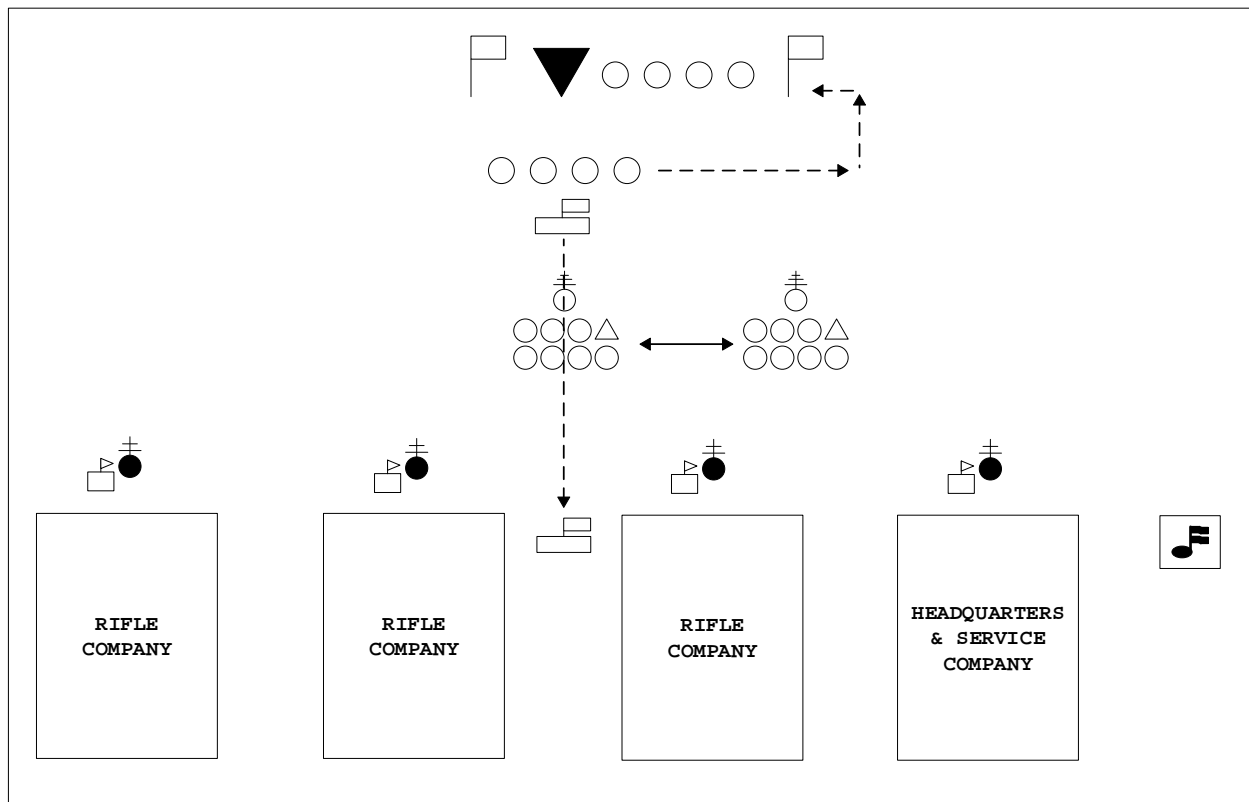

Figure 6-5.--Posting the Colors and Award Recipients

k. The ceremony would then continue as prescribed for a review (see enclosure 2, chapter 4), parade (see enclosure 2, chapter 5) or unit formation. (e.g., the command be marched in review, dismissed, etc.)

4. Sequence of Events for Retirements

a. After the command has been presented to the reviewing officer, and while the commander of troops is giving the command of "Order, ARMS," the retirees form to the left of the reviewing stand. The retirees form in a single file at twice the normal distance so that they will be extended interval when halted in front of the reviewing officer. This allows space for their spouses to stand at their left. They march on in reverse order.

(See figure 6-6.)

b. Commander of troops commands **"Marine, officer, or personnel to be Retired and All Colors, Center, MARCH."** On the command **"Colors,"** the color guard goes to carry colors, and the staff goes to carry sword.

(1) On the command **"Center,"** the staff executes a right face.

(2) On the command **"MARCH,"** the staff steps off and moves forward approximately 8-10 paces, halts, and executes a left face without command.

(3) The commander of troops, once the staff has cleared, marches forward to the color guard, halts 5-10 paces in front of them, salutes the colors, and faces about.

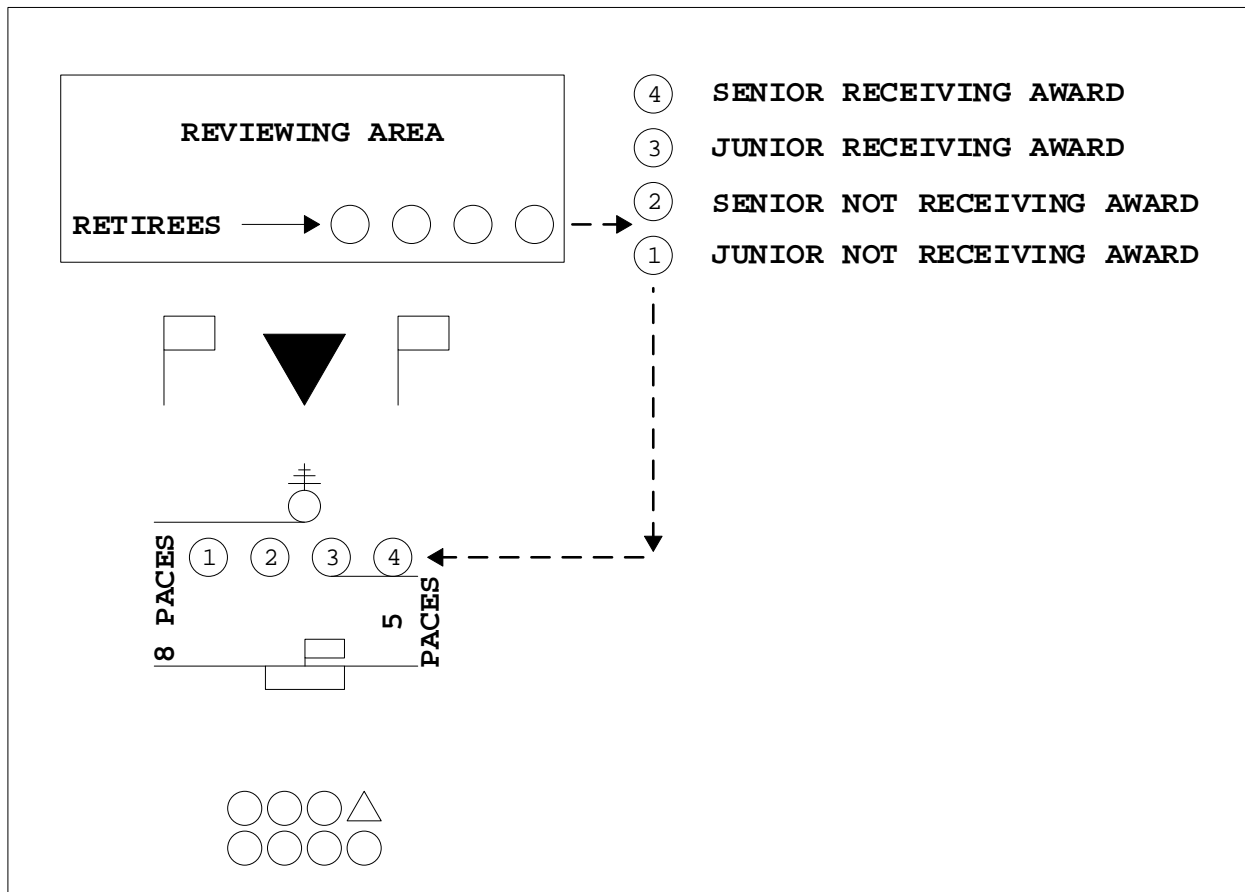

Figure 6-6.--Retirees take Their Posts.

c. Commander of troops commands **"Forward, MARCH."** The commander of troops and color guard march forward towards the reviewing area. The commander of troops commands **"Detachment, HALT"** so that the detail is halted with the commander of troops approximately 8-10 paces in front of and centered on the reviewing officer. (See figure 6-3.) The color guard remains at the carry.

(1) The adjutant commands left face and marches the staff back to its position, where the staff halts, faces the reviewing area without

command and goes to order sword on the command of the Adjutant.

(2) The retirees march forward, execute a column right, march to a position five paces in front of the color guard, halt and execute a right face. They will be at extended interval.

(3) The commander of troops, once the retirees are in position, salutes the reviewing officer and reports **"Sir/Ma'am, Marine, officer, or personnel to be Retired and All Colors are Present."** The reviewing officer returns the commander of troops' salute.

d. Reviewing officer commands **"PRESENT THE COMMAND."** The commander of troops returns to the carry, steps right in marching and moves to a position in front of the staff, saluting the colors as he/she passes them, and halts facing the line of troops.

e. Commander of troops commands **"Present, ARMS."** The unit executes. The commander of troops faces the reviewing area.

f. Commander of troops then commands **"Staff, Present, ARMS."** The commander of troops and staff execute present sword.

NARRATOR: "LADIES AND GENTLEMEN, PLEASE RISE FOR THE PRESENTATION OF COLORS."
--

(1) The color guard riflemen execute present arms on the command of the staff, from the carry.

(2) On the first note of the "*National Anthem*" or "*To The Colors*," the retirees and reviewing officer executes a hand salute and the organizational color bearer presents colors.

(3) After the last note of the "*National Anthem*" or "*To The Colors*," the organizational color bearer returns to the carry position. The retirees and reviewing officer terminates their salute.

g. Commander of troops commands **"Staff, Order, SWORD."** The commander of troops, staff, and color guard go to the order. The commander of troops then goes to carry sword and faces the line of troops.

h. Commander of troops commands **"Order, ARMS."** The unit executes. The commander of troops then faces the reviewing area and goes to order sword.

i. The reviewing officer, assisted by the sergeant major now moves forward and presents the awards, if any, and effects the retirements.

(1) As the reviewing officer arrives in front of each retiree, the narrator reads the award citation, if any, and the reviewing officer attaches the medal over the left breast pocket of the recipient.

NARRATOR: "LADIES AND GENTLEMEN, PLEASE BE SEATED"

(2) The narrator then reads extracts from the retirement orders, (e.g., Transferred to the retired list (FMCR) after 20 years of service, Date

of retirement, etc.) At this time, each retiree is presented a national flag.

(3) The reviewing officer then moves to the next retiree by stepping to the left in marching, taking approximately one and a half (1 ½) steps, halts and faces the next recipient. After the last retirement has been effected, the reviewing officer moves back to the reviewing area and the sergeant major departs the field. (If spouses are to be recognized the sergeant major will remain and assist the reviewing officer). If spouses are not recognized, the reviewing officer followed by the retirees may make remarks.

j. Once the last retirement order is read and if there will be recognition of the spouses and remarks by the reviewing officer and retirees, the commander of troops will come to the carry, face about and order parade rest. The commander of troops will then face about and give the staff parade rest. If any additional letters are to be read (letter from the President of the United States, Commandant of the Marine Corps, or Sergeant Major of the Marine Corps), it will happen after the command is at parade rest, and before recognition of the spouse.

k. Marines assigned to do so, now escort the spouses of the retirees to the left of their spouse, and stand behind the spouse they escorted.

(1) The narrator then reads the spouse's citation (Optional).

(2) After all spouses have been recognized, the Marines assigned as escorts will return the spouses to their seats.

(3) At this time, the reviewing officer moves back to the reviewing area and the sergeant major departs the field. The reviewing officer followed by the retirees may make remarks at this time.

(4) Once all remarks have been made, the reviewing officer returns to the designated position in the reviewing area.

(5) The commander of troops, seeing the reviewing officer back in position, comes to attention, and goes to carry sword.

l. Commander of troops commands "**Staff, ATTENTION,**" faces about and commands "**(Size of Unit), ATTENTION.**" Commander of troops faces about and commands "**POST THE COLORS**" and "**Staff, Carry, SWORD.**" The commander of troops and staff execute carry swords. The color guard executes carry colors.

m. Commander of troops commands "**Staff, Right, FACE**" and "**Staff, Forward, MARCH.**" The commander of troops and staff execute.

(1) Color guard executes a countermarch and moves back to its position in formation, countermarches, halts and goes to order color. (See figure 6-5.)

(2) The commander of troops and staff march forward sufficiently as prescribed in enclosure 2, chapter 2, paragraph 4.d.(3) through 4.d.(6) for the colors to pass, halts, does a left face and remains at carry sword. When the colors have passed, the commander of troops moves the staff back to its position, halts and executes a right face without command and goes to order sword by command of the commander of troops. However, the commander

of troops faces the line of troops, remaining at carry sword. When the color guard is in position, and at order colors, the commander of troops faces the reviewing area. (See figure 6-5.)

(3) The retirees on command of the commander of troops march to their position in the reviewing area, and form a line at normal interval, to the left of the reviewing officer. (See figure 6-5.)

n. The ceremony would then continue as prescribed for a review (see enclosure 2, chapter 4), a parade (see enclosure 2, chapter 5) or unit formation. (e.g., the command be marched in review, dismissed, etc.)

o. Any additional events not covered in this chapter should not take place during the ceremony.

5. Sequence of Events for Decorating Unit Colors

a. Commander of troops commands **"All Colors, Center, MARCH."** On the command **"Colors,"** the color guard goes to carry colors and the staff goes to carry sword.

(1) On the command **"Center,"** the staff executes a right face.

(2) On the command **"MARCH,"** the staff steps off and moves forward approximately 8-10 paces, as prescribed in enclosure 2, chapter 2, paragraph 4.d.(3) through 4.d.(6), halts, executes a left face without command and remains at the carry sword.

(3) The colors being decorated step off and march to a position 5-10 paces in front of and centered on the color guard.

Note: This portion of the movement is only if the units receiving unit awards are subordinate to the parade unit (e.g., battalion colors being decorated at a regimental parade. If the unit hosting the parade is also the unit receiving the award, then the unit colors remains in the color guard.

(4) The commander of troops, once the staff has cleared, marches forward to the line of organizational colors, halts approximately 5-10 paces in front of them, salutes the colors, and faces about.

b. Commander of troops commands **"Forward, MARCH."**

(1) The commander of troops, award recipients and color guard march forward towards the reviewing area. The commander of troops commands **"Detachment, HALT"** so that the detail is halted with the commander of troops approximately 5-10 paces in front of and centered on the reviewing officer. (See figure 6-4.) The color guard remains at the carry.

(2) The adjutant commands the staff to left face and marches the staff back to its position, where the staff halts without command, faces the reviewing area and goes to order sword by command of the adjutant. The commander of troops then salutes the reviewing officer and reports, **"Sir/Ma'am, All Colors are Present."** The reviewing officer returns the commander of troops' salute.

c. Reviewing officer commands, **"PRESENT THE COMMAND."** The commander of

troops returns to the carry, steps right as in marching and moves to a position in front of the staff, saluting the colors as he/she passes them, and halts facing the line of troops.

NARRATOR: "LADIES AND GENTLEMEN, PLEASE RISE FOR THE PRESENTATION OF COLORS."

d. Commander of troops commands **"Present, ARMS."** The unit executes. The commander of troops faces the reviewing area.

e. Commander of troops then commands **"Staff, Present, ARMS."** The commander of troops and staff execute present arms.

(1) The color guard riflemen execute present arms on the command of the staff, from the carry.

(2) On the first note of the *"National Anthem"* or *"To The Colors,"* the reviewing officer executes a hand salute and the organizational color bearer, and colors being decorated, present colors.

(3) After the last note of the *"National Anthem"* or *"To The Colors,"* the organizational color bearer returns to the carry position. The reviewing officer terminates their salute.

f. Commander of troops commands **"Staff, Order, SWORD."** The commander of troops and staff, go to the order. The color guard returns to the carry. The commander of troops then goes to carry sword and faces the line of troops and commands.

g. Commander of troops commands **"Order, ARMS."** The unit executes. The commander of troops then faces the reviewing area and goes to order sword.

NARRATOR: "LADIES AND GENTLEMEN, PLEASE BE SEATED."

h. The reviewing officer, unit commander(s) and sergeant major now move forward to present the awards. As the reviewing officer arrives in front of the colors being decorated, the narrator reads the award citation.

(1) The organizational color bearer dips the colors forward sufficiently, without the colors touching the ground, to allow the reviewing officer to reach the streamer attachment set. The reviewing officer then attaches the streamer to the colors.

(2) The reviewing officer then moves to the next colors by stepping to the left as in marching, taking approximately one and a half (1 ½) steps, halts and faces the colors.

(3) After the streamer is attached, the reviewing officer and unit commander moves back to the reviewing area and the sergeant major departs the field.

(4) Remarks if desired are made. If remarks are to be made, the commander of troops will place the unit and staff at parade rest. After

remarks are completed and the reviewing officer is back in the designated position, the commander of troops will bring the staff and the unit back to attention.

(5) If no remarks are made, the commander of troops, seeing the reviewing officer back in position, goes to carry sword.

i. Commander of troops commands "**POST THE COLORS**" and "**Staff, Carry, SWORD.**" The commander of troops and staff execute carry swords.

j. Commander of troops commands "**Staff, Right, FACE**" and "**Staff, Forward, MARCH.**" The commander of troops and staff execute.

(1) Color guard executes a countermarch and moves back to its position in formation, countermarches, halts and goes to order colors. (See figure 6-5.)

(2) The commander of troops and staff march forward, sufficiently for the colors to pass, halts, does a left face without command and remains at carry sword. When the colors have passed the commander of troops moves the staff back to its position, halts and executes a right face without command and goes to order sword by command of the commander of troops. However, the commander of troops faces the line of troops, remaining at carry sword. When the color guard is in position, and at order colors, the commander of troops faces the reviewing area. (See figure 6-5.)

k. The ceremony would then continue as prescribed for a review (see enclosure 2, chapter 4), a parade (see enclosure 2, chapter 5) or unit formation. (e.g., the command be marched in review, dismissed, etc.)

6. Combined Ceremonies

a. On occasion, it will be necessary to combine retirements, awarding personal decorations and unit awards in one ceremony. The ceremony would follow the sequence in paragraph 3, with the following exceptions.

(1) Award recipients and retirees either form behind the company to the left of the color guard, or in the reviewing stand. (See figure 6-1.) If personnel are marching from both locations, the unit leader will coordinate in advance how they will march on and position themselves in front of the reviewing officer.

(2) In order to bring forward the award recipients and retirees the commander of troops commands "**Marine, officer, or personnel to be Decorated, Retired and All Colors, Center, MARCH.**" When reporting to the reviewing officer the commander reports, "**Sir/ Ma'am, Marine, officer, or personnel to be Decorated, Retired and All Colors are Present.**"

(3) Spouses of retirees are not brought forward.

(4) The formation for the colors receiving awards, person(s) being decorated and retired is depicted in figure 6-7. In those circumstances where an individual is both receiving a decoration and retiring, the Marine would be placed in the line by the precedence of the decoration. In this case, the decoration is presented and the retirement is effected prior to moving to the next individual in rank. Use the following precedence for

individuals as an example.

- (a) Unit decoration in order of precedence.
- (b) Individual receiving a decoration in order of precedence and retiring.
- (c) Individual receiving a decoration in order of precedence.
- (d) Senior individual retiring with no decoration.
- (e) Junior individual retiring with no decoration.

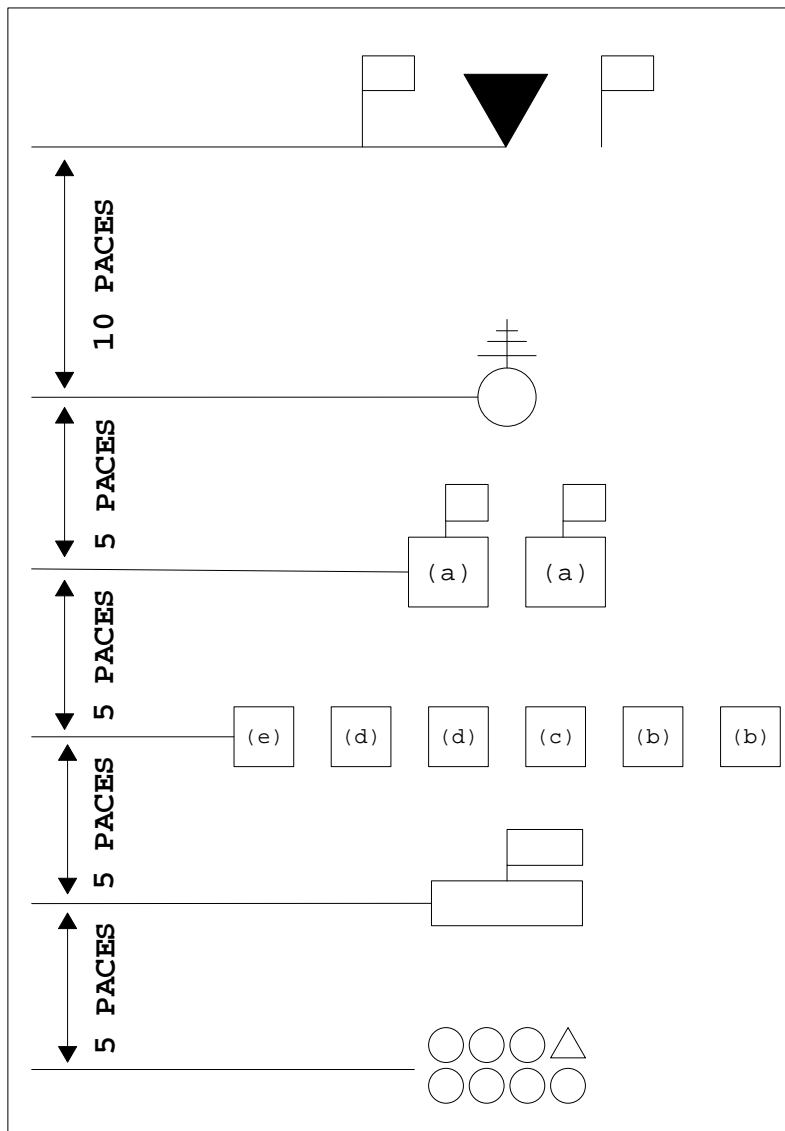

Figure 6-7.--Precedence for Combined Awards and Retirement Ceremonies.

b. The reviewing officer first awards the unit decoration, then the individual decorations and retirements.

c. When posting the colors, the unit colors receiving awards do not march forward until the person(s) receiving individual decorations and retiring have cleared their path. The award recipients and retirees march to their position in the reviewing area, and form a line at normal interval, to the left of the reviewing officer. (See figure 6-5.)

Note: Personnel in key billets who are called forward to receive an award will return to their position in formation once the award recipients have posted to the left of the reviewing officer.

7. Battle Colors Ceremony

a. This ceremony follows almost exactly the same sequence used for decorating colors in paragraph 5. The difference is that it is designed to re-dedicate a unit's organizational colors. This is normally done when celebrating a unit's anniversary or when commemorating a specific battle in which the unit participated.

(1) Prior to the start of the ceremony when the colors are being delivered to the color guard, the individual streamers designating the units honors are removed from the organizational colors streamer attachment set.

(2) Each streamer is given to a designated Marine who will deliver the streamer to the reviewing officer during the presentation portion of the ceremony.

(3) Person(s) designated to deliver the streamers will form up in the same manner as retirees per paragraph 4.a. as shown in figure 6-6. They fall in chronological order of issuance, the oldest streamer presented at the front.

b. Commander of troops commands **"Colors to be Re-dedicated and All Colors, Center, MARCH."**

(1) On the command **"Colors,"** the color guard goes to carry colors and the staff goes to carry sword.

(2) On the command **"Center,"** the staff executes a right face.

(3) On the command **"MARCH,"** the staff steps off and moves forward approximately 8-10 paces, halts, executes a left face without command remains at carry sword.

(4) The commander of troops, once the staff has cleared, marches forward to the color guard, halts approximately 5-10 paces in front of them, salutes the colors, and faces about.

c. Commander of troops commands **"Forward, MARCH."**

(1) The commander of troops and color guard march forward towards the reviewing area. The commander of troops commands **"Detachment, HALT"** so that the detail is halted with the commander of troops approximately 5-10 paces in front of and centered on the reviewing officer. The color guard remains at the carry.

(2) The adjutant commands the staff to left face and marches the

staff back to its position, where the staff halts, faces the reviewing area without command and goes to order sword by command of the adjutant. The commander of troops then salutes the reviewing officer and reports, **"Sir/Ma'am, Colors to be Re-dedicated and All Colors are Present."** The reviewing officer returns the commander of troops' salute.

d. Reviewing officer commands, **"PRESENT THE COMMAND."** The commander of troops returns to the carry, steps right as in marching and moves to a position in front of the staff, saluting the colors as he/she passes them, and halts facing the line of troops.

e. Commander of troops commands **"Present, ARMS."** The unit executes. The commander of troops faces the reviewing area.

NARRATOR: "LADIES AND GENTLEMEN, PLEASE RISE FOR THE PRESENTATION OF COLORS."
--

f. Commander of troops then commands **"Staff, Present, ARMS."** The commander of troops and staff execute present sword.

(1) The color guard riflemen execute present arms, from the carry.

(2) On the first note of the *"National Anthem"* or *"To The Colors,"* the reviewing officer executes a hand salute and the organizational color bearer presents colors.

(3) After the last note of the *"National Anthem"* or *"To The Colors,"* the organizational color bearer returns to the carry position. The reviewing officer terminates their salute.

g. Commander of troops commands **"Staff, Order, ARMS."** The commander of troops, staff, and color guard go to the order. The commander of troops then goes to carry sword, and faces the line of troops.

NARRATOR: "LADIES AND GENTLEMEN, PLEASE BE SEATED."
--

h. Commander of troops commands **"Order, ARMS."** The unit executes. The commander of troops then faces the reviewing area and goes to order sword.

i. The reviewing officer assisted by the sergeant major now moves forward to re-attach the streamers. The organizational color bearer dips the colors forward sufficiently, without the colors touching the ground, to allow the reviewing officer to reach the streamer attachment set. The reviewing officer then attaches each streamer to the colors as the narrator reads the citation for the streamer.

(1) As the citation for each streamer is read the designated person(s) with that streamer will march forward and present the streamer to the reviewing officer. Once the streamer is attached, this person(s) will leave the reviewing area and move behind the reviewing stands.

(2) Once all streamers are re-attached, the ceremony will proceed in the same manner as those outlined in paragraph 5.

Chapter 7

Change of Command Ceremony

TABLE OF CONTENTS

<u>IDENTIFICATION</u>	<u>TITLE</u>	<u>PAGE</u>
1.	General.....	7-2
2.	Occasion.....	7-2
3.	Formation.....	7-2
4.	Sequence of Events for a Change of Command without Promotion, Retirement or Awards.....	7-2
5.	Sequence of Events for a Change of Command with Promotion.....	7-6
6.	Sequence of Events for a Change of Command with Presentation of Awards and/or Retirement.....	7-7
7.	Honors for General Officers and High Ranking Civilians Participating in the Change of Command..	7-9
Figure 7-1	Delivering and Returning the Colors.....	7-4

Chapter 7

Change of Command Ceremony

1. General. Changes of command in the Marine Corps shall be conducted as prescribed in this Chapter. (The term "sergeant major" will reflect either the unit sergeant major or senior enlisted representative present.)

2. Occasion. When practicable, the ceremony set forth below will be held upon the change of command for an organization of battalion or squadron size, or larger units and directors of schools. The ceremony is normally a parade (see enclosure 2, chapter 5), however, it may be a review or as simple as a formation of the unit affected.

3. Formation

a. The command is formed for the appropriate ceremony (e.g., unit formation, review or parade) per enclosure 2, chapters 4 and 5. When the selected ceremony reaches the point in time when the command is presented to the outgoing commander, the sequence of events for the change of command as outlined in this Chapter will be followed.

b. The color guard is normally trooped as part of the sequence of events. However, if the incoming commander is being promoted at the parade or the outgoing commander is retiring or receiving an award during the parade, the color guard marches on with the formation and the colors are brought forward for the promotion/retirement/awards portion of the ceremony.

4. Sequence of Events for a Change of Command without Promotion, Retirement or Awards

a. The standard sequence for a change of command normally begins after the commander of troops has presented the command to the outgoing commander. On occasion, modifications to the normal sequence can take place, such as:

- (1) The playing of "*Honors*," (or)
- (2) "*Trooping the Line*" during a Review.

Note: In these cases, the commander of troops presents the command after completion of the scenarios described above.

b. The commander of troops, having placed the command at attention and order arms, faces the reviewing area. The incoming commander then takes the designated post in the reviewing area to the left and abreast of the outgoing commander. (See figure 7-1.)

c. Commander of troops commands **"Sergeant Major, Deliver the Colors to the Commanding Officer (General)."**

NARRATOR: LADIES AND GENTLEMEN, WE NOW COME TO THE CEREMONY'S MOST SOLEMN MOMENT, THE ACTUAL PASSING OF COMMAND. THE BATTLE COLORS OF A MARINE CORPS UNIT SYMBOLIZE THE AUTHORITY AND ACCOUNTABILITY OF COMMAND. TRANSFERRING THE COLORS DURING THE CEREMONY SYMBOLIZES THE RELINQUISHING OF COMMAND BY _____, AND BY ACCEPTING THE COLORS, _____ ACCEPTS COMMAND AND CONFIRMS HIS/HER TOTAL COMMITMENT TO THE MARINES AND SAILORS THAT HE/SHE WILL COMMAND. SERGEANT MAJOR _____ IS DELIVERING THE COLORS TO THE COMMANDING OFFICER (GENERAL)."

d. The sergeant major, who is positioned to the left of the reviewing area, moves by the most direct route to the color guard, passing the commander of troops and staff on his/her own right.

(1) Upon the commander of troop's command to the sergeant major, the color guard executes carry colors.

(2) The sergeant major halts one pace in front of and centered on the color guard, and salutes the national colors. Once rendered, he/she then takes one right step, while at the same time the organizational color bearer removes the organizational colors from the socket. The sergeant major grasps the organizational colors, (left hand at the base near the ferrule, right hand on the staff approximately eye level) and steps off to the right as in marching.

(3) The color guard remains at carry colors until the organizational colors is returned.

(4) The sergeant major then marches to the reviewing area carrying the colors as close to the "carry colors" position as possible without a sling. The sergeant major passes the commander of troops and staff on his/her own right. The sergeant major halts approximately two paces in front of the outgoing commander. (See figure 7-1.)

e. Commander of troops commands **"Present, ARMS,"** as the sergeant major is approaching the staff. The commander of troops then faces the reviewing area.

f. Commander of troops commands **"Staff, Present, SWORD."**

(1) The staff executes. At this time, the narrator will read the orders of the outgoing commander. The sergeant major then delivers the colors to the outgoing commander (the colors remaining in its most upright position), then executes one right step and salutes.

(2) On the sergeant major's salute, the outgoing and incoming commanders face each other. At this time, the narrator will read the orders of the incoming commander. The outgoing commander passes the colors to the incoming commander.

(3) Both commanders then face front. The sergeant major cuts his/her salute and executes one right step. The incoming commander then returns the colors to the sergeant major.

(4) The outgoing and incoming commanders then face each other, exchange salutes and handshakes, and exchange positions (right shoulder to right shoulder).

(5) The sergeant major then steps off to the right as in marching and returns the colors to the color guard, passing the staff on his/her right. When arriving at the color guard, the sergeant major halts centered on the color guard and returns the organizational colors. The sergeant major salutes, steps to the right as in marching, and moves by the most direct route from the field, passing the staff on his/her own right. (See figure 7-1.)

g. Commander of troops commands **"Staff, Order, SWORD,"** as the sergeant major is moving to return the organizational colors. The commander of troops and staff execute. The commander of troops faces the line of troops.

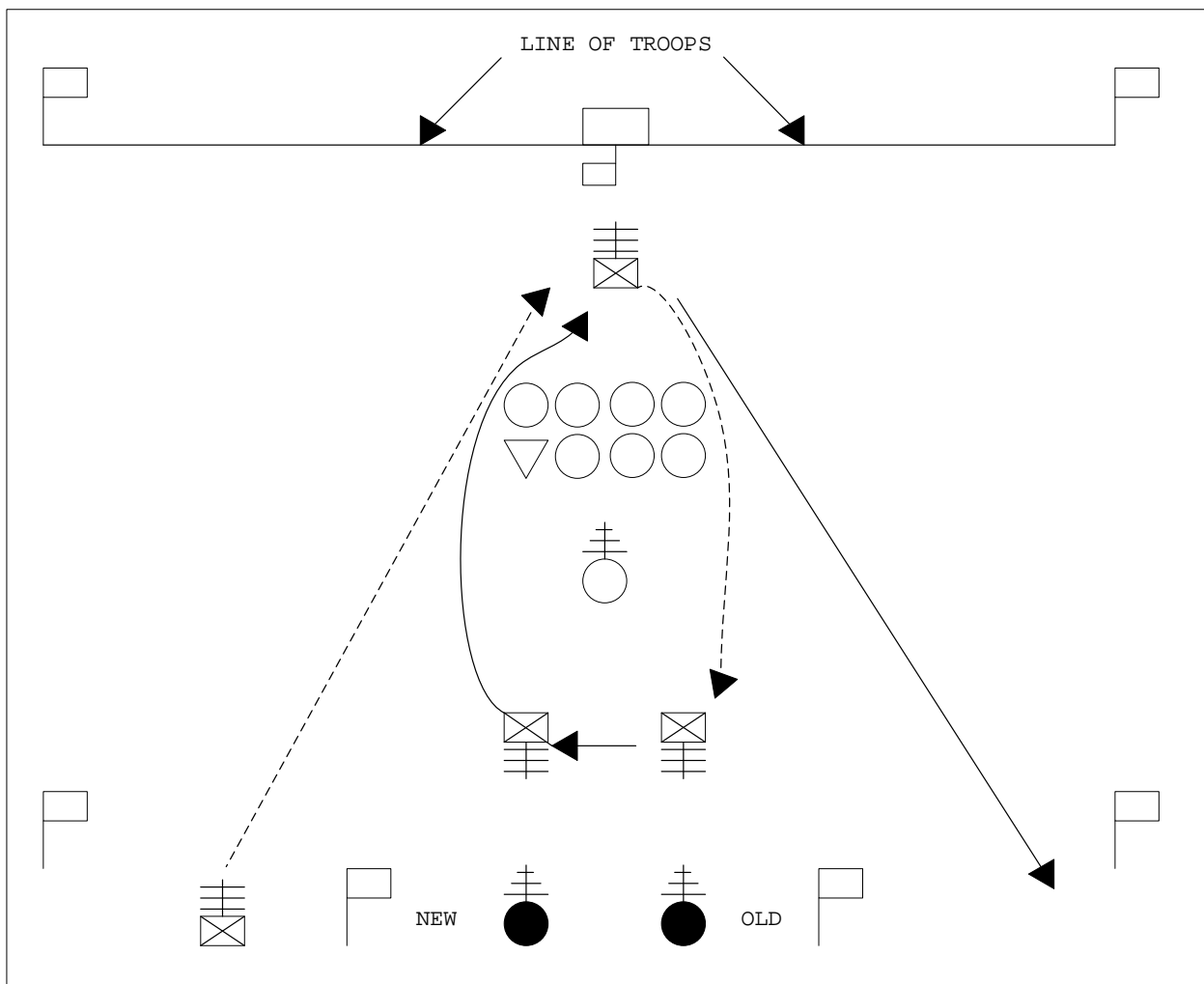

Figure 7-1.--Delivering and Returning the Colors.

h. Commander of troops commands **"Order, ARMS."** The unit executes order arms and/or carry sword.

(1) The color guard remains at carry colors and receives the organizational colors from the sergeant major. The color guard then executes order colors. (If honors are to be played as the next sequence, the color guard will remain at carry colors.)

(2) After the sergeant major has cleared the parade field, the commander of troops will face the line of troops.

Note: If the incoming commander rates honors, continue with paragraph 4.i. of this chapter. If the incoming commander does not rate honors, continue with paragraph 4.1. of this chapter. (Honors will be rendered to all General Officers participating in the ceremony, unless otherwise deferred. Honors are not required for those attending the ceremony as a guest.)

i. Commander of troops commands "**Present, ARMS.**" All execute, present arms/present sword.

j. Commander of troops commands (while facing the reviewing area) "**Staff, Present, SWORD.**" The staff executes present sword.

<p>NARRATOR: "LADIES AND GENTLEMEN, PLEASE RISE FOR HONORS TO <u>(RANK AND NAME OF COMMANDER)</u>." (The band plays appropriate honors and gun salutes are fired.)</p>

Note: The organizational color bearer salutes on the first note and terminates on the last note (last gun) of honors. After honors are complete, the narrator speaks.

<p>NARRATOR: "LADIES AND GENTLEMEN, PLEASE BE SEATED."</p>

k. Commander of troops commands "**Staff, Order, SWORD.**" The commander of troops and staff execute. The commander of troops goes to carry sword and faces the line of troops.

l. Commander of troops commands "**Order, ARMS**" and "**Parade, REST.**" The unit, along with color guard, executes. The commander of troops then faces about.

m. Commander of troops commands "**Staff, Parade, REST.**"

(1) The staff and commander of troops execute.

(2) The narrator then delivers a microphone (if available), to the outgoing commander. The commander makes remarks then passes the microphone to the incoming commander who makes his/her remarks. After the incoming commander's remarks, the microphone is retrieved. Both commanders return to their positions in the reviewing area assuming the position of attention.

Note: If the reviewing officer or the senior officer present other than the commanders desire to make remarks, they will do so prior to the outgoing and incoming commanders.

n. Commander of troops commands "**Staff, ATTENTION.**" The staff and commander of troops execute. The commander of troops goes to carry sword and faces the line of troops.

o. Commander of troops commands **"Battalion/Squadron, ATTENTION."** The unit executes. The commander of troops then faces the reviewing area.

p. Incoming Commander Commands

- (1) **"DISMISS THE COMMAND"** (or)
- (2) **"MARCH THE COMMAND IN REVIEW."**

Note: Follow remaining parade sequence for "Dismissing the Command" or "Pass in Review" as explained in enclosure 2, chapter 5.

5. Sequence of Events for a Change of Command with Promotion

a. If the incoming commander is to be promoted as part of the ceremony, the colors are not trooped at the beginning of the parade sequence. The sequence of events begins after the change of command, and the command has been presented to the "Promoting/Awarding Official," who is normally senior to both the incoming and outgoing commanders. After honors, if appropriate, (see paragraph 4.i. of this chapter) are complete, the unit is at order arms.

b. Commander of troops commands **"Officer to be Promoted, and All Colors, Center, MARCH."**

(1) On the preparatory command **"Colors,"** the staff executes carry sword. On the command **"Center",**

(a) The staff executes a right face, commander of troops commands **"MARCH,"** the staff marches 8-10 paces, halts, and executes a left face without command and remains at carry sword.

(b) The color guard executes carry colors.

(c) The commander of troops (once the staff has moved), marches to a point, 10 paces in front of the color guard, halts, salutes, and executes an about face.

(2) On the command of execution **"MARCH:"**

(a) The commander of troops and the color guard step off and march forward to a point of approximately 5-10 paces in front of the promoting official. The commander being promoted then takes their position in front of the colors as described for retirees in enclosure 2, chapter 6.

(b) As the color guard passes, the staff executes left face and returns 8-10 paces to its previous position, executes a right face, and executes order sword on command of the adjutant. The commander of troops salutes, and reports to the reviewing officer **"Sir/Ma'am, Officer(s) to be Promoted and All Colors are Present."**

c. Promoting official commands **"PRESENT THE COMMAND."** The commander of troops returns to carry sword, faces to the right as in marching, presents sword while passing the colors, and returns to their position in the staff. Facing the line of troops.

d. Commander of troops commands **"Present, ARMS."** (Faces about and commands) **"Staff, Present, SWORD."** (The command is then presented for the *"National Anthem."*)

e. After the last note, the commander of troops commands **"Staff, Order, SWORD."** Commander of troops executes carry sword, faces about and commands **"Order, ARMS."**

Note: As an option, after the promotion is presented, the "Promoting Official" may make remarks followed by the old and new commanders. Remarks are made at this time in place of remarks immediately following the passing of the organizational colors. If this option is used, the commander of troops will place the command at **"Parade, REST"** until after the remarks then return the command to **"ATTENTION,"** and follow the remainder of the sequence below.

f. After the promotion is presented, the reviewing officer moves back to the reviewing area and the sergeant major departs the field. The commander of troops, seeing the reviewing officer back in position goes to carry sword.

g. Commander of troops commands **"POST THE COLORS"** and **"Staff, Carry, SWORD."** The commander of troops and staff execute carry sword. The color guard executes carry colors.

h. Commander of troops commands **"Staff, Right, FACE"** and **"Staff, Forward, MARCH."** The commander of troops and staff execute.

(1) Color guard executes a countermarch and moves back to its position on line of troops, countermarches, halts and goes to order colors. (See enclosure 2, chapter 6, figure 6-4.)

(2) The commander of troops and staff march forward sufficiently for the colors to pass, halts, does a left face without command and remains at carry sword. When the colors have passed, the commander of troops moves the staff back to its position, halts and executes a right face without command and goes to order sword. However, the commander of troops faces the line of troops, remaining at carry sword. When the color guard is in position, and at order colors, the commander of troops faces the reviewing area.

i. Once the promotion is presented, the outgoing commander takes his/her post in the reviewing area. The change of command then proceeds as described in paragraph 4.p. of this chapter.

6. Sequence of Events for a Change of Command with Presentation of Awards and/or Retirement

a. If the outgoing commander is to receive an award and/or retire as part of the change of command ceremony, the colors are not trooped at the beginning of the parade ceremony. The sequence of events begins after the change of command, and the commander of troops is facing the reviewing area. The "Retiring Official," who is normally senior to both the incoming and outgoing commanders takes his/her post in the reviewing area.

b. Commander of troops commands **"Officer(s) to be Retired, and All Colors, Center, MARCH."**

(1) On the preparatory command "**Colors,**" the staff executes carry sword. On the command "**Center,**

(a) The staff executes a right face, commander of troops commands "**MARCH,**" the staff marches 8-10 paces.

(b) The color guard executes carry colors.

(c) The commander of troops (once the staff has moved), marches to a point, 5-10 paces in front of the color guard, halts, salutes, and executes an about face.

(2) On the command of execution "**MARCH,**

(a) The commander of troops and the color guard step off and march forward to a point approximately 10 paces in front of the retiring official. The commander being retired then takes their position in front of the colors as described for retirees in enclosure 2, chapter 6.

(b) As the color guard passes, the staff returns, as described in enclosure 2, chapter 2, paragraph 4, executes left face and returns 8-10 paces to its previous position, executes a right face without command, and executes order sword on command of the adjutant. The commander of troops salutes, and reports to the reviewing officer "**Sir/Ma'am, All Officers to be Retired and All Colors are Present.**"

c. Reviewing officer commands "**PRESENT THE COMMAND.**" The commander of troops returns to carry sword, faces to the right as in marching, presents sword while passing the colors, and returns to their position in the staff facing the line of troops.

d. Commander of troops commands "**Present, ARMS.**" (Faces about and commands) "**Staff, Present, SWORD.**" (The command is then presented for the "*National Anthem.*")

e. After the last note, the commander of troops commands "**Staff, Order, ARMS.**" Commander of troops executes carry sword, faces about and commands "**Order, ARMS.**"

f. The award and/or retirement is affected per the procedures in enclosure 2, chapter 6.

Note: As an option after the award or retirement is effected, the "Retiring Official" may make remarks followed by the old and new commanders. Remarks are made at this time in place of remarks immediately following the passing of the organizational colors. If this option is used, the commander of troops will place the command at "**Parade, REST**" until after the remarks then return the command to "**ATTENTION,**" and follow the remainder of the sequence below.

g. After the last award and/or retirement is effected, the reviewing officer moves back to the reviewing area. The commander of troops, seeing the reviewing officer back in position, goes to carry sword.

h. Commander of troops commands "**POST THE COLORS**" and "**Staff, Carry, SWORD.**" The commander of troops and staff execute carry sword. The color guard executes carry colors.

i. Commander of troops commands **"Staff, Right, FACE"** and **"Staff, Forward, MARCH."** The commander of troops and staff execute.

(1) Color guard executes a countermarch and moves back to its position on the line of troops, countermarches, halts and goes to order colors. (See enclosure 2, chapter 6, figure 6-4.)

(2) The commander of troops and staff march forward sufficiently, as described in enclosure 2, chapter 2, paragraph 4.h.(2), for the colors to pass, halts, does a left face and remains at carry sword. When the colors have passed, the commander of troops moves the staff back to its position, halts and executes a right face without command and goes to order sword. However, the commander of troops faces the line of troops, remaining at carry sword. When the color guard is in position, and at order color, the commander of troops faces the reviewing area.

j. Once colors are returned to the line of troops, the outgoing and incoming commanders take their post in the reviewing area. The command is then marched in review or dismissed.

7. Honors for General Officers and High Ranking Civilians Participating in the Change of Command. It is not unusual for General Officers and high ranking civilians to observe a change of command ceremony as invited guests. Unless they are participating in the ceremony as the Reviewing Official, honors are not rendered since the outgoing and incoming commanders, during their remarks, recognize them. If participating, the following procedures will be used.

a. When the selected ceremony reaches the point in time when the command is presented to the outgoing commander, the command is first presented to the General Officer. The narrator would introduce the general officer by announcing;

NARRATOR: "LADIES AND GENTLEMEN, PLEASE RISE FOR HONORS TO _____" (e.g., The Commanding General, Second Marine Division, Major General Smith).

b. The command is presented and honors are rendered.

NARRATOR: "LADIES AND GENTLEMEN, PLEASE BE SEATED."

c. The General Officer returns to his/her seat in the reviewing stand.

d. The command is then placed at the order and the commander of troops faces the reviewing area. The outgoing commander then moves to his/her position in the reviewing area, and the change of command resumes its normal sequence as outlined in paragraph 4 of this chapter.

Chapter 8

Relief and Appointment of the Sergeant Major

TABLE OF CONTENTS

<u>IDENTIFICATION</u>	<u>TITLE</u>	<u>PAGE</u>
1.	General.....	8-2
2.	Occasion.....	8-2
3.	Formation.....	8-2
4.	Sequence of Events for the Relief and Appointment Ceremony without an Award, or Retirement.....	8-2
5.	Sequence of Events for the Relief and Appointment Ceremony with Presentation of Award and/or Retirement.....	8-6
Figure 8-1	Sergeants Major Take Position.....	8-3
Figure 8-2	Position of the Sergeants Major After Relief and Appointment.....	8-5

Chapter 8

Relief and Appointment of the Sergeant Major

1. General. Ceremonies for relief and appointment of sergeants major in the Marine Corps shall be conducted as prescribed in this Chapter.

2. Occasion. When practicable, the ceremony set forth below will be held upon the relief of the old and appointment of the new sergeant major within units of battalion or squadron size and larger. The ceremony may be as simple as a formation of the unit affected or a review or a parade. For example, if the old sergeant major is transferring then a formation or review is appropriate. If the old sergeant major is retiring then a retirement parade in conjunction with the relief and appointment ceremony is appropriate.

3. Formation

a. The command is formed for the appropriate ceremony (e.g., unit formation, parade or review) per enclosure 1, chapters 11 and 12, and/or enclosure 2, chapter 4 and/or chapter 5.

b. If no award, or retirement is effected as part of the ceremony then the colors will be trooped.

4. Sequence of Events for the Relief and Appointment Ceremony without an Award, or Retirement

a. The sequence for the relief and appointment of the sergeants major begins after the commander of troops has presented the command to the unit commander, and the command is back at order arms if a parade, or after trooping the line if a review.

b. Commander of troops commands **"Sergeants Major, Front and Center, MARCH."**

c. The sergeants major move from their seats in the reviewing stand to positions five paces in front of the reviewing area, the old sergeant major on the right. (See figure 8-1.) The old sergeant major will carry the sword of office in the unrigged carry position under the left arm as prescribed in figure 5-18 of enclosure 1.

Note: The old and new sergeants major will only exchange a noncommissioned officer's sword. The exchange of k-bar knives, swagger sticks, or any other form of symbolism, is expressly forbidden.

NARRATOR: SINCE 1875, NONCOMMISSIONED AND STAFF NONCOMMISSIONED OFFICERS HAVE CARRIED THE NONCOMMISSIONED OFFICER SWORD AS A SYMBOL OF THEIR ABILITY AND PRESTIGE AS ENLISTED LEADERS OF THE MARINE CORPS. THE SERGEANT MAJOR, AS THE SENIOR ENLISTED LEADER AND ADVISOR, IS THE KEEPER OF TRADITIONS FOR HIS OR HER UNIT. TODAY'S EMBLEMATIC PASSING OF THE SWORD OF OFFICE SIGNIFIES THE TRANSFER OF THIS SACRED TRUST FROM ONE SERGEANT MAJOR TO ANOTHER.

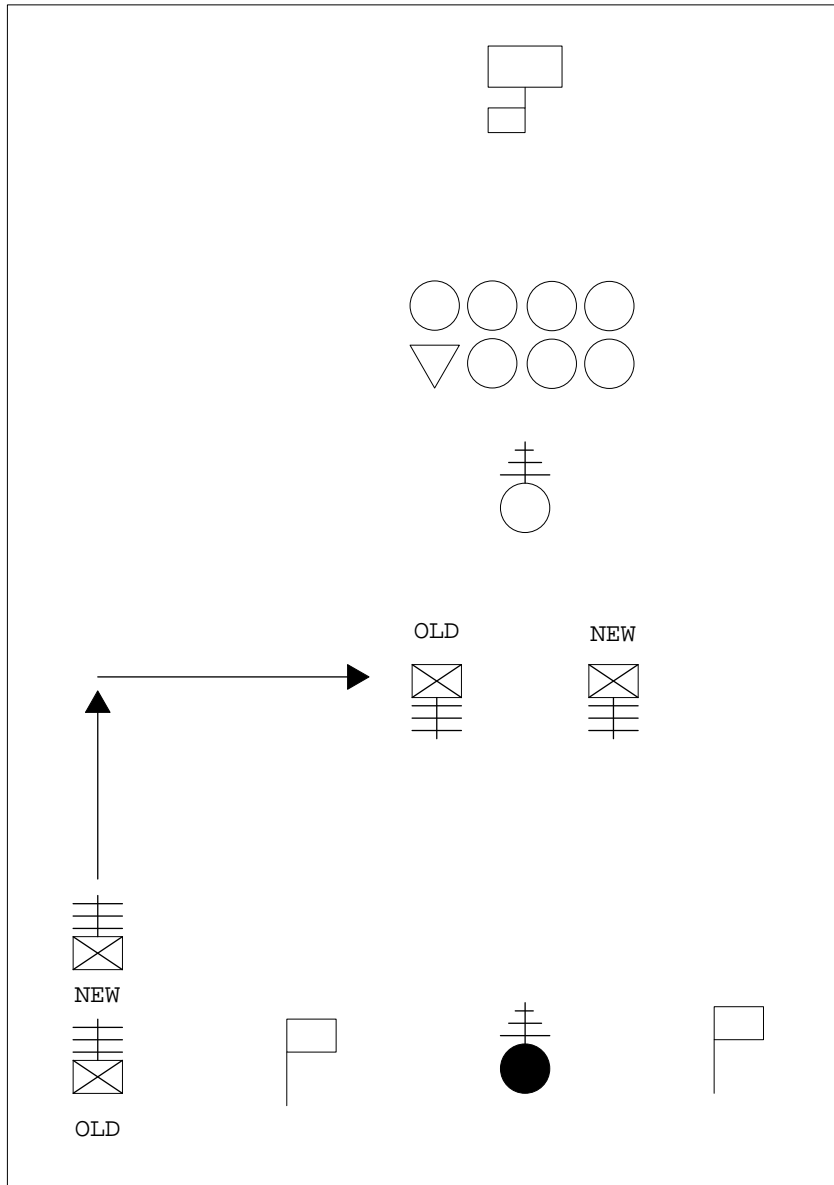

Figure 8-1.--Sergeants Major take Position.

d. Relief and Appointment

NARRATOR: READS THE ORDERS FOR THE OUTGOING SERGEANT MAJOR.

(1) The old sergeant major then steps front and center of the unit commander, salute and reports **"Sir/Ma'am, Sergeant Major _____ reporting as the old sergeant major."** The unit commander returns the salute and states **"You are relieved."** The old sergeant major then yields the responsibility of his/her post by surrendering the sword of office to the unit commander, who places it at unrigged carry. The old sergeant major then moves to his/her new position approximately three paces to the left and abreast of the unit commander. (See figure 8-2.)

NARRATOR: READS THE ORDERS FOR THE INCOMING SERGEANT MAJOR.

(2) The new sergeant major then steps front and center of the unit commander, salutes and reports **"Sir/Ma'am, Sergeant Major _____ reporting as the new sergeant major."** The unit commander returns the salute and passes the sword to the new sergeant major, who assumes the unrigged carry. The unit commander then states **"TAKE YOUR POST."** The new sergeant major then moves to his/her position between the unit commander and old sergeant major.

e. Commander of troops commands **"Parade, REST."** The command executes parade rest. The commander of troops then faces the reviewing area.

f. Commander of troops commands **"Staff, Parade, REST."** The commander of troops, staff, and color guard execute parade rest. The sergeants major return to their seats. The microphone is delivered to the unit commander who makes their remarks. The microphone is then passed to the old sergeant major for remarks and then the new sergeant major for remarks. Once all remarks are complete, the microphone is retrieved.

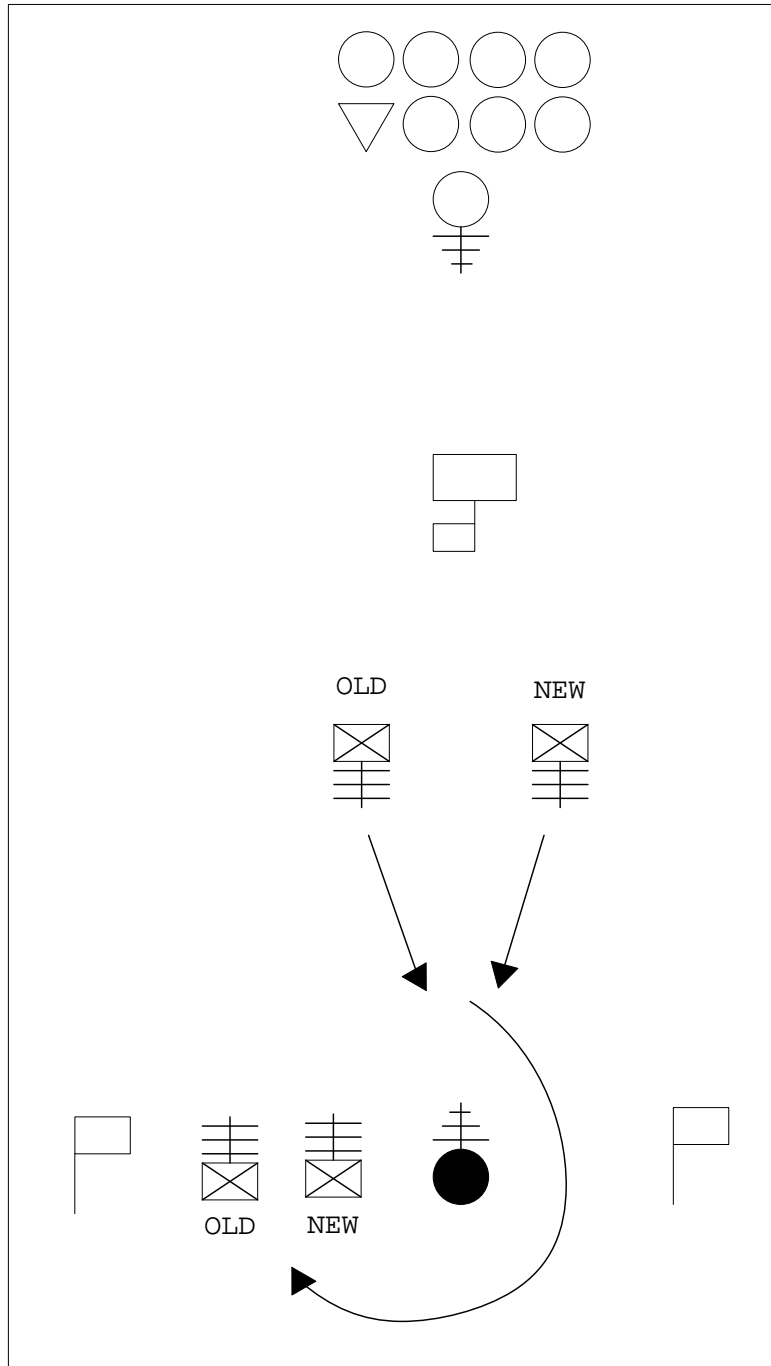

Figure 8-2.--Position of the Sergeants Major after Relief and Appointment.

g. Commander of troops commands "**Staff, ATTENTION.**" The commander of troops, staff, and color guard execute attention. The commander of troops then faces the line of troops.

h. Commander of troops commands "**Battalion, ATTENTION.**" The battalion executes attention. The commander of troops then faces the reviewing area.

i. The ceremony would then continue as prescribe for a review (see

enclosure 2, chapter 4), a parade (see enclosure 2, chapter 5) or unit formation (e.g., the command is marched in review, dismissed, etc.).

5. Sequence of Events for the Relief and Appointment Ceremony with Presentation of Awards and/or Retirement

a. If the outgoing sergeant major is to receive an award and/or retire as part of the ceremony, the colors are not trooped at the beginning of the parade sequence. The sequence of events begins after the relief and appointment, and the commander of troops is facing the reviewing area as in paragraph 5.b. of this chapter. The "Awarding/Retiring Official," takes his/her post in the reviewing area.

b. Commander of troops commands **"Marine to be Decorated/Retired, and All Colors, Center."**

(1) On the preparatory command **"Colors,"** the staff executes carry sword. On the command **"Center,"**

(a) The staff executes a right face, commander of troops commands **"MARCH,"** the staff marches 8-10 paces, halts, and executes a left face without command remains at carry sword.

(b) The color guard executes carry colors.

(c) The commander of troops (once the staff has moved), marches to a point, 5-10 paces in front of the color guard, halts, salutes, and executes an about face.

(2) On the command of execution **"MARCH,"**

(a) The commander of troops and the color guard step off and march forward to a point approximately 5-10 paces in front of the awarding/retiring official. The sergeant major being awarded/retired then takes his/her position in front of the colors as described for retirees in enclosure 2, chapter 6.

(b) As the color guard passes, the staff executes left face and returns 8-10 paces, as described in enclosure 2, chapter 2, paragraph 4, to its previous position, and executes a right face and executes order sword. The commander of troops salutes, and reports to the awarding/retiring official **"Sir/Ma'am, Marine to be Decorated/Retired, and All Colors are Present."**

c. Awarding/retiring official commands, **"PRESENT THE COMMAND."** The commander of troops returns to carry sword, faces to the right as in marching, presents sword while passing the colors, returns to his/her position in the staff, and faces the line of troops.

d. Commander of troops commands **"Present, ARMS."** (Faces about and commands.) **"Staff, Present, SWORD."** (The command is then presented for the "National Anthem.") The color guard will execute present and order when the staff executes.

e. After the last note, the commander of troops commands **"Staff, Order, ARMS."** Commander of troops executes carry sword, faces about and commands

"Order, ARMS."

f. The award and/or retirement is conducted per the procedures in enclosure 2, chapter 6.

Note: As an option, the new sergeant major may make his/her remarks immediately following the relief and appointment. After the award or retirement is complete, the "Awarding/Retiring Official" may make remarks followed by the old sergeant major. This allows the old sergeant major the option of speaking last during his/her retirement ceremony. If this option is used, the commander of troops will place the command at **"Parade, REST"** until after the remarks are complete then return the command to **"ATTENTION,"** and follow the remainder of the sequence below.

g. After the award and/or retirement is complete, the reviewing officer moves back to the reviewing area and the commander of troops, seeing the reviewing officer back in position, goes to carry sword.

h. Commander of troops command **"POST THE COLORS"** and **"Staff, Carry, SWORD."** The commander of troops and staff execute carry sword. The color guard executes carry colors.

i. Commander of troops commands **"Staff, Right, FACE"** and **"Staff, Forward, MARCH."** The commander of troops and staff execute.

(1) Color guard executes a countermarch and moves back to its position on the line of troops, countermarches, halts and goes to order colors. (See enclosure 2, chapter 6, figure 6-4.)

(2) The commander of troops and staff march forward, as described in enclosure 2, chapter 2, paragraph 9, sufficiently for the colors to pass, halts, does a left face without command and remains at carry sword. When the colors have passed, the commander of troops moves the staff back to its position, halts and executes a right face and goes to order sword. However, the commander of troops faces the line of troops, remaining at carry sword. When the color guard is in position, and at order colors, the commander of troops faces the reviewing area.

j. Once colors are returned to the line of troops, the old and new sergeants major take their post in the reviewing area. The command is then marched in review or dismissed.

k. The ceremony would then continue as prescribe for a review (see enclosure 2, chapter 4), a parade (see enclosure 2, chapter 5) or unit formation (e.g., the command is marched in review, dismissed, etc.).

Chapter 9

Activation and Deactivation Ceremony

TABLE OF CONTENTS

<u>IDENTIFICATION</u>	<u>TITLE</u>	<u>PAGE</u>
1.	General.....	9-2
2.	Activation of an Organization.....	9-2
3.	Deactivation of an Organization.....	9-3
4.	Joint Deactivation and Activation Ceremony.....	9-5
Figure 9-1	Retire the Guidons.....	9-4
Figure 9-2	Colors Center.....	9-7
Figure 9-3	Post the Guidons.....	9-9

Chapter 9

Activation and Deactivation Ceremony

1. General. On the occasion that Marine Corps organizations of battalion or squadron size and larger are activated or deactivated, the ceremonies in this Chapter will be used as guidelines. The term sergeant major refers to either the unit level sergeant major or the senior enlisted representative of the unit.

2. Activation of an Organization

a. The preferred ceremony for the activation of an organization is a parade. The troops are marched on as described in enclosure 2, chapter 5.

b. The colors march on with the command, and the national and organizational colors are cased.

c. After presenting the command to the commander or officer activating the unit, the command is returned to the order.

d. Commander of troops commands **"All Colors, Center, MARCH."**

(1) The commander of troops moves to bring the colors forward as described in enclosure 2, chapter 6, paragraphs 5.a. and 5.b. When the colors are forward, the commander of troops salutes the commander and reports **"Sir/Ma'am, (Units designation) Colors are Present."**

(2) The commander or officer activating the unit and sergeant major move forward to the color guard. As they approach, the color guard, the national and organizational color bearers lower them sufficiently for the commander, assisted by the sergeant major, to uncased the national and organizational colors. As the colors are uncased;

<p>NARRATOR READS PERTINENT EXTRACTS FROM THE ORDERS ACTIVATING THE UNIT.</p>
--

(3) The national colors will be uncased first and raised back to the carry before the organizational colors. After the colors are uncased, the color bearers returns them to the carry. The commander and sergeant major salute the colors before the commander returns to his/her post, and the sergeant major departs from the field.

e. Commander commands **"POST THE GUIDONS."** The guidon bearers march to a position in front of their respective company commanders. The company commanders will unfurl the guidons, and the guidon bearers will return to their normal position one pace to the left and one pace to the back of the company commanders.

Note: The company guidon bearers will begin the ceremonies with their guidons furled.

f. Commander commands, **"PRESENT THE COMMAND."** The commander of troops conducts present the command as outlined in enclosure 2, chapter 6, paragraph 5.c.

(1) Band plays "*National Anthem.*"

(2) After the command is presented and brought back to the order, it is placed at parade rest, and the commander or other officials deliver remarks.

(3) After all remarks are completed, the command is brought to attention, the colors are posted and a march in review as described in enclosure 2, chapter 5 conducted.

3. Deactivation of an Organization

a. The preferred ceremony for the deactivation of an organization is a review. The troops are unarmed and formed prior to the review as described in enclosure 2, chapter 4, paragraph 7. During the review, no awards are issued, and the colors are not brought forward. While the line is being trooped, the narrator would read the lineage, honors and brief history of the unit. After the commander has finished trooping the line, and the command is back at attention, the commander directs the commander of troops to "**MARCH THE COMMAND IN FINAL REVIEW.**" The command marches in review as described in enclosure 2, chapter 5, however, after marching in review, the command reforms on the line of troops. After the unit has reformed, the band, commander of troops and staff are returned to their original position.

b. Commander of troops commands, "**All Colors, Center, MARCH.**" The commander of troops moves to bring the colors forward as described in enclosure 2, chapter 6, paragraphs 5.a. and 5.b. When the colors are forward, the commander of troops salutes the commander and reports "**Sir/Ma'am, (Units designation) Colors are Present.**"

c. Commander commands, "**PRESENT THE COMMAND.**" The commander of troops moves to present the command as outlined in enclosure 2, chapter 6, paragraph 5.c.

(1) Band plays "*National Anthem.*"

(2) After the command is presented, brought back to the order and placed at parade rest, the commander or other officials deliver remarks.

d. After all remarks are complete, the command is brought back to attention. The commander of troops then directs that the company/battery guidons be retired by commanding "**Retire, GUIDONS.**" (See figure 7-1.) On this command, unit first sergeants move from their position in the formation by the most direct route and to a position 1 pace in front of and facing the guidon bearer. The guidon is passed to the first sergeant. After receiving the guidon, the first sergeants face about and march by the most direct route to their designated position on either side of the reviewing area where guidon stands have been staged. They halt together, place the guidons in the stands, face about and return to their position in the formation.

e. Once the first sergeants have returned to their position in the formation, the color guard goes to the carry, and the commander and sergeant major move forward to the color guard. As they approach the color guard, the national and organizational color bearers will remove the flag staff from the sling by grabbing the ferrule with their left hand. The color bearers will move the ferrule to the left side of their body and extend

their right arm directly in front of them until the flag staff is parallel to the deck allowing the colors to be cased. The commander, assisted by the sergeant major, will case the national and organizational colors. As the colors are being cased;

NARRATOR READS PERTINENT EXTRACTS FROM THE ORDERS DEACTIVATING THE ORGANIZATION. (REFER TO UNIT'S MARINE CORPS BULLETIN (MCBUL) 5400 SERIES).

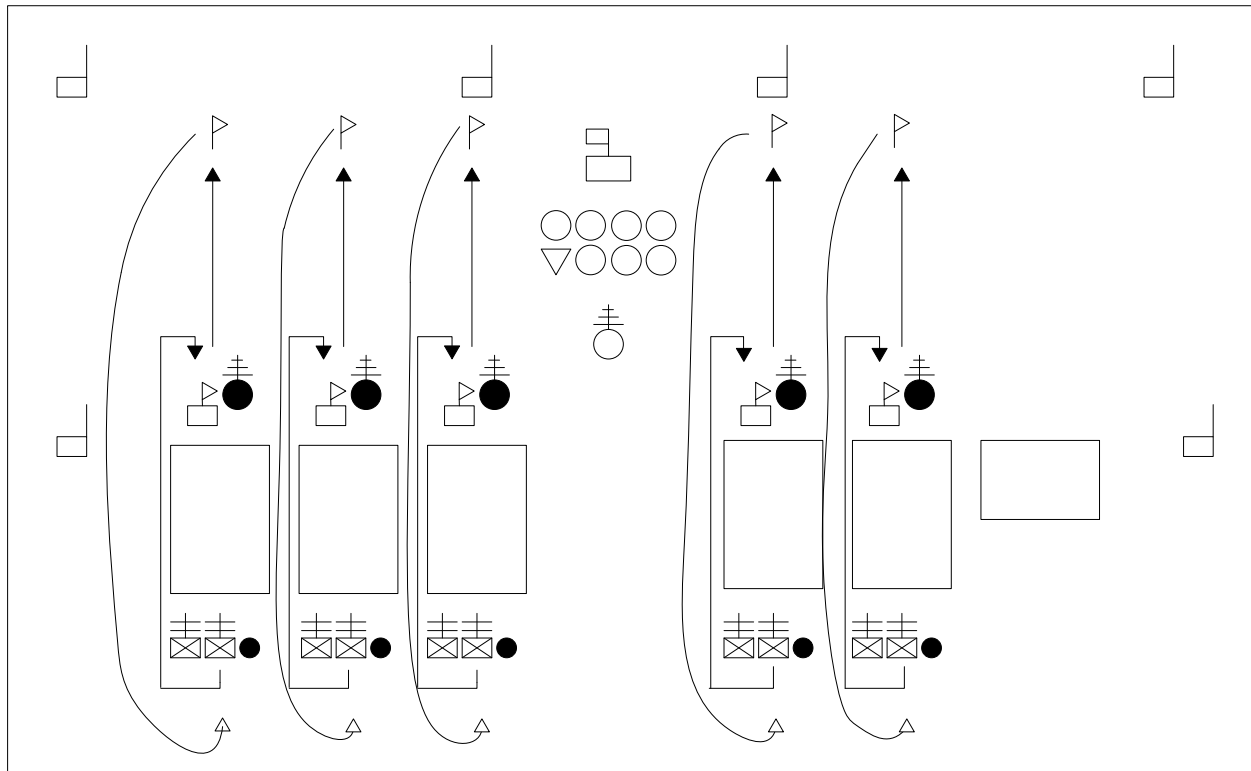

Figure 9-1.--Retire the Guidons.

f. When the colors are cased, the national and organizational color bearers return to the carry, and the commander and sergeant major return to their posts.

g. Commander commands "**RETIRE THE COLORS.**" The color guard executes a countermarch and halts facing the line of troops.

(1) The commander of troops then presents the command.

(2) The color guard executes a right turn and marches from the field while the band plays martial music.

(3) After the color guard has cleared the field, the commander of troops brings the command to the order and faces the commander.

h. Commander commands "**DISMISS THE BATTALION.**"

i. The commander of troops and commander exchange salutes. The commander of troops then faces the line of troops and orders the company commanders to dismiss their companies. Salutes are exchanged between the company commanders and commander of troops. The commander of troops then dismisses the staff, and the company commanders dismiss their companies, in sequence, from right to left.

j. The band plays "*Auld Lang Syne*" and retires from the field.

k. The narrator announces the end of the ceremony.

4. Joint Deactivation and Activation Ceremony

a. On the occasion when two Marine Corps organizations of battalion or squadron size and larger are merged in to one larger organization, the ceremony in this chapter will be used as a guideline.

b. The preferred ceremony for the activation of an organization is a parade. The troops are marched on as described in enclosure 2, chapter 5 for a regimental parade.

c. The next higher headquarters of both merging units will conduct the parade and will normally be done using the procedures for a regimental formation as described in enclosure 2, chapter 5.

d. The colors of the next higher unit will be used for the ceremony with those of the merging units uncased and massed behind the color guard per the procedures in enclosure 1, chapter 7. The colors of the new unit to be formed by the merger will be cased and centered between the retiring colors in the mass colors formation. The colors will march on with the command.

e. The parade will be conducted as prescribed in enclosure 2, chapter 5 up to the and including the presentation of the command and honors. After honors, the commander of troops commands. **"All Colors, Center, MARCH."** On the command **"Colors,"** the color guard goes to carry colors and the staff goes to carry sword.

(1) On the command **"Center,"** the staff executes a right face.

(2) On the command **"MARCH,"** the staff steps off and moves forward 8-10 paces, halts, executes a left face without command and remains at carry sword.

(3) The colors being retired and the colors of the new unit step off and march to a position 5-10 paces in front of and centered on the color guard.

(4) The commander of troops, once the staff has clear, marches forward to the line of organizational colors, halts 5-10 paces in front of them, salutes the colors, and faces about.

f. Commander of troops commands **"Forward, MARCH."**

(1) The commander of troops, colors to be retired and uncased, and the color guard march forward towards the reviewing area. The commander of troops commands **"Detachment, HALT"** so that the detail is halted with the commander of troops 5-10 paces in front of and centered on the reviewing

officer. (See enclosure 2, chapter 6, figure 6-4.) The color guard remains at the carry. (See figure 9-2.)

(2) The adjutant commands the staff to left face and marches the staff back to its position, where the staff halts, faces the reviewing area and goes to order sword. The commander of troops then salutes the reviewing officer and reports **"Sir/Ma'am, all Colors are Present."** The commander returns the commander of troops' salute.

g. Commander commands, **"PRESENT THE COMMAND."** The commander of troops moves to present the command as outlined in enclosure 2, chapter 6, paragraph 5.c.

(1) Band plays *"National Anthem."*

(2) After the command is presented, brought back to the order and placed at parade rest, the commander of troops commands **"Retire, GUIDONS."** (See figure 9-1.)

(3) On this command, unit first sergeants move from their position in the formation by the most direct route and to a position one pace in front of and facing the guidon bearer. The guidon is passed to the first sergeant. After receiving the guidon, the first sergeants face about and march by the most direct route to their designated position on either side of the reviewing area where guidon stands have been staged. They halt together, place the guidons in the stands, face about and remain at their position in front of the guidons (except the first sergeant of the Headquarters and Service Company of the left battalion who will return to his/her normal position in the formation.)

Note: These will be double guidon stands with an empty side (left) for the retired guidon and the guidon for the newly activated unit pre-staged on the right. The guidon for the newly activated unit will be furled.)

h. At this time, the organizational colors of the merging units will be retired simultaneously.

(1) The commanders from both deactivating units, assisted by their sergeants major, will step forward to case their organizational colors. As they approach the color guard, the organizational color bearers will remove the flag staff from the sling by grabbing the ferrule with their left hand and keeping the staff centered on the body. To lower the colors sufficiently enough to be cased, the color bearers will move the lower ferrule to the left side of their body and extend their right arm directly in front of them until the flag staff is parallel to the deck. The commander and sergeant major will case their organizational colors. As the colors are cased;

<p>NARRATOR READS PERTINENT EXTRACTS FROM THE ORDERS DEACTIVATING THE UNITS.</p>

(2) The band plays *"Auld Lang Syne"* as the colors are cased.

(3) After the colors are cased, the color bearers return them to the carry and then passes the colors to the sergeant major. The sergeants major march from the field with the cased colors followed by the color bearer.

The commanders return to their post.

i. Once the colors are cased, the unit may be placed at parade rest and remarks made by the reviewing officer and/or the commanding officers of the two units that have been deactivated. Following remarks, the old commanders return to their seats, and the unit is brought back to attention.

j. The commander or officer activating the unit and sergeant major move forward to the color guard. As they approach the color guard, the organizational color bearer takes the cased colors from the sling and lowers it sufficiently for the commander, assisted by the sergeant major, to uncase the organizational colors.

(1) As the colors are uncased;

NARRATOR READS PERTINENT EXTRACTS FROM THE ORDERS ACTIVATING THE UNIT.

(2) After the new organizational color is uncased, the color bearer returns it to the carry. The commander returns to his/her post and the sergeant major departs from the field.

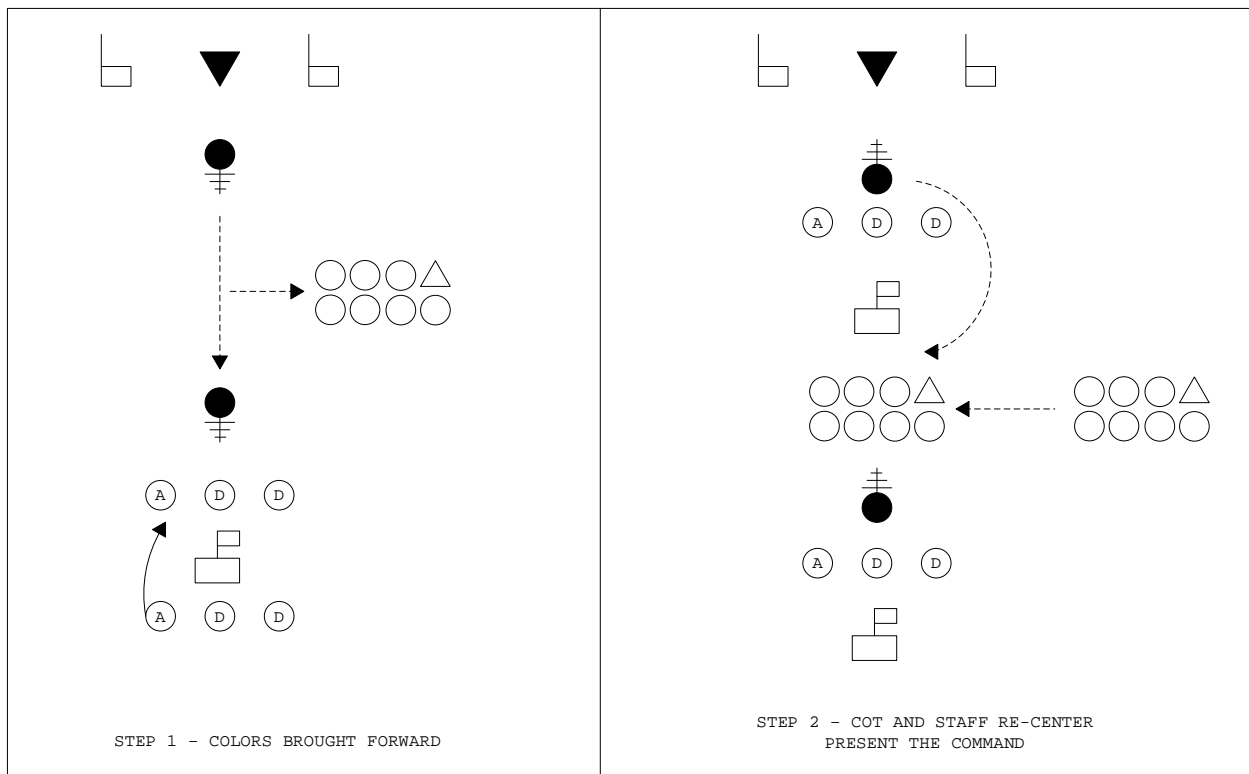

Figure 9-2.--Colors Center.

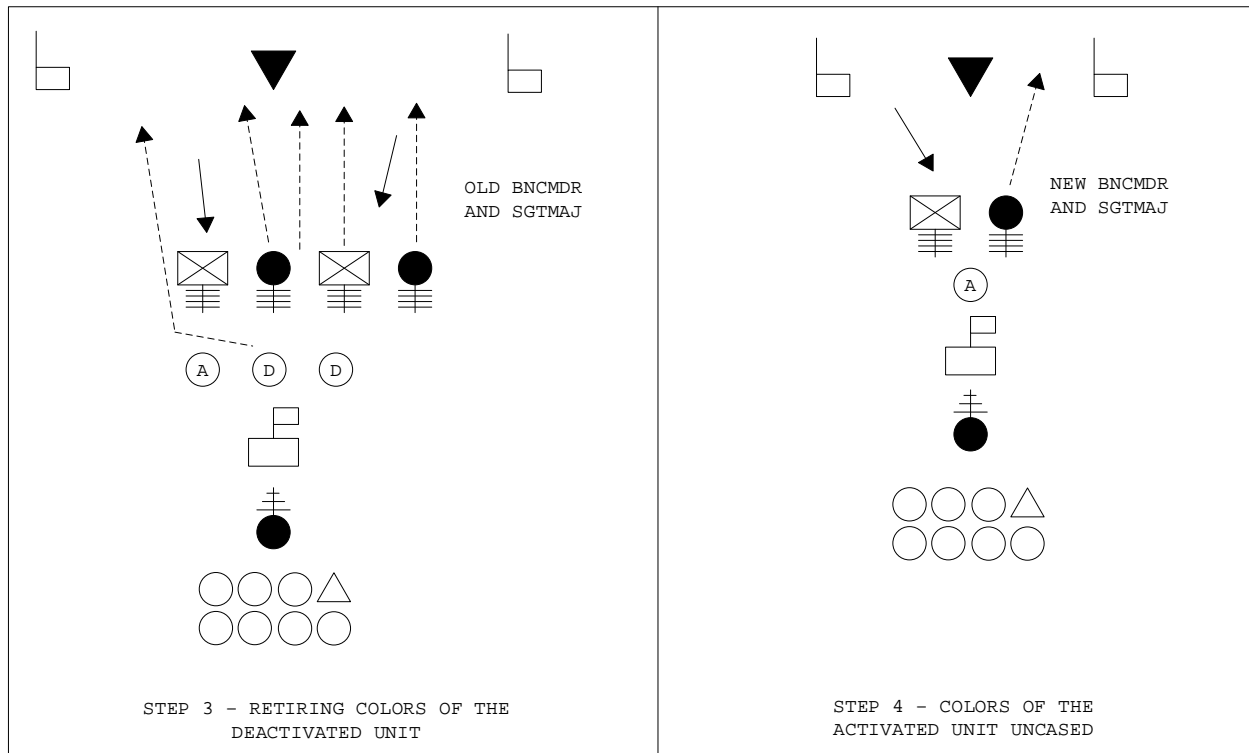

Figure 9-2.--Colors Center--Continued.

k. Commander commands **"POST THE GUIDONS."** The first sergeants face about and remove the new unit guidons from their position in the stand, unfurl it and march together by the most direct route to a position directly in front of the appropriate guidon bearer. (See figure 9-3.) They will pass the new guidon to the guidon bearer and return to their normal position in the formation.

Note: At the start of this ceremony, the two deactivating units each have a Headquarters and Service Company. Once the merger has occurred and the new unit activated, the Headquarters and Service Company of the right battalion becomes the new Headquarters and Service Company.

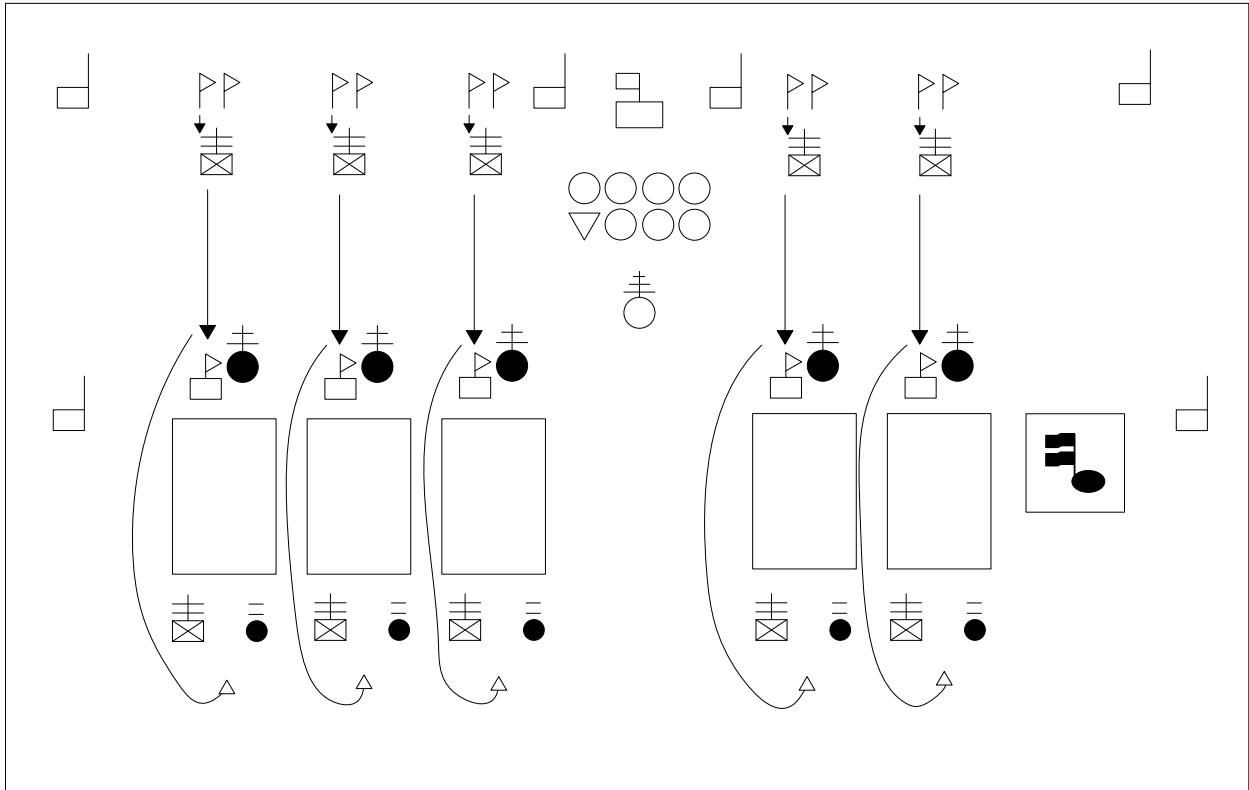

Figure 9-3.--Post the Guidons.

1. Commander commands "**PRESENT THE COMMAND.**"

(1) The commander of troops will present the command as outlined in enclosure 2, chapter 5, paragraph 7. After the command is presented and brought back to the order, it is placed at parade rest and the new commander delivers remarks.

(2) After all remarks are completed, the command is brought to attention and the colors are posted. The new unit's organizational colors will follow the color guard back to the line of troops and when the color guard countermarches, the organizational colors will march around and resume its position in the formation behind the color guard.

m. At this point, the command will march in review as described in enclosure 2, chapter 5.

Chapter 10

Honors

TABLE OF CONTENTS

<u>IDENTIFICATION</u>	<u>TITLE</u>	<u>PAGE</u>
1.	Prescribed Honors.....	10-2
2.	Rendering Honors to Personages Arriving for Official Visits Ashore.....	10-3
3.	Rendering Honors to Personages Departing After Official Visits Ashore.....	10-7
4.	Escort of Honor.....	10-7
5.	Additional Honors.....	10-7
6.	Gun Salute.....	10-7
7.	Honors for Official Visits of United States Officers.....	10-11
Table 10-1	Honors Matrix.....	10-11

Chapter 10

Honors

1. Prescribed Honors

a. See reference (i) for tables of prescribed honors to be rendered afloat.

b. Except as set forth below, the same salutes, honors, and ceremonies, insofar as practicable, are rendered in connection with official visits to Naval stations and Marine Corps posts and bases as are rendered on similar visits to Navy ships.

c. Normally, a unit other than the interior guard will be detailed as the honor guard at shore-based establishments.

(1) For a personage who merits a full guard, the honor guard will usually consist of at least two platoons of riflemen, a band and colors.

(2) If sufficient personnel are not available to meet this requirement, the full guard will consist of not less than one platoon of riflemen.

(3) For a personage who merits the guard of the day, the honor guard will consist of one platoon of riflemen.

(4) The band and colors will not be included unless the guard consists of at least two platoons.

d. The following elements required in honors afloat are omitted when rendering honors ashore:

(1) Manning the rail.

(2) Piping alongside or over the side.

(3) Side boys.

e. Only persons who are entitled honors and actually participate in any of the ceremonies described in enclosure 2, chapter 3 will be accorded honors during the ceremony. If several persons rating honors are participating in the same ceremony, then normally only the senior will receive honors. The exception to this is during a change of command when multiple honors may be appropriate, whereas honors will be given to all General Officers participating in the ceremony, unless otherwise deferred. Honors are not required for those attending the ceremony as a guest.

f. The senior person participating has the option of deferring honors to another that is also participating. Also, a person entitled to honors may defer a gun salute and elect instead to receive only musical honors.

2. Rendering Honors to Personages Arriving for Official Visits Ashore

a. See reference (i) for the appropriate musical honors, gun salutes and display of personal or national flags.

b. Officers and noncommissioned officers will normally be armed with the sword for these ceremonies. At such locations where the sword is not required, or available, those individuals will be armed with the pistol. Personnel so armed will execute the hand salute in lieu of present sword, and during the inspection of the honor guard, will execute inspection arms as the personage halts at their position.

c. The commanding officer, senior officer present, or the representative of either, is the host and participates in the ceremony described herein. The commander ascertains from the visiting personage whether he/she desires to inspect the honor guard, or to pass around the honor guard as in a review, or to do neither. The commander also ascertains from the visiting personage whether, following any of the three alternatives above, he/she desires the honor guard to march in review, or does not so desire. The commander then advises the personage of the action to be taken in the ceremony.

d. Prior to the arrival of the visiting personage, the honor guard will form on line at normal interval and at closed ranks. Platoon commanders are six paces in front of and centered on their platoons. The band takes position to the right of and on line with, the honor guard. The colors are posted in the center of the formation, excluding the band, and on line with the honor guard. Commander of the honor guard is 12 paces in front of and centered on the color guard.

e. The band sounds attention upon appearance of the visiting personage, and the honor guard is called to attention. The host welcomes the personage and escorts him/her to a position directly in front of and facing the commander of the honor guard, and takes his/her position to the left of the personage. The distance of this position from that of the commander of the honor guard will depend on local conditions, but it should be sufficient to permit the band and honor guard to pass in review. If sufficient space is not available to permit the march in review, the host will so inform the personage. The commander of the honor guard then executes carry sword, faces about and commands "**Present, ARMS,**" and the honor guard goes to present arms. The commander of the honor guard then faces about again and presents sword.

f. As the commander of the honor guard executes present sword, the band plays the appropriate honors. If a gun salute is to be fired, it is begun immediately after the last note of the music. During rendering of honors and the firing of the gun salute, all observers in the vicinity of the honor guard formation stand at attention facing the personage, or if he/she is not in view, toward the honor guard formation. Observers in uniform shall salute during the playing of musical honors and the firing of the gun salute.

g. If a personal flag or a foreign national flag is to be displayed during the visit, it is hoisted at the first note of the music. If a foreign national flag is to be displayed during the gun salute, it is hoisted or unfurled at the sound of the first gun salute and hauled down, or furled, at the sound of the last gun salute. If the personage merits display of the national flag during the gun salute, it is not necessary to display another ensign if one is already flying from the flagstaff of the installation.

h. On completion of musical honors or the gun salute, the commander of the honor guard executes carry sword, faces about and commands **"Order, ARMS,"** and the honor guard goes to order arms. The commander of the honor guard then faces about again, executes present sword, and reports **"Sir/Ma'am, the honor guard is formed."**

i. If the personage desires to inspect the honor guard, the host escorts the personage to a position three paces in front of the position of the commander of the honor guard.

(1) The commander of the honor guard then executes carry sword, faces about and commands **"PREPARE FOR INSPECTION."**

(2) The platoon commanders go to carry sword, face their platoons, and from right to left command **"Open Ranks, MARCH."** The platoon executes open ranks, and the platoon commander moves to verify alignment as described in enclosure 1, chapter 9, paragraph 17. After verifying alignment, the platoon commander moves to a position one pace to the right of and three paces in front of the guide, halts, faces down the front rank and commands **"Ready, FRONT"** and **"COVER."** The platoon commander then takes one step forward, halts, so that he/she is now three paces in front of the guide, faces right and goes to order sword.

(3) When all platoons have opened ranks and the platoon commanders are in position three paces in front of the guide, facing front, the commander of the honor guard faces about, executes present sword, and reports **"Sir/Ma'am, the honor guard is prepared for your inspection."**

(4) The commander of the honor guard then guides the personage, accompanied by the host and others of the official party, through the inspection, remaining at carry sword. The inspection commences at the right front of the band and proceeds along the line of platoons. As the personage halts in front of the platoon commander, the platoon commander executes present sword, and after being personally inspected, goes to carry sword, takes position on the right of the personage, and precedes the personage throughout the inspection of the platoon.

(5) The band begins playing as soon as the commander of the honor guard, the personage and the party step off in the direction of the band.

(6) Each member of the platoon will execute the movements to inspection arms for their weapon as the personage to be honored approaches, regardless of whether this personage halts and faces him directly or not. If the personage does not halt, and after the last member of the official party has passed the Marine's position, each member of the honor guard will execute port arms and order arms without command.

(7) Upon completion of the inspection of the Marine's platoon, the platoon commander, having led the personage down the rear of the last squad executes a column left and halts three paces in front of the guide to receive the inspection critique. The platoon commander exchanges salutes with the personage, permits the personage and host to pass in front of the platoon, faces to the left and commands **"Close Ranks, MARCH."** The platoon executes close ranks as described in enclosure 1, chapter 9, paragraph 18 and the platoon commander moves to a position six paces in front of, and centered on the platoon, halts, facing front, and goes to order sword.

(8) The inspecting party renders salutes as they pass in front of the colors, but not when passing to the rear of the colors.

(9) After completing the inspection of the platoon(s), the inspecting party passes around the rear of the formation and the right flank of the band. The commander of the honor guard executes a column left and moves to a position three paces in front of the right flank of the band and halts facing front. The personage receiving the honors halts in front of and facing the commander of the honor guard. Salutes are exchanged and the personage, host and other members of the inspecting party step off to their next position to receive the march in review. When the personage and the party have cleared his/her path, the commander of the honor guard steps off and returns to his/her post halts facing front and goes to order sword.

(10) The band stops playing.

j. If the personage does not desire to inspect, but merely to pass around the honor guard, the host, after the commander of the honor guard has reported **"Sir/Ma'am, the honor guard is formed,"** escorts the personage directly toward the right front of the band. The commander of the honor guard executes carry sword, faces to the right as in marching, and proceeds to a point where he/she joins the personage and host, and troops the line.

(1) The band begins playing.

(2) The order of precedence for the inspecting party, from left to right as they march down the line is: personage, host, and commander of the honor guard.

(3) The commander of the honor guard guides the personage along the front of the band, across the front of the honor guard between the front rank and platoon commanders.

(4) The inspecting party then passes along the left flank and rear of the honor guard and around the right flank of the band. The commander of the honor guard executes a column left and moves to a position three paces in front of the right flank of the band and halts facing front. The personage receiving the honors halts in front of and facing the commander of the honor guard. Salutes are exchanged and the personage, host and other members of the inspecting party step off to their next position to receive the march in review. When the personage and the party have cleared his/her path, the commander of the honor guard steps off and returns to his/her post, halts facing front and goes to order sword.

(5) The band stops playing.

k. If the personage desires the honor guard to pass in review only, or to pass in review following an inspection or pass around, he/she will command the commander of the honor guard to **"March the Guard in Review, Sir."**

(1) The commander of the honor guard executes carry sword, faces about and commands **"PASS IN REVIEW."** The band then changes direction on the line of march and halts.

(2) The commander of the honor guard then commands **"Right, FACE."** The guard executes. The platoon commanders go to carry sword and move to their position at the head of their platoons.

(3) The commander of the honor guard then commands **"Right Shoulder, ARMS."** The guard executes. The color guard goes to carry colors executes a right turn and halts.

(4) The commander of the honor guard then moves to a position behind the band and at the head of the column of troops formed by the guard.

(5) The commander of the honor guard then commands **"Forward, MARCH."** The band and guard step off simultaneously and marches in review. The commander of the honor guard salutes and executes eyes right without command, when six paces from the host and visiting personage, and without command terminates the salute and eyes right when 6 paces past the host and visiting personage.

(7) Platoon commanders give their platoons the command of **"Eyes, RIGHT"** when six paces from the host and visiting personage. Platoon commanders will give their platoons the command of **"Ready, FRONT"** when the last element of the platoon is 6 paces past the host and visiting personage.

(8) The drum major and the color guard execute eyes right and salute when six paces from the host and visiting personage and then execute ready front when six paces past the host and visiting personage.

(9) After the band has passed the position of the host and visiting personage the band executes three column left movements so as to position themselves in front of and facing the host and visiting personage and approximately 12 paces from the left flank of the marching units. The band continues to play and marches from the field following the last marching unit of the honor guard to pass in review.

(10) The commander of the honor guard, after passing in review, continues to march down the line of march and leads the honor guard from the field to a designated area and dismisses the guard.

l. If the personage does not desire to have the honor guard pass in review, the commander of the honor guard executes carry sword, faces about and commands **"Present, ARMS."** The honor guard executes present arms. The commander of the honor guard then faces the visiting personage and executes present sword. When the personage returns the salute the commander of the honor guard executes carry sword, faces the honor guard and commands **"Order, ARMS."** The honor guard goes to the order. The commander of the honor guard then faces the visiting personage and goes to order sword. The honor guard remains at attention until the visiting personage has departed. At that time the honor guard is dismissed.

m. The conduct of honor guard ceremonies as outlined above may be modified by commanders when the nature of the ground or exceptional circumstances require such changes.

n. Procedures for the conduct of a joint service honor guard will be as directed by the service commander charged with the conduct of the ceremony.

o. The conduct of honor guard ceremonies at Marine Barracks, Washington, DC. will be conducted as prescribed by the Commandant of the Marine Corps.

3. Rendering Honors to Personages Departing After Official Visits Ashore. Honors are rendered upon the departure of a personage entitled to honors in the same manner in which they were rendered upon arrival with the following exceptions:

a. Generally, if the personage inspected the honor guard upon arrival, the host advises him/her that another inspection on departure is not expected.

b. The honor guard will not pass in review.

c. Honors do not commence until the personage has completed their personal farewells.

d. If a gun salute is to be fired, it will begin just prior to the time the personage leaves the area where honors are rendered.

e. If a personal or foreign national flag has been flown during the visit, it will be hauled down upon the last note of musical honors, if no gun salute is fired, or when the last gun is fired.

4. Escorts of Honor

a. Escorts of honor are detailed to receive and escort civilian and military persons of high rank. Troops ordered to this duty are selected for their military appearance, bearing and superior discipline.

b. The escort is formed in line opposite the place where the person to be honored is to present himself/herself. The band forms on the flank of the escort in the direction toward which the escort is to march. The escort is brought to attention upon the appearance of the person to be honored. When he/she has taken the position from which he/she will receive the honors, the escort is brought to present arms, and honors due his/her rank are rendered. Upon completion of the honors, the escort is brought to order arms.

c. Ordinarily, the person so honored will, upon completion of the honors, inspect the escort. The escort then forms in column and takes up the march. The honored person with their staff or retinue, take position in the rear of the column. When the personage leaves the escort, the Marine again forms in line; and when he/she has taken position from which to receive them, honors are rendered as upon his/her arrival.

d. When the position of the escort is a considerable distance from the point where the person to be honored is received--where a court yard or wharf intervenes--a double line of sentries, facing inboard, is posted from that point to the escort. These sentries salute as the honored personage passes their individual positions. In this case, an officer is detailed to accompany the honored personage from the place of reception to the escort.

5. Additional Honors. For prescribed honors due vessels passing close aboard, dignitaries embarked in boats passing close aboard, and ships passing Washington's tomb, see reference (i).

6. Gun Salute

a. Organization

(1) The number of guns used will be per local Standing Operation Procedures (SOP).

(2) The size of the gun crew will be per local SOP.

b. Positioning the Gun for a Salute

(1) When selecting a position, ensure there is no flammable material in front of the gun line.

(2) Lay all howitzers on line.

(3) Ensure all personnel are kept a safe distance from the front of the gun line.

(4) Sight the gun line so that it points away from buildings and the ceremony area.

(5) Distance between howitzers will of course be dependent on space provided. However, optimum distance between howitzers is 12 paces.

(6) Weapons will be at "center-T" and cradle locking strut removed.

(7) Lunette will be in the up position.

c. Conduct of the Gun Salute

(1) At the proper time, the battery gunnery sergeant will march the battery on line three paces to the rear of the guns. Individual sections will not march past their respective gun. When the third gun is almost in position, the battery gunnery sergeant will give "**Mark Time, MARCH**" and "**Battery, HALT.**" While marking time, give the sections enough time to cover between their respective trails before giving "**HALT.**" After giving the battery "**HALT,**" the battery gunnery sergeant will face the battery opposite the direction of fire and receive the report from the section chief. Once the report has been given the battery gunnery sergeant will execute an about face and wait for the officer in charge/noncommissioned officer in charge to center himself/herself and receive the report.

Note: At this time, the battery gunnery sergeant should be standing at the actual center of the battery.

(2) The officer in charge/noncommissioned officer in charge and the timer will march on in the most direct manner to the battery gunnery sergeant. (Note: The timer's position is one pace to the left and one pace to the rear of the officer in charge/noncommissioned officer in charge. Use whatever supplementary drill procedures necessary to ensure that is where the Marine is when the officer in charge/noncommissioned officer in charge executes his/her facing movement to receive the report.) After the battery gunnery sergeant reports the battery is formed, the officer in charge/noncommissioned officer in charge commands "**TAKE YOUR POST.**" The battery gunnery sergeant will move one pace to the right (opposite the timer) and one pace to the rear of the officer in charge/noncommissioned officer in charge. The battery gunnery sergeant will then face in the same direction as the officer in charge/noncommissioned officer in charge. (The direction of fire.) After the officer in charge/noncommissioned officer in

charge, timer and battery gunnery sergeant are in place they are commanded as the **"Staff"** (**"Staff, ATTENTION;" "Staff, Parade, REST;" etc.**). At this time all commands are coming from the officer in charge/noncommissioned officer in charge.

(3) The officer in charge/noncommissioned officer in charge commands **"POST,"** at this time the sections will execute an about face. The officer in charge/ noncommissioned officer in charge then commands **"MARCH,"** and all sections will march in the most direct manner to their respective positions. Once the Marines are in place, still facing in the direction of fire, the section chiefs in gun order will command **"Ready, FACE."** The Marines face inboard.

(4) The officer in charge/noncommissioned officer in charge commands **"LOAD"** and the loader will load a round. The breeches will be closed in gun order and the loader then comes back to the position of attention.

Note: This only occurs on the first round, after that loading will occur as quickly as possible.

(5) If there is a substantial amount of time, the officer in charge/ noncommissioned officer in charge may give **"Parade, REST."** When *"Ruffles and Flourishes"* is sounded the crew must be at attention.

(6) On the last note of *"Ruffles and Flourishes,"* the first round is fired. The timer starts the stopwatch on the first round. For most salutes, rounds must be fired every five seconds. That means on every five-second mark a round must sound. In order for this to happen you must compensate. The officer in charge/non-commissioned officer in charge may either use hand and arm signals to fire each weapon or use verbal commands (e.g.; Drop of the arm or **"NUMBER, FIRE."**) When using the verbal command, do not use the traditional "Stand-by Fire" use **"NUMBER, FIRE."** Normally the timer must command **"TIME"** every three seconds after a round has fired. To make this easy, use every 3, 8, 13, 18, 23, 28, 33, 38, etc, seconds. It is on these seconds the timer would command **"TIME"** to have a round go off at 5, 10, 15, 20, 25, 30, 35, 40, etc., seconds.

(7) After firing a round, loading is automatic. Loader will keep loading until rounds stop firing. This is in case of a misfire. The procedure for loading is as follows; the section chief will fire the round and open the breech, the loader will catch the sleeve with the right hand give it to the ammo man and at the same time receive a prepared round from the ammo man and load it. The cycle is continuous.

(8) It is the responsibility of the battery gunnery sergeant to count each round to ensure the proper amount of rounds is fired. The battery gunnery sergeant will, at a normal tone, count out loud to the officer in charge/noncommissioned officer in charge every round as well as marking them on a piece of paper. After the second to last round, the Marine will command to the battery **"LAST ROUND."**

(9) After the last round is fired the officer in charge/noncommissioned officer in charge will command **"Battery, Hand, SALUTE"** or **"Staff, Hand, SALUTE,"** and **"Staff, Ready TWO"** or **"Battery, Ready TWO."** After the hand salute, the officer in charge/noncommissioned officer in charge commands **"UNLOAD."** All breeches are cleared using the unloading procedure discussed above.

(10) After unloading is complete, the officer in charge/noncommissioned officer in charge commands "**POST,**" the battery Marines do whatever movement necessary to face opposite the direction of fire. Then the officer in charge/noncommissioned officer in charge commands "**MARCH,**" the battery Marines march back to their original three paces behind the gun line.

(11) The officer in charge/noncommissioned officer in charge calls the battery gunnery sergeant to "**Center,**" and turns the battery over to the Marine. The officer in charge/noncommissioned officer in charge then faces and leaves the area in the most direct manner.

(12) Then the battery gunnery sergeant will either dismiss the battery or march them off in the most direct manner.

Note: Sometimes the battery will perform in conjunction with the ceremony and everyone may have to remain in position until the ceremony is over. When the battery is actually part of the ceremony, and there is more of the ceremony to be conducted after the gun salute, the officer in charge/noncommissioned officer in charge will wait until the ceremony is concluded to march off.

d. Jams and Misfires

(1) If a weapon jams or misfires, that weapon is out of action for the rest of the ceremony. The ammo man of that gun will evenly distribute that gun's ammunition smartly and quickly. After the ammunition is distributed, the ammo man will return to his/her position on the gun.

(2) When a weapon jams or misfires during a ceremony, it is now time to fall on your training. When the jam or misfire occurs, the section chief will command "**MISFIRE.**" As soon as the next section chief hears "**MISFIRE**", the Marine will fire without command. This must be done quickly to make up for any lost time.

7. Honors for Official Visits of United States Officers

Table 10-1.--Honors Matrix.

Officer	Uniform	Gun Salute		Ruffles and Flourishes	Music	Guard	Side Boys
		Arri	Departure				
Chairman, Joint Chiefs of Staff	Full Dress	19	19	4	General's or Admiral's March	Full	8
Chief of Staff, U.S. Army	Full Dress	19	19	4	General's March	Full	8
Chief of Naval Operation	Full Dress	19	19	4	Admiral's March	Full	8
Chief of Staff, U.S. Air Force	Full Dress	19	19	4	General's March	Full	8
Commandant of the Marine Corps	Full Dress	19	19	4	Admiral's March	Full	8
Commandant of the Coast Guard	Full Dress	19	19	4	Admiral's March	Full	8
General of the Army	Full Dress	19	19	4	General's March	Full	8
Fleet Admiral	Full Dress	19	19	4	Admiral's March	Full	8
General of the Air Force	Full Dress	19	19	4	General's March	Full	8
Generals	Full Dress	17	17	4	General's March		8
Admirals	Full Dress	17	17	4	Admiral's March	Full	8
Naval or other military governor, commissioned as such by the President within the area of	Full Dress		17	4	General's or Admiral's March	Full	8
Vice Admiral or Lieutenant General	Full Dress		15	3	General's or Admiral's March	Full	8
Rear Admiral or Major General	Full Dress		13	2	General's or Admiral's March	Full	6
Rear Admiral (lower half) or Brigadier General	Full Dress		11	1	General's or Admiral's March	Full	6

Chapter 11

Marine Corps Birthday Cake Cutting Ceremony

TABLE OF CONTENTS

<u>IDENTIFICATION</u>	<u>TITLE</u>	<u>PAGE</u>
1.	General.....	11-2
2.	Sequence of Events for the March on.....	11-2
3.	Reading the Messages and Cutting the Cake.....	11-11
4.	Sequence of Events for the March Off and Conclusion of the Ceremony.....	11-13
5.	Variations.....	11-17
6.	Recommended Personnel Assignments.....	11-18
Figure 11-1	Participants Staged.....	11-2
Figure 11-2	Music's Movements.....	11-3
Figure 11-3	Adjutant, Drummers and Trumpeters Movements.....	11-5
Figure 11-4	March on of General Officers and Escorts.....	11-6
Figure 11-5	Movements of the Commanding General (Or Commanding Officer) and Guest of Honor.....	11-7
Figure 11-6	Movements of the Color Guard.....	11-9
Figure 11-7	Movements of the Cake.....	11-10
Figure 11-8	Moving the Cake in Order to Clear the Line of March.....	11-14
Figure 11-9	March Off of Color Guard, Commanding General, Guest of Honor and General Officers.....	11-15
Figure 11-10	Movements of the Escorts During the March Off.....	11-16
Figure 11-11	Movements of the Drummers and Trumpeters During the March Off.....	11-17

Chapter 11

Marine Corps Birthday Cake Cutting Ceremony

1. General. The following procedure is prescribed as a guide for the conduct of the Marine Corps Birthday Cake Cutting Ceremony. It is outlined on the basis of a Marine Corps post commanded by a General Officer. At posts where no General Officer is present, and at staff noncommissioned officer, enlisted or unit balls, modifications may be made as necessary to meet local conditions. Rehearsals must be conducted to ensure that the ceremony proceeds smoothly and precisely.

2. Sequence of Events for the March On

a. H-Hour-15 Minutes. All participants in the ceremony are formed at the entrance to the ballroom. (See figure 11-1.) All bars, if any, will close.

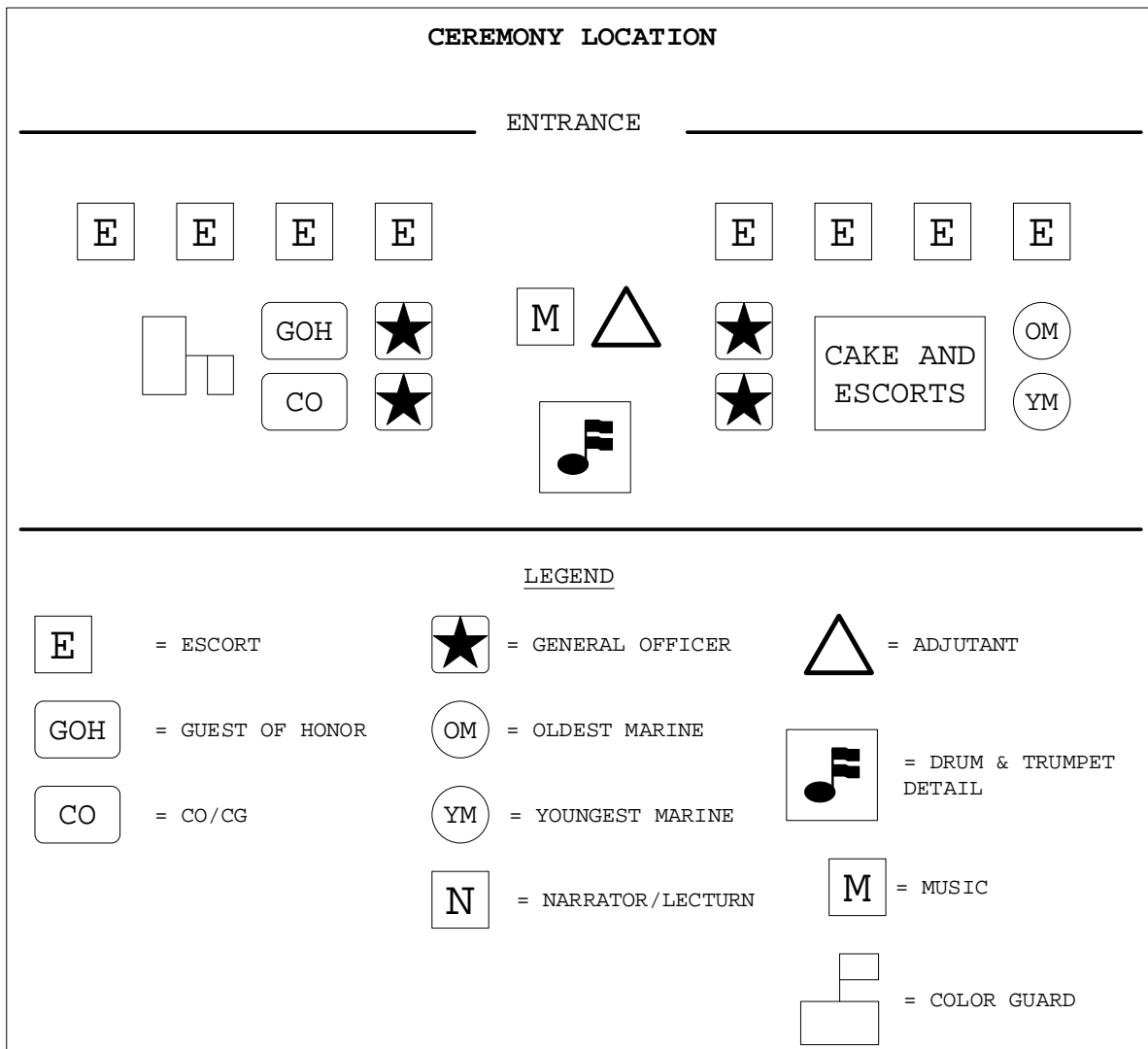

Figure 11-1.—Participants Staged.

b. H-Hour-5 Minutes

(1) Bugler moves to position centered on the dance floor and sounds "Attention," followed by "Officers Call" (or "First Sergeant's Call" at staff noncommissioned officer/enlisted balls) and then departs the floor and returns to a position with the drummers and trumpeters. (See figure 11-2.)

(2) The escorts draw swords and go to parade rest.

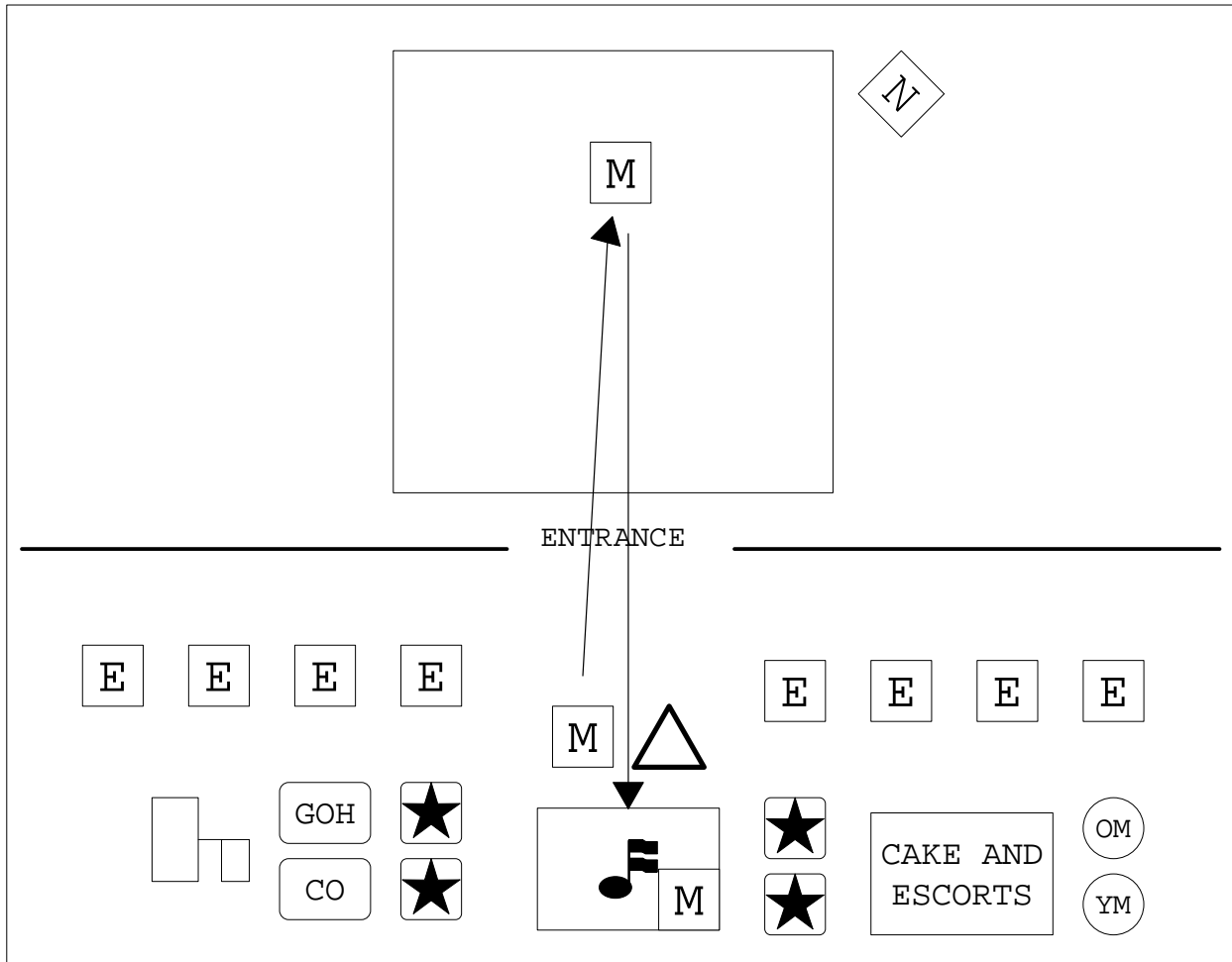

Figure 11-2.--Music's Movements.

Note: As an option; the CMC/SMMC Birthday message video may be played before the start of the ceremony.

NARRATOR: "LADIES AND GENTLEMEN, PLEASE BE SEATED AS THE CEREMONY IS ABOUT TO BEGIN."

NARRATOR: "GOOD EVENING LADIES AND GENTLEMEN, WELCOME TO THE UNITS NAME BALL CELEBRATING THE # OF BIRTHDAY (e.g., 244th) BIRTHDAY OF OUR CORPS. (INVOCATION OPTIONAL) PLEASE RISE AS NAME OF CHAPLAIN DELIVERS THE INVOCATION."

Chaplain delivers the invocation.

NARRATOR: "LADIES AND GENTLEMEN, PLEASE DIRECT YOUR ATTENTION TO THE (LOCATION, EX. "LEFT OF THE STAGE"), YOU WILL FIND AN ILLUMINATED TABLE THAT HAS BEEN PREPARED IN HONOR OF OUR FALLEN COMRADES. IT SYMBOLIZES THE VALIANT SACRIFICES OF OUR MARINE CORPS-NAVY TEAM. TONIGHT, WE PAY SPECIAL TRIBUTE TO THE MEMBERS OF OUR MARINE CORPS FAMILY WHO HAVE BEEN TAKEN FROM US. THEIR SACRIFICES, AND THE SACRIFICES OF THEIR FAMILIES, HELP PRESERVE OUR NATION'S FREEDOM AND ENABLE MILLIONS OF OUR CITIZENS TO ENJOY THE AMERICAN DREAM. WE STAND FREE TODAY BECAUSE OF THEM. LADIES AND GENTLEMEN, PLEASE JOIN IN A MOMENT OF SILENCE AS WE PAUSE TO HONOR THOSE BRAVE MEN AND WOMEN WHO HAVE GIVEN THEIR LIVES IN THE SERVICE OF OUR COUNTRY."

c. H-Hour. The adjutant moves to a position at the far end of the dance floor from the entrance, halts faces the entrance, and draws sword. (See figure 11-3.)

d. Adjutant commands "SOUND ATTENTION." Drum and trumpet detail sounds "Attention." Escorts execute attention without command.

e. Adjutant commands "SOUND ADJUTANT'S CALL." Drum and trumpet detail sounds "Adjutant's Call."

(1) Immediately after "Adjutants Call," the drum and trumpet detail plays "French Foreign Legion." Drum and trumpet detail marches down a cleared lane to the far end of the dance floor, countermarches in front of the adjutant, and followed by the adjutant, marches back to the main entrance, countermarches again, and halts. Drum and trumpet detail then moves sufficient distance left or right to clear the entrance doorway.

Note: If the ballroom is too small for the drum and trumpet detail to remain on the dance floor, or if they are part of the main band, then they would march off the dance floor.

(2) The adjutant moves to a position behind the cake. The march is ceased on command of the drum major. (See figure 11-3.)

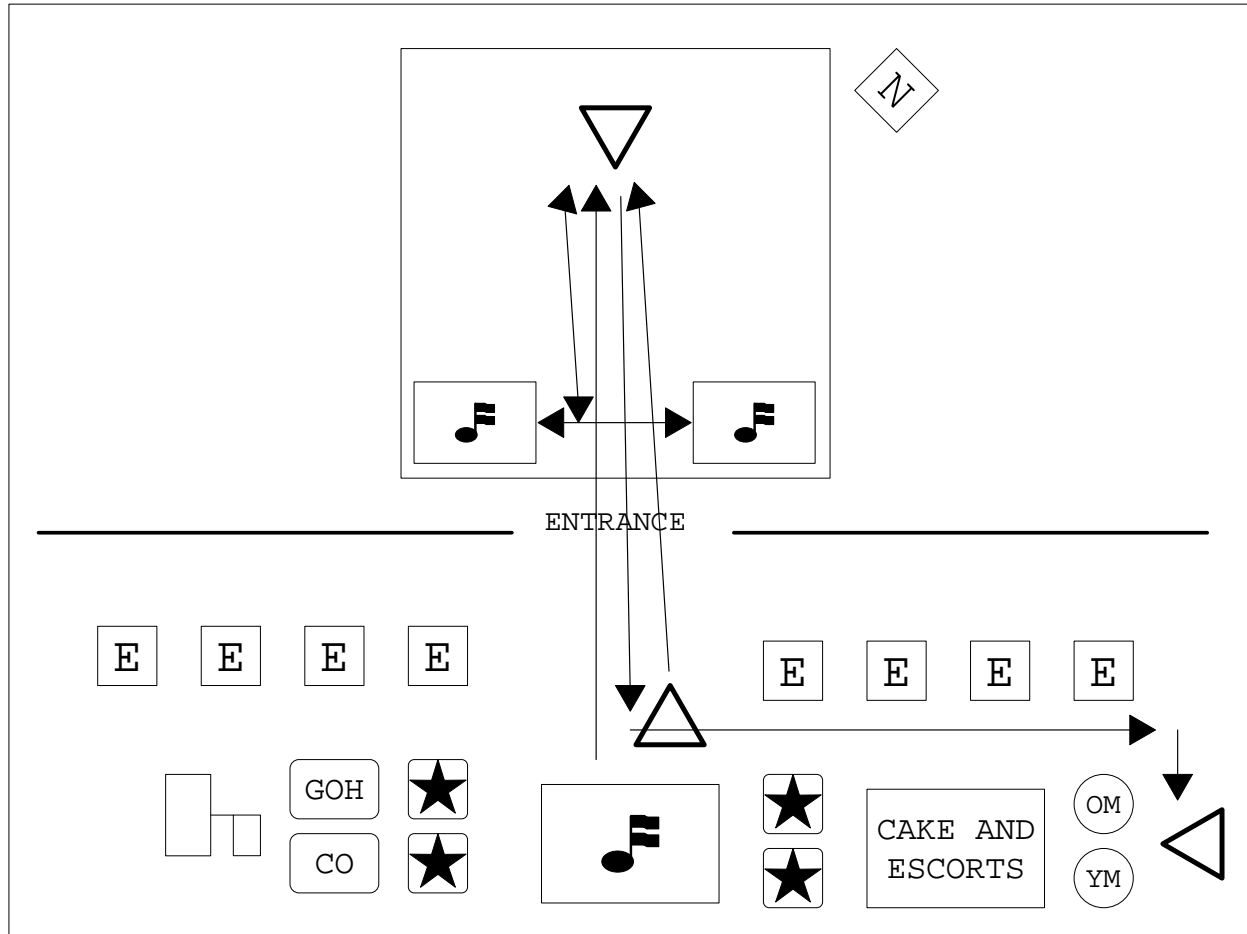

Figure 11-3.--Adjutant, Drummers and Trumpeters Movements.

f. Senior escort commands **"Forward, MARCH."**

(1) Band commences playing *"Semper Fidelis."*

(2) The two senior escorts (1st pair) enter the ball room together and march to their position at the far end of the dance floor, halt, face outboard, march forward to their position (4-8 paces) halt, face about and go to order swords.

(3) The remainder of the escorts step off by twos (2nd pair, 3d pair, etc.) from senior to junior, at 4-pace intervals and move to their position on the dance floor in the same manner as the lead escorts, the two lines forming the two long sides of a hollow rectangle. (See paragraph 6 of this chapter for the recommended composition of escorts.)

(4) Once all escorts are in position and at order sword, General Officers, if present, enter the ball room in pairs from the main entrance, march down the line of escorts to their position at the far end of the dance floor, halt and face the entrance thus forming the third side of the rectangle.

(5) Two spaces are left open in the center of the line of General Officers. When all are in position, the band stops playing. (See figure 11-4.)

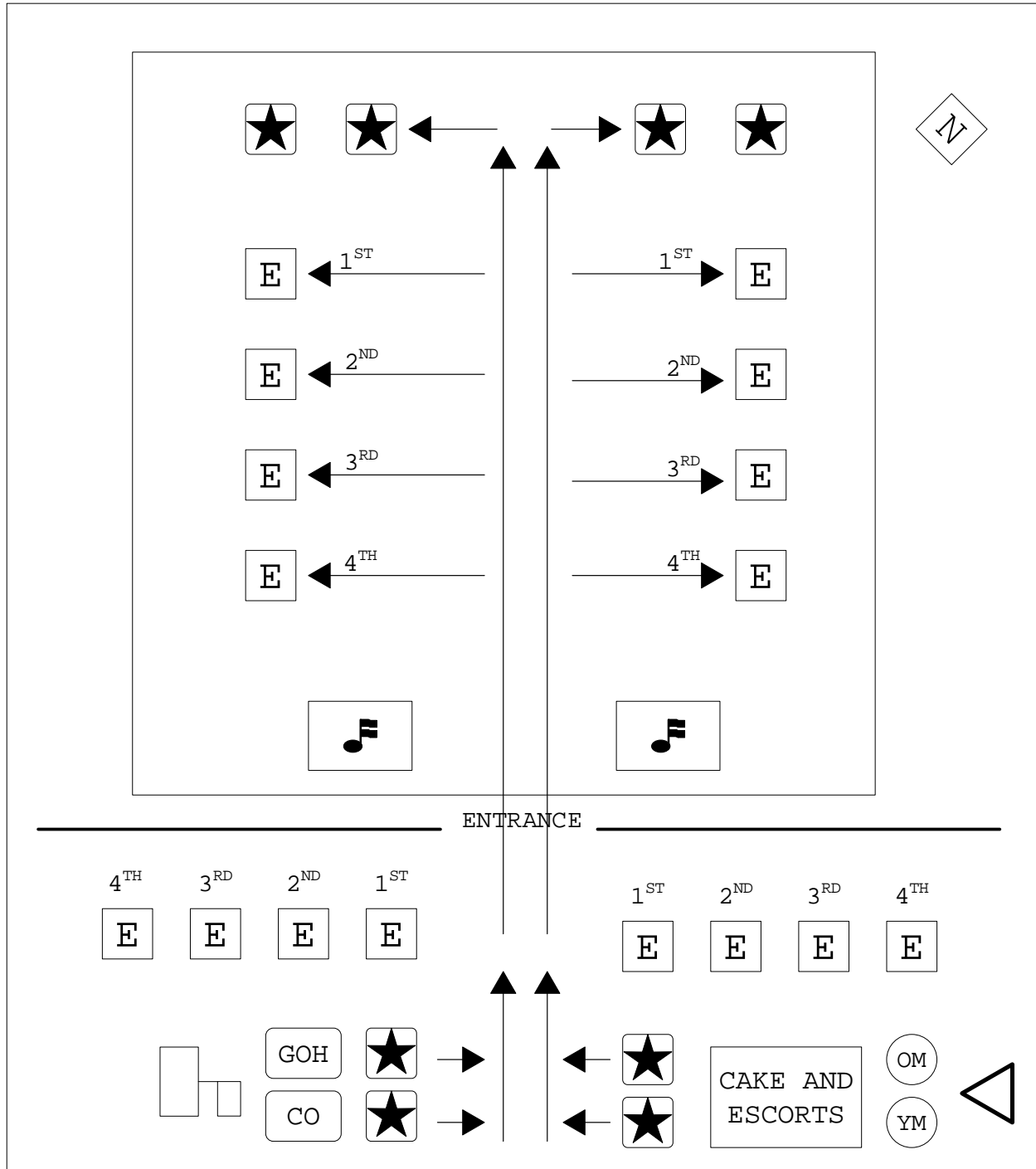

Figure 11-4.--March on of General Officers and Escorts.

(6) Band sounds "Attention." The Commanding General (see note) and the guest of honor enter the ballroom together and move to a position centered between the line of escorts and halt. (See figure 11-5.)

NARRATOR: "LADIES AND GENTLEMEN, PLEASE RISE FOR HONORS TO THE COMMANDING GENERAL (GUEST OF HONOR AND COMMANDING OFFICER) AND REMAIN STANDING FOR THE PRESENTATION OF THE COLORS."

Note: At a ball where neither the guest of honor nor the escort rate musical honors, then the narrator makes the above statement, but no musical honors are rendered. The escorts simply "Present, ARMS." In this case, the line of General Officers would be omitted.

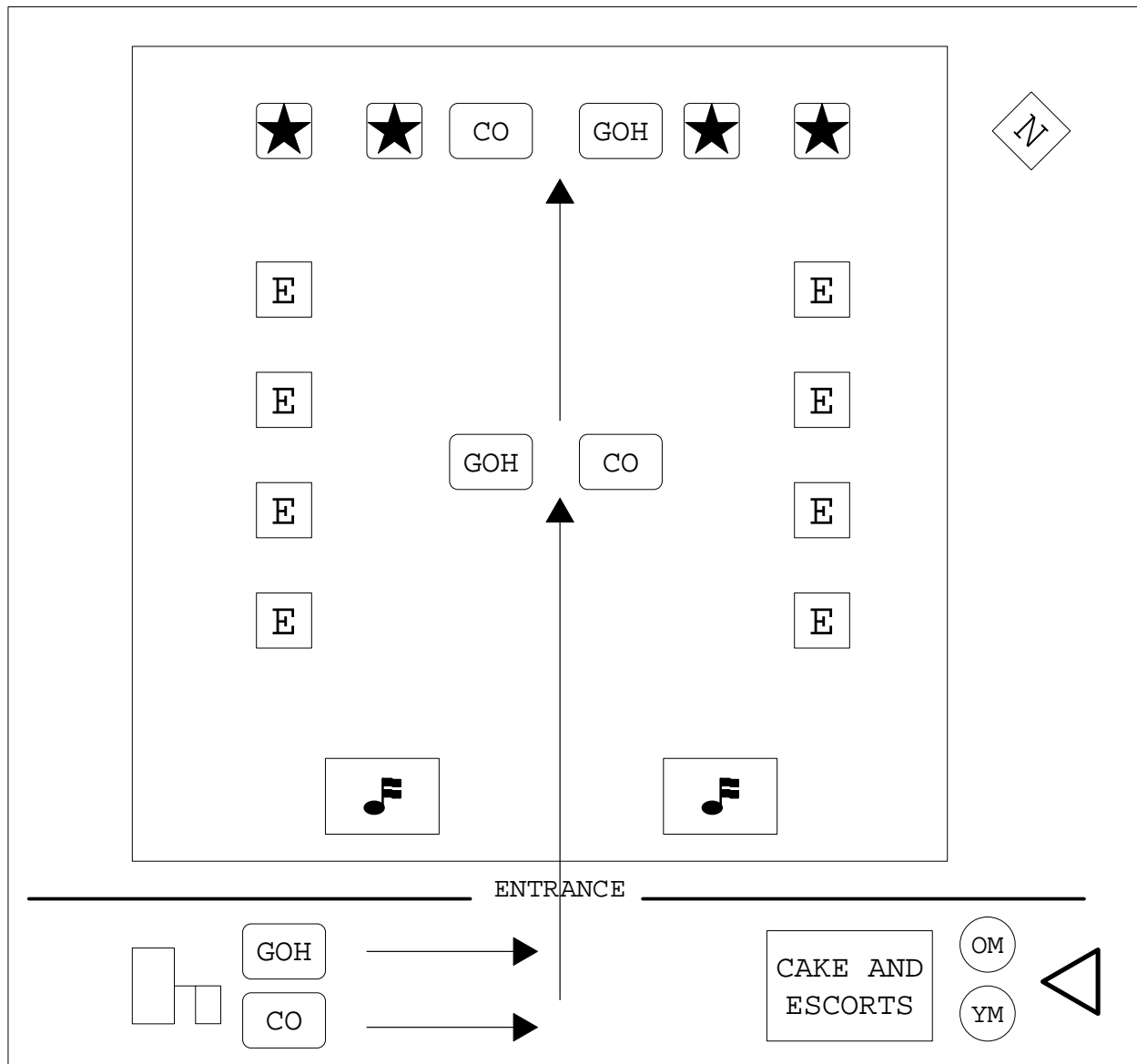

Figure 11-5.--Movements of the Commanding General (or Commanding Officer) and Guest of Honor.

Note: The commanding officer will march in to the right of the guest of honor, regardless of rank.

g. The senior escort commands "**Present, SWORD.**" The escorts execute present sword. The band plays appropriate musical honors. The commanding general (or commanding officer) and the guest of honor return the salute if covered. After the last note of honors, the Commanding General (or commanding officer) and guest of honor terminate their salute.

h. The senior escort commands "**Order, SWORD.**" The escorts execute order sword. The Commanding General (or commanding officer) and guest of honor move to their positions in the line of General Officers, halt and face about. (See figure 11-5.) When both are in position.

i. Band sounds "*Attention.*" The color guard enters the ballroom at the carry and marches to a point halfway down the line of escorts, halts and remains at the carry (see figure 11-6).

j. The senior escort commands "**Present, SWORD.**" The escorts present sword.

(1) Commanding General (or commanding officer), guest of honor and General Officers, if covered, salute on the first note of the music.

(2) The color guard riflemen execute present arms from the carry on the command of present sword by the senior escort. The band then plays the "*National Anthem.*" The organizational colors presents on the first note of the music and returns to the carry on the last note. The color guard riflemen execute shoulder arms on the command of order arms by the senior escort.

(3) Commanding General (or commanding officer), guest of honor and General Officers, if covered, cut their salute on the last note of the music.

k. The senior escort commands "**Order, SWORD.**" The escorts order sword.

(1) The color guard riflemen return to the carry. The color guard then marches forward to the far end of the dance floor, countermarches and marches back down the line of escorts to their position by the main entrance, countermarches, halts and goes to the order. The color guard then separates by executing sufficient left and right steps for the cake and escorts to enter the ballroom. (See figure 11-6.) Once the color guard is in position.

<p>NARRATOR: "LADIES AND GENTLEMEN, PLEASE REMAIN STANDING FOR THE ENTRANCE OF THE TRADITIONAL MARINE CORPS BIRTHDAY CAKE."</p>
--

(2) Band sounds "*Attention.*"

(3) The band then plays the "*Marines Hymn*" (slow version) and the cake escorts (see paragraph 6.c. of this chapter for the recommended composition of the cake escorts) enter the ballroom. Between them, they push a serving cart on which are placed the birthday cake, a Marine sword (officer or noncommissioned officer), two plates, three forks and napkins. The oldest and youngest Marine present, and adjutant follow the cake. The escorts slowly roll the cake to a position in front of the Commanding General (or commanding officer), halt, take one side step and face inboard

toward the cake. (See figure 11-7.) The band stops playing.

NARRATOR: "LADIES AND GENTLEMEN, PLEASE BE SEATED."

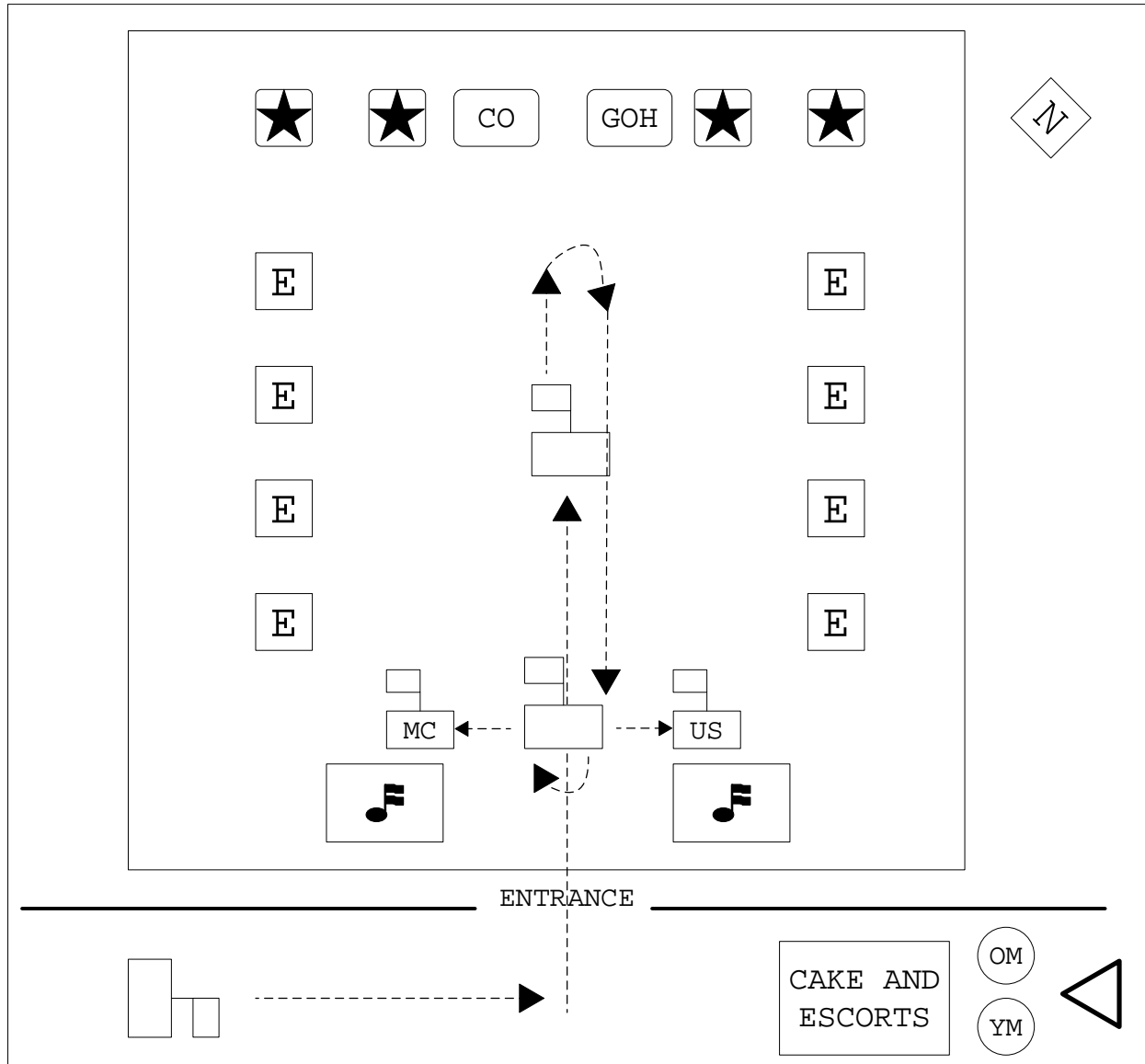

Figure 11-6.--Movements of the Color Guard.

1. The senior escort commands "**Parade, REST.**" All escorts, cake escorts, color guard, band, General Officers and guest of honor execute.

(1) The adjutant remains at attention, faces about goes to order sword, and moves the sword into the position for reading documents described in enclosure 1, chapter 5. The adjutant carries the scroll under the left arm in the same manner as a cased sword would be carried.

(2) The adjutant then unfurls the scroll containing General Lejeune's Message and prepares to read it after the narrator has read the introductory statement.

Note: In particularly large formations or facilities where the adjutant may be hard to hear and/or a wireless microphone is not available, the narrator may read General Lejeune's Message. In that case, the adjutant would remain at carry sword during the reading of the message.

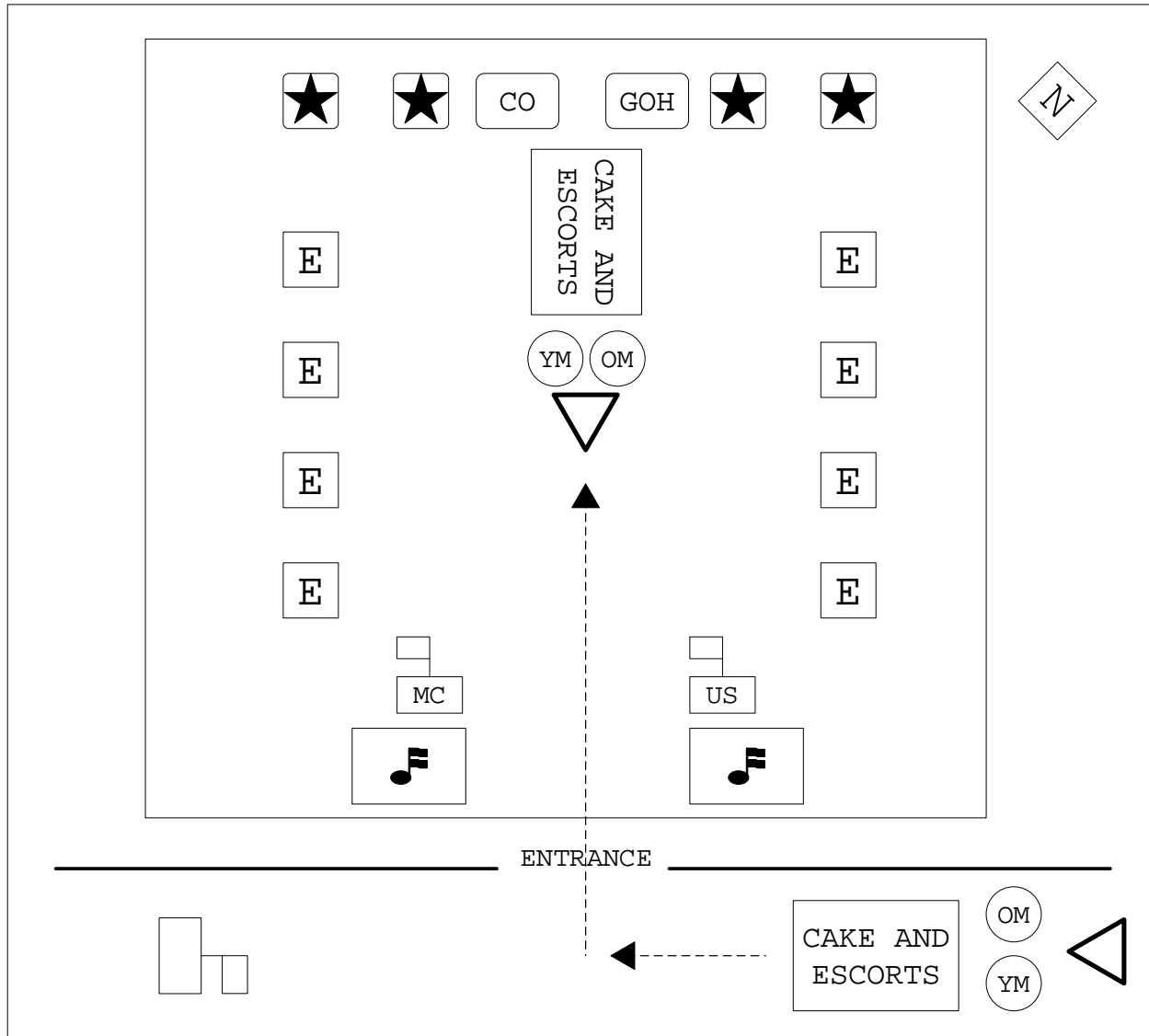

Figure 11-7.--Movements of the Cake.

3. Reading the Messages and Cutting the Cake

a. The narrator begins this portion of the ceremony by reading the introductory statement to General Lejeune's traditional birthday message.

NARRATOR: "ON ONE NOVEMBER 1921, THE 13TH COMMANDANT OF THE MARINE CORPS, LIEUTENANT GENERAL JOHN A. LEJEUNE, DIRECTED THAT A REMINDER OF THE HONORABLE SERVICE OF THE CORPS BE PUBLISHED BY EVERY COMMAND TO ALL MARINES THROUGHOUT THE GLOBE, ON THE BIRTHDAY OF THE CORPS. SINCE THAT DATE, MARINES HAVE CONTINUED TO DISTINGUISH THEMSELVES ON MANY BATTLEFIELDS AND FOREIGN SHORES, IN WAR AND PEACE. ON THIS BIRTHDAY OF THE CORPS, THEREFORE, IN RECOGNITION OF THE WILL OF THE 13TH COMMANDANT, A REMINDER OF THE CORPS' HONORABLE SERVICE IS PUBLISHED AS FOLLOWS:"

ADJUTANT/NARRATOR:

"ON NOVEMBER 10TH, 1775, A CORPS OF MARINES WAS CREATED BY A RESOLUTION OF THE CONTINENTAL CONGRESS. SINCE THAT DATE, MANY THOUSAND MEN HAVE BORE THE NAME MARINE. IN MEMORY OF THEM IT IS FITTING THAT WE WHO ARE MARINES SHOULD COMMEMORATE THE BIRTHDAY OF OUR CORPS BY CALLING TO MIND THE GLORY OF ITS LONG AND ILLUSTRIOUS HISTORY.

THE RECORD OF OUR CORPS IS ONE WHICH WILL BEAR COMPARISON WITH THAT OF THE MOST FAMOUS MILITARY ORGANIZATIONS IN THE WORLD'S HISTORY. DURING 90 OF THE FIRST 146 YEARS OF ITS EXISTENCE, THE MARINE CORPS HAS BEEN IN ACTION AGAINST THE NATION'S FOES. FROM THE BATTLE OF TRENTON TO THE ARGONNE, MARINES HAVE WON FOREMOST HONORS IN WAR, AND IN THE LONG ERAS OF TRANQUILLITY AT HOME. GENERATION AFTER GENERATION OF MARINES HAVE GROWN GRAY IN WAR, IN BOTH HEMISPHERES, AND IN EVERY CORNER OF THE SEVEN SEAS, THAT OUR COUNTRY, AND ITS CITIZENS MIGHT ENJOY PEACE AND SECURITY.

IN EVERY BATTLE AND SKIRMISH SINCE THE BIRTH OF OUR CORPS, MARINES HAVE ACQUITTED THEMSELVES WITH THE GREATEST DISTINCTION, WINNING NEW HONORS ON EACH OCCASION UNTIL THE TERM MARINE HAS COME TO SIGNIFY ALL THAT IS HIGHEST IN MILITARY EFFICIENCY AND SOLDIERLY VIRTUE.

THIS HIGH NAME OF DISTINCTION AND SOLDIERLY REPUTE, WE WHO ARE MARINES TODAY, HAVE RECEIVED FROM THOSE WHO HAVE PRECEDED US IN THE CORPS. WITH IT, WE ALSO RECEIVED FROM THEM THE ETERNAL SPIRIT WHICH HAS ANIMATED OUR CORPS FROM GENERATION TO GENERATION AND HAS BEEN THE DISTINGUISHING MARK OF MARINES IN EVERY AGE. SO LONG AS THE SPIRIT CONTINUES TO FLOURISH, MARINES WILL BE FOUND EQUAL TO EVERY EMERGENCY IN THE FUTURE AS THEY HAVE BEEN IN THE PAST, AND THE MEN OF OUR NATION WILL REGARD US AS WORTHY SUCCESSORS TO THE LONG LINE OF ILLUSTRIOUS MEN WHO HAVE SERVED AS "SOLDIERS OF THE SEA" SINCE THE FOUNDING OF THE CORPS."

b. The adjutant, without command, then puts away the scroll, returns to carry sword and exits the ballroom. Once clear of the ballroom, the adjutant returns sword, this completes his/her portion of the ceremony.

NARRATOR: "THE TIMELESS AND INSPIRING MESSAGE OF OUR 13TH COMMANDANT HAS LEFT ITS MARK IN THE HEARTS AND MINDS OF ALL MARINES, PAST AND PRESENT. BY DEED AND ACT FROM BELLEAU WOOD TO THE ARGONNE, FROM GUADALCANAL TO IWO JIMA, FROM INCHON TO THE KOREAN ARMISTICE, FROM THE HARD FIGHTS IN VIETNAM TO DESERT SHIELD/DESERT STORM TO THIS CENTURY'S LONGEST WARS IN IRAQ AND AFGHANISTAN, AND IN HUNDREDS OF OTHER PLACES WHERE MARINES HAVE DISTINGUISHED THEMSELVES. MARINES HAVE CONTINUED TO EPITOMIZE THOSE QUALITIES WHICH ARE THEIR LEGACY. THE SUCCESS WHICH THE MEN AND WOMEN WHO HAVE EARNED THE TITLE MARINE HAVE ACHIEVED IN COMBAT AND THE FAITH THEY HAVE BORNE IN PEACE WILL ENDURE FOREVER. THE COMMANDANT AND OUR MANY FRIENDS HAVE ADDED THEIR HEARTY PRAISE AND CONGRATULATIONS ON THIS, OUR _____ BIRTHDAY."

NARRATOR: "LADIES AND GENTLEMEN, A MESSAGE FROM THE COMMANDANT OF THE MARINE CORPS." (text inserted here)

Note: this message may be added to the ceremony's programs.

c. After the messages are read, the Commanding General and guest of honor move to the cake.

d. The oldest and youngest Marine move to position on the side of the cake nearest to the Commanding General. As the Commanding General approaches the cake, the senior cake escort steps forward, takes the sword from the cake cart and delivers it to the Commanding General by passing it over the left forearm, grip toward the Commanding General. (See enclosure 1, chapter 5, paragraph 18.)

e. As the Commanding General cuts the cake, the band begins playing "*Auld Lang Syne*."

f. Assistance is rendered by the cake escorts in placing the pieces on the plate.

g. The first piece is given to the guest of honor who takes a bite and returns the plate to the cake escort.

h. The second piece is placed on a plate with two forks and given to the oldest Marine who takes a bite and passes the piece to the youngest Marine who takes a bite. The youngest Marine then returns the plate to a cake escort who places it back on the serving cart.

i. While the cake is being cut and presented, the narrator reads:

NARRATOR: "THE MARINE CORPS BIRTHDAY CAKE CUTTING CEREMONY IS IMPORTANT TO ALL MARINES AS IT IS AN ANNUAL RENEWAL OF EACH MARINE'S COMMITMENT TO THE CORPS, AND THE CORPS' COMMITMENT TO OUR NATION'S QUEST FOR PEACE AND FREEDOM WORLDWIDE. THE BIRTHDAY CAKE IS TRADITIONALLY CUT WITH THE MAMELUKE SWORD AS A REMINDER THAT WE ARE A BAND OF WARRIORS COMMITTED TO CARRYING THE SWORD SO THAT OUR NATION MAY LIVE IN PEACE. AS IS OUR CUSTOM, THE FIRST PIECE OF CAKE WILL BE PRESENTED TO OUR GUEST OF HONOR, (RANK/TITLE, LAST NAME). BY TRADITION, THE NEXT PIECE OF CAKE IS PRESENTED TO THE OLDEST MARINE IN ATTENDANCE, AS A SIGN OF HONOR AND RESPECT ACCORDING TO EXPERIENCE AND SENIORITY. THIS EVENING OUR OLDEST MARINE IS (RANK/FULL NAME), WHO ENLISTED/WAS COMMISSIONED IN THE MARINE CORPS ON (DATE). A NATIVE OF (CITY, STATE) AND (RANK/LAST NAME) WAS BORN ON (DAY/MONTH/YEAR). FOR _____ YEARS, OUR EXPERIENCED MARINES HAVE NURTURED AND LED YOUNG MARINES TO FILL OUR RANKS AND RENEW OUR CORPS. THE OLDEST MARINE PASSES THE PIECE OF CAKE TO THE YOUNGEST MARINE, SYMBOLIZING THE PASSING OF WISDOM, KNOWLEDGE, AND EXPERIENCE AS WELL AS TRUST AND CONFIDENCE IN THOSE WHO WILL CARRY ON OUR MARINE CORPS TRADITIONS IN THE FUTURE. THIS EVENING, OUR YOUNGEST MARINE IS (RANK/FULL NAME) WHO ENLISTED/WAS COMMISSIONED IN THE MARINE CORPS ON (DATE) AND REPORTED FOR DUTY HERE AT (BASE/POST) ON (DATE), CURRENTLY SERVING WITH (COMPANY/UNIT). A NATIVE OF (CITY, STATE), (RANK/LAST NAME) WAS BORN ON (DAY/MONTH/YEAR)."

j. After the youngest Marine has tasted and returned the cake, the Commanding General, guest of honor, oldest Marine and youngest Marine return to their positions.

4. Sequence of Events for the March Off and Conclusion of the Ceremony

a. The march off is begun by moving the cake from in front of the line of General Officers to a position out of the line of march. Once the oldest and youngest Marines are in position, the cake escorts take one-step forward face left or right and re-grasp the cake cart. The senior cake escort then quietly commands the cake escorts, oldest and youngest Marines to "**Forward, MARCH,**" and moves the cake detail from the dance floor in order to clear the way for the march off. (See figure 11-8.) The cake escorts, and oldest and youngest Marines then face towards the entranceway and remain in position.

b. The senior escort commands, "**Detail, ATTENTION.**" Detail executes. The color guard begins the march off by side stepping back to close interval and going to carry colors. (See figure 11-9.)

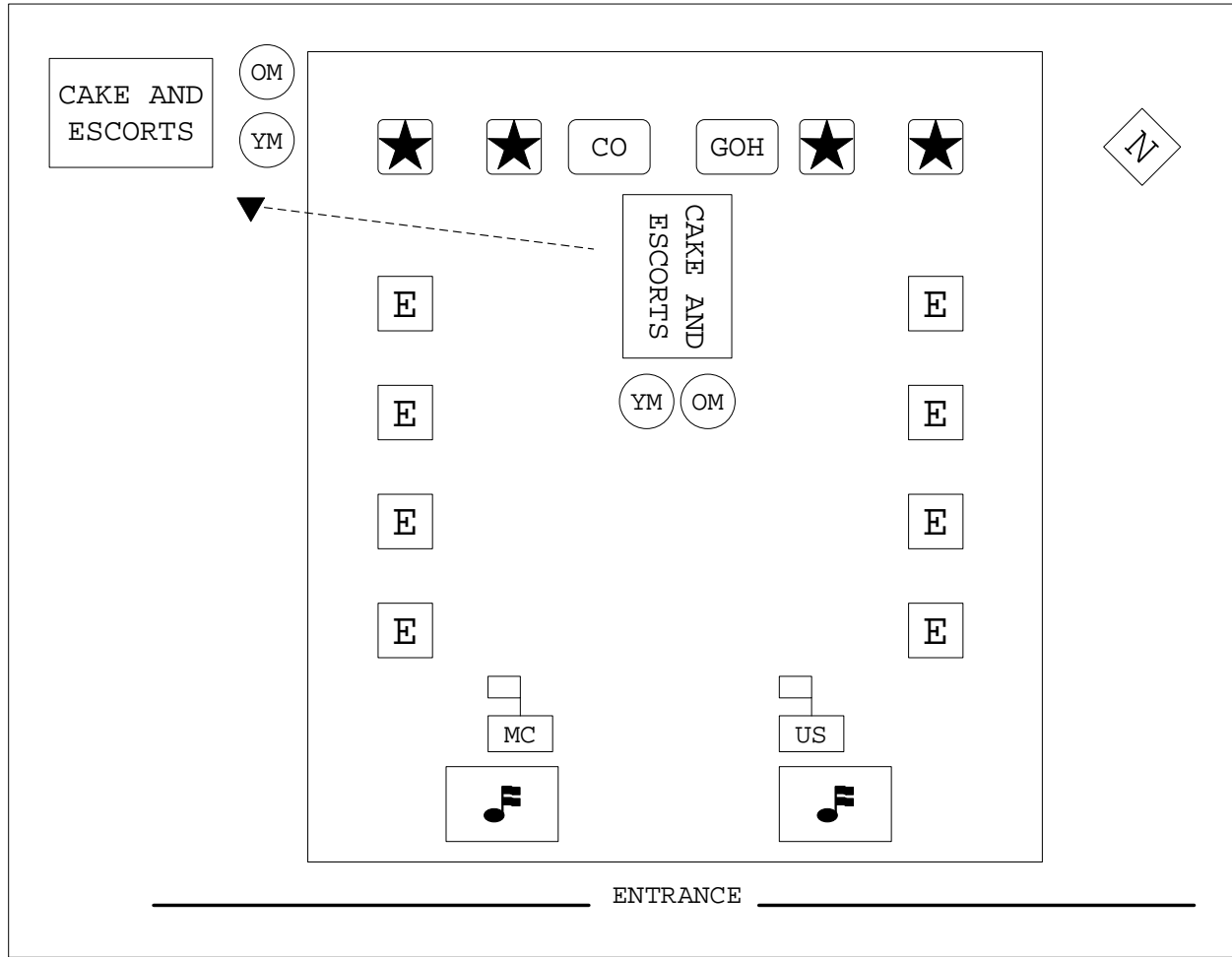

Figure 11-8.--Moving the Cake in Order to Clear the Line of March.

NARRATOR: "LADIES AND GENTLEMEN, PLEASE RISE FOR THE RETIREMENT OF THE COLORS AND THE DEPARTURE OF THE OFFICIAL PARTY, WHICH WILL BE FOLLOWED BY THE PLAYING OF ANCHORS' AWEIGH AND THE MARINES' HYMN."

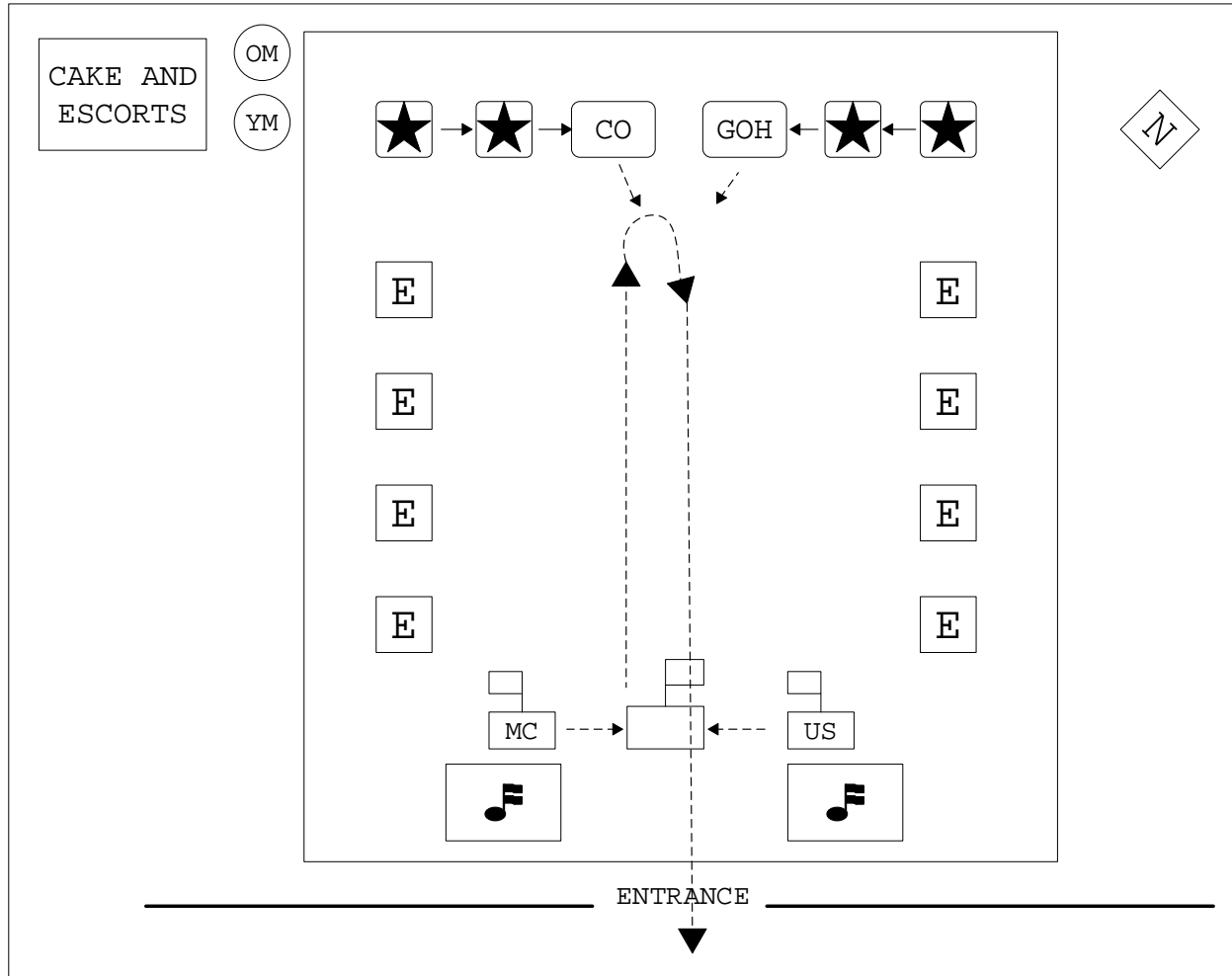

Figure 11-9.--March Off of Color Guard, Commanding General, Guest of Honor and General Officers.

- c. The senior escort commands **"Present, SWORD."** The escorts execute.
- d. The color sergeant commands **"Forward, MARCH."**
 - (1) The band begins playing *"Semper Fidelis."*
 - (2) The color guard marches forward down the line of escorts to the far end of the dance floor, countermarches, marches back down the line of escorts and from the room. (See figure 11-9.)
 - (3) When the colors have cleared the room, the Commanding General and guest of honor march down the line of escorts and from the room. When they have cleared the room, they are followed in a similar manner by the remainder of the General Officers, who march from the room in pairs until the last one has cleared the room. (See figure 11-9.)
- e. The senior escort commands **"Carry, SWORD."** The escorts execute.

(1) The two senior escorts (1st pair) march forward to the centerline of the floor, halt, face the main entrance and march from the ballroom. (See figure 11-10.)

(2) As each successive pair (2nd pair, 3rd pair, etc.) of escorts is uncovered by the preceding escorts, they march forward to the centerline of the dance floor, halt, face the main entrance and march from the ballroom. (See figure 11-10.)

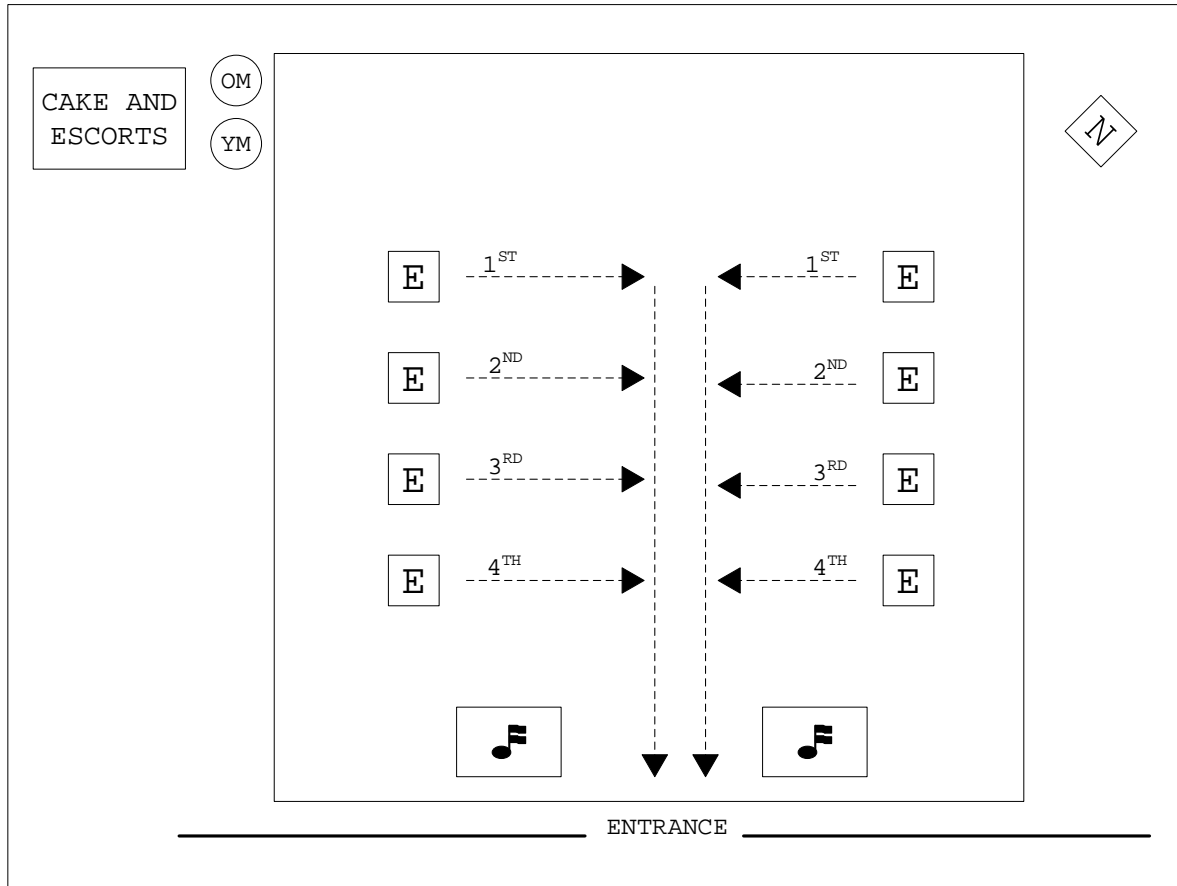

Figure 11-10.--Movements of the Escorts During the March Off.

(3) After the last pair of escorts clear the room, the band plays "Anchors' Aweigh" and "Marines' Hymn."

Note: If the drummers and trumpeters marched out of the ballroom at the beginning of the ceremony then delete the next step.

(4) The drummers and trumpeters close by side-stepping to the right and left, take up the beat, march the length of the dance floor, countermarch, and march back down the floor and out of the entrance way. (See figure 11-11.) As the last trumpeter clears the entranceway, the doors are closed.

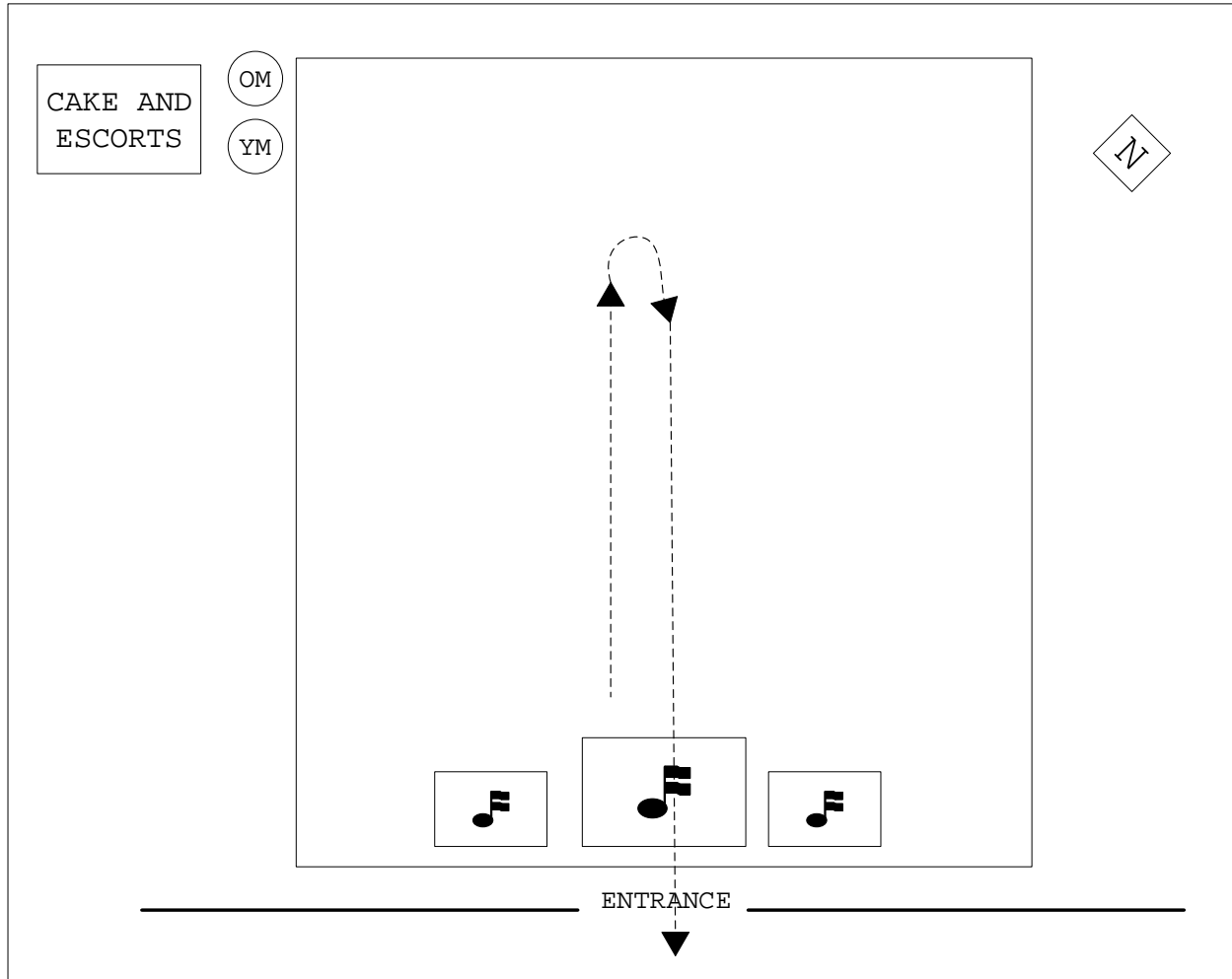

Figure 11-11.--Movements of the Drummers and Trumpeters During the March Off.

Note: The Commanding General (or commanding officer)/guest of honor make remarks before the ceremony is concluded.

NARRATOR: "LADIES AND GENTLEMEN, THE COMMANDING GENERAL (name and title)."
The Commanding General makes a few brief remarks and introduces the guest of honor, who makes appropriate remarks concerning the significance of the birthday, etc., remarks should be brief and to the point.

NARRATOR: "LADIES AND GENTLEMEN, THIS CONCLUDES OUR CEREMONY. PLEASE ENJOY YOUR EVENING, SEMPER FIDELIS, AND HAPPY BIRTHDAY MARINES!"

Note: In the case where no General Officer is in attendance, substitute one of the following for the term "Commanding General."

Unit/Officer's Ball	Commanding Officer
SNCO Ball	The Rank of the senior enlisted present
Enlisted Ball	Ball Committee Chairman

5. Variations. It is recognized that considerable variation must be made

in this ceremony to conform to the configuration of the dance floor or the absence of a band. Examples are:

a. When the ceremony is conducted at posts where there is no General Officer commanding, the senior line officer will follow the procedure outlined above for the Commanding General. At such posts, the escorts will be formed from the appropriate ranks present, and the line of General Officers will be deleted.

b. When the ceremony is conducted at noncommissioned officers or other enlisted messes, appropriate ranking noncommissioned officers will preside and form the escort.

c. Where the ballroom is of sufficient size, two officers or enlisted Marines of each rank will be assigned to the escort.

d. Where practicable, the Blue Dress "A," "B" or Service "A" will be worn by those officers and Marines participating in the ceremony.

e. Officers and noncommissioned officers participating in the ceremony should be armed with swords; however, at no time will Marines in the grade of Private through Lance Corporal be armed with a sword. If the ceremony is conducted in utilities because of field duty, deployment, etc., the sword will not be worn.

f. The birthday cake will be mounted on a mess serving cart or similar conveyance covered with scarlet and gold bunting.

g. Where swords are not available, escorts will execute a hand salute whenever the command of "**Present, ARMS**" is given.

h. Guests may be cleared from the center of the ballroom by stretching white lines, supported by second lieutenants or noncommissioned officers, moving from the center line of the dance floor toward either side to provide required space for the ceremony.

6. Recommended Personnel Assignments

a. The number of officers and Marines assigned to be escorts will depend on the number of personnel available to the command and the space available to conduct the ceremony. The following are some examples of the composition of the escorts.

OFFICERS BALL			
OPTION A		OPTION B	
Col	Col	Col	LtCol
LtCol	LtCol	Maj	Capt
Maj	Maj	1stLt	2ndLt
Capt	Capt	CWO	CWO
1stLt	1stLt		
2ndLt	2ndLt		
CWO5	CWO5		
CWO4	CWO4		
CWO3	CWO3		
CWO2	CWO2		
WO1	WO1		

STAFF NONCOMMISSIONED OFFICERS BALL			
OPTION A		OPTION B	
SgtMaj	SgtMaj	SgtMaj	MGySgt
MGySgt	MGySgt	1stSgt	MSgt
1stSgt	1stSgt	GySgt	SSgt
MSgt	MSgt		
GySgt	GySgt		
SSgt	SSgt		

UNIT/ALL RANKS BALL	
Col	LtCol
Maj	Capt
1stLt	2ndLt
CWO	CWO
SgtMaj	MGySgt
1stSgt	MSgt
GySgt	SSgt
Sgt	Cpl
LCpl*	PFC*
Pvt*	Pvt*

Enlisted Ball	
Sgt	Sgt
Cpl	Cpl
LCpl*	LCpl
PFC*	PFC*

b. The adjutant should be assigned as follows:

BALL	ADJUTANT ASSIGNED
Officers or all ranks	Major or Captain
Staff Noncommissioned Officer	Gunnery Sergeant or Staff Sergeant
Enlisted	Sergeant or Corporal

c. Cake escorts should be assigned as follows:

OFFICERS BALL		SNCO BALL		ENLISTED BALL		UNIT/ALL HANDS BALL	
2ndLt	2ndLt	GySgt	GySgt	PFC*	PFC*	2ndLt	SSgt
WO1	WO1	SSgt	SSgt	Pvt*	Pvt*	WO1	Pvt*

*Marines in the grades of Pvt, PFC, and LCpl are never armed with a sword.

Chapter 12

Mess Night

TABLE OF CONTENTS

<u>IDENTIFICATION</u>	<u>TITLE</u>	<u>PAGE</u>
1.	General.....	12-2
2.	Schedule of Events.....	12-2
3.	Sequence.....	12-3

Chapter 12

Mess Night

1. General

a. It has long been an established custom of the officers and/or noncommissioned officers of a military organization to dine together periodically. A mess night is a formal dinner in mess by all members, or by the officers and noncommissioned officers of a particular post or unit. It is sometimes called a "Guest Night" or a "Dining-in" and less commonly as a "Formal Mess Dinner" or "Band Night." The mess night is a formal stag dinner where spouses and dates do not attend. The object of a mess night may vary from a wish to foster good comradeship among fellow Marines, to celebrate the anniversary of significant events in a unit's history, to "dine-out" members being detached, or to honor guests from another unit, service or country.

b. The procedures for a mess night outlined in this chapter are to be used as a guide. Commanders may modify these procedures to accommodate local requirements and restrictions. In addition to the information contained in this chapter, additional guidance concerning invitations, seating and protocol may be found in enclosure 3, appendix D, in Oretta D. Swartz's, "*Service Etiquette the Marine Officer's Guide*," fourth edition, and, "*Handbook for Marine Noncommissioned Officers*," published by the Naval Institute Press.

2. Schedule of Events. Drawing upon our history and traditions, the following general routine is a standard guideline for Mess Nights, subject to modification as required.

a. Key personnel arrive and supervise last minute preparations.

b. Members of the mess arrive, the bar is opened and the cocktail hour begins. This is normally 45 minutes before dinner.

c. Guest of honor arrives and is met by the escort.

d. Fifteen minutes prior to dinner, "*First Call*" or "*Dinner Chimes*" is sounded. At this time, all present will finish their drinks, make final head calls (since no one will be excused from the dining room during the dinner without permission from the Mess President), and begin assembling for the march on. No drinks or tobacco are to be carried into the dining area.

e. Five minutes prior to dinner, "*Officers Call*" is sounded ("*First Sergeant's Call*" is sounded at an enlisted mess). All members form in the order they are to be seated. The official party, who occupies the head table, is the last unit to form and enter the mess. At this time, the smoking lamp is out.

f. At the appointed time, the drum and trumpet detail plays "*Sea Soldiers*" as the members of the mess march on. Members of the mess march smartly to their assigned seats and remain standing while the entire mess assembles. The official party enters smartly and moves to their assigned position at the head table as "*Semper Fidelis*" is played. When the head table is occupied, the music ceases. All hands remain standing for the

grace.

g. Grace is offered. Either a chaplain, President of the Mess, or Mr./Madam Vice does this.

h. Dinner is served, after the last of the wine and soup is removed, "Parade the Beef."

i. "Shed a Tear." It is optional at the end of the meal to allow a break.

j. Port is served and the smoking lamp lighted. It is customary at this time to open the floor to fining although this may be omitted or done at a different time.

k. Mess President remarks.

l. Introduction of guests and remarks by the guest of honor.

m. Toasting.

n. Secure from the dining room and move to the bar.

o. After dinner activities.

3. Sequence. This sequence of events is a summation of the night activities, a "refresher" outline for what takes place at a mess night. Times are given for the events prior to and after the meal. Events during the meal are not regulated by time. The following is an example of a mess night sequence.

a. The President and Mr./Madam Vice have verified that all arrangements have been made and are standing by to begin the cocktail hour.

b. Members of the mess begin arriving prior to the guests. Cash bar provided. Members are reminded to consult the seating chart.

c. H Hour-60 Minutes. Cocktail hour begins and guests begin arriving. Guest of honor arrives. All are met by Mr./Madam Vice and introduced to the mess president and members of the mess.

d. H Hour-15 Minutes. "First Call" or "Dinner Chimes" is sounded. All present finish drinks, make final head calls, and begin assembling for the march on.

e. H Hour-5 Minutes. Assemble. "Officer's Call" or "First Sergeant's Call" is sounded. All members assemble [to include any guests] in the order they are to be seated and stand by for the march on. The head table forms last and enters separately.

f. H-Hour. March on. Mr./Madam Vice commands "**Forward, MARCH.**" As the members step off, "Sea Soldiers" is played. Members and guests march to their place and stand behind their chairs. Once all are in place and the music stops, Mr./Madam President commands "**Forward, MARCH**" for the head table. As the head table steps off, "Semper Fidelis" plays. Once the head table is in place, the music stops and all remain standing.

g. Mr./Madam Vice: **"Mr./Madam President, all members of the mess and guests are present."**

h. Mr./Madam President: **"Chaplain, offer the grace."** (Note if a chaplain is not present then either Mr./Madam President or Mr./Madam Vice may offer grace.)

i. Mr./Madam President: **Raps the gavel once** and states **"Please be seated."** The members will wait until the head table is seated and then sit. Appetizer is served (e.g., shrimp cocktail, salad), and after the last of the soup bowls and glasses are removed, the next course will start. Members will not begin eating each course until after the President and guest start.

j. The President stands, **raps the gavel three times** and states **"Mr./Madam Vice, bring forth the beef."**

k. Mr./Madam Vice: **"Chief Steward, the beef."** At this time, the music "*Roast Beef of Old England*" is played. Mr./Madam Vice accompanies the chief steward to the head table, is handed a small portion of beef and passes it to the President who tastes it.

l. Mr./Madam President: **"I find this beef tasty and declare it fit for human consumption. Please serve the members of the mess."** The beef is removed to the galley for serving. The music "*Roast Beef of Old England*" is played as the beef is removed. The dinner continues until after dessert is finished.

Note: If the mess night is to include fining, the floor may be opened to fining once the main course is served, or as an option once the smoking lamp is lighted. The President will close the floor for fining whenever the Marine deems fit.

m. After dessert is finished and while the servers are clearing the table, it is optional to allow the members of the mess a short break and make head calls.

n. Mr./Madam Vice: After dinner, stands and requests **"Mr./Madam President, I suggest we shed a tear for Lord Admiral Nelson."**

o. Mr./Madam President: **Raps the gavel twice** (mess stands). **"The mess will adjourn for a 15-minute break."** The official party departs followed by all others. Do not return until called.

p. During the break, Mr./Madam Vice will ensure that coffee, cigars, ashtrays, matches, and wine for toasting is placed on the tables.

q. After 15 minutes and on cue from Mr./Madam Vice, the music "*First Call*" is played. All members and guests return and stand behind their seats. Once all members and guests have returned to their chairs, the head table will march in.

r. Mr./Madam Vice: **"Mr./Madam President, all members and guests of the mess are present."** or **"Mr./Madam President, all members and guests of the mess are not present. Name the offenders."**

s. Mr./Madam President: **Raps gavel once. "Please be seated." Raps gavel three times. "Mr./Madam Vice, the smoking lamp."** After Mr./Madam

Vice has brought forth the smoking lamp and lighted the cigars of Mr./Madam President, the President announces **"Ladies and Gentlemen, the smoking lamp is lighted."**

t. Mr./Madam President: **Raps gavel three times.** "Mr./Madam Vice bring forth the wine for toasting."

u. Mr./Madam Vice: **"Chief Steward, the wine."** Mr./Madam Vice accompanies the chief steward and pores the wine for the guest of honor and Mr./Madam President. When all glasses are charged, Mr./Madam Vice stands and announces **"Mr./Madam President, all glasses are charged,"** and remains standing.

v. Mr./Madam President: Stands and **raps gavel three times.** Takes wine glass in right hand and announces **"Mr./Madam Vice, a toast to the Commander and Chief, the President of the United States."** If foreign guests are present, then the first toast is given to the head of state of that guest and any others in order of seniority. The senior foreign guest would then toast the President of the United States. Appropriate music is played for all foreign heads of state and the "National Anthem" played after toasting the President of the United States.

w. Mr./Madam President: Stands and **raps gavel three times**, moves to podium. At this point, Mr./Madam President makes opening remarks followed by the introduction of the guests of the mess. Once the guests are introduced, Mr./Madam President introduces the guest of honor.

(1) **"Ladies and Gentlemen, it is my personal pleasure and professional privilege to introduce our guest of honor, _____."**

(2) Remarks by guest of honor.

(3) Presentation of memento to guest of honor.

x. Mr./Madam President: Stands and **raps gavel three times.** **"The floor is now open for toasting."** At this time, official, traditional and personal toasts are made per enclosure 3, appendix D, paragraph 7 and local custom. At most mess nights, the toasts are prearranged to include the loyalty toast, the traditional toast, and the toast to our fallen comrades and a toast to Country and Corps. The toasts are given in the following manner; each Marine selected for a particular toast will stand with glass in right hand, faces Mr./Madam Vice, and states:

(1) **"Mr./Madam Vice, (Mr./Madam Vice stands), A toast to the Continental Marines who fought for freedom and liberty."** Mr./Madam Vice will state, **"Ladies and Gentlemen, a toast** (all members stand with wine glasses in right hand), **to the Continental Marines."** All members raise their glasses, repeat in unison the words of Mr./Madam Vice, **"To the Continental Marines"** drink a portion of their wine, and resume their seats. This sequence is followed for each toast.

(2) **"Mr./Madam Vice, A toast to the Marines of the 19th century who fought from the halls of Montezuma to the shores of Tripoli."** Mr./Madam Vice: **"Ladies and Gentlemen, A toast to the Marines of the 19th century."**
Mess: **"To the Marines of the 19th century."**

(3) **"Mr./Madam Vice, A toast to the Marines of World War I who**

fought from the Argonne Forest to Belleau Wood." Mr./Madam Vice: "Ladies and Gentlemen, A toast to the Marines of World War I." Mess: "To the Marines of World War I."

(4) "Mr./Madam Vice, A toast to the Marines who fought in the Island campaigns of World War II, where uncommon valor was a common virtue." Mr./Madam Vice: "Ladies and Gentlemen, A toast to the Marines of World War II." Mess: "To the Marines of World War II."

(5) "Mr./Madam Vice, A toast to the Marines who fought in Korea from Inchon to the Chosin Reservoir." Mr./Madam Vice: "Ladies and Gentlemen, A toast to the Marines who fought in Korea." Mess: "To the Marines who fought in Korea."

(6) "Mr./Madam Vice, A toast to the Marines who fought for freedom in Vietnam." Mr./Madam Vice: "Ladies and Gentlemen, A toast to the Marines who fought in Vietnam." Mess: "To the Marines who fought in Vietnam."

(7) "Mr./Madam Vice, A toast to the Marines who fought oppression in Lebanon and Grenada." Mr./Madam Vice: "Ladies and Gentlemen, A toast to the Marines who fought oppression in Lebanon and Grenada." Mess: "To the Marines of Lebanon and Grenada."

(8) "Mr./Madam Vice, A toast to the Marines who fought for Kuwait liberty in Southwest Asia." Mr./Madam Vice: "Ladies and Gentlemen, A toast to the Marines of Desert Shield and Desert Storm." Mess: "To the Marines of Desert Shield and Desert Storm."

(9) "Mr./Madam Vice, A toast to the Marines who fought in Operation Enduring Freedom." Mr./Madam Vice: "Ladies and Gentlemen, A toast to the Marines of Operation Enduring Freedom." Mess: "To the Marines of Operation Enduring Freedom."

(10) "Mr./Madam Vice, A toast to the Marines who fought in Operation Iraqi Freedom." Mr./Madam Vice: "Ladies and Gentlemen, A toast to the Marines of Operation Iraqi Freedom." Mess: "To the Marines of Operation Iraqi Freedom."

(11) "Mr./Madam Vice, A toast to our comrades in arms, the United States Navy Corpsmen." Mr./Madam Vice: "Ladies and Gentlemen, A toast to our comrades in arms, the United States Navy Corpsmen." Mess: "To Navy Corpsmen."

Note: This toast may be omitted if the toast to the United States Navy is done during the official toasts.

(12) "Mr./Madam Vice, A toast to the Marines currently deployed on the forward edge of our Nation's defense." Mr./Madam Vice: "Ladies and Gentlemen, A toast to Marines currently deployed." Mess: "To Marines currently deployed."

(13) In place of the above toasts, the procedures outlined in enclosure 3, appendix D, paragraph 7; paragraph 7.g.(8) can be used. During the above sequence, the appropriate toasts to other services will be inserted as directed by the President of the Mess.

(14) Mr./Madam Vice: "I too have a toast; as you entered this banquet hall, you should have noticed that before us tonight stands an empty chair and a single lone table draped in black, signifying all of our fallen comrades who are not with us this evening, because they have given the full measure of devotion to our Country and to our beloved Corps. The single lighted candle reminds us of the flame of eternal life. That the memory of our fallen comrades will be with us always. The Purple Heart Medal displayed to reflect the shedding of blood and the ebb of life in battle. The identification tags, blank, yet they could bear the name of any of us here tonight. The dinner setting, inverted, they break bread with us in spirit only. Ladies and Gentlemen, a toast, To our fallen comrades." Mess: "To our fallen comrades." "TAPS" is played.

y. At this time, the President can make appropriate remarks concerning business of the mess to include hail and farewell of members, recent promotions, etc.

z. Mr./Madam President: "Mr./Madam Vice, bring forth the rum punch." Mr./Madam Vice uses the same procedures as for wine and remains standing throughout.

aa. Mr./Madam Vice: After all glasses are charged states "Mr./Madam President, all glasses are charged."

ab. Mr./Madam President: "In 1776, one of the first recruiting posters ordered recruits upon enlistment, take courage then, seize the fortune that awaits you, repair to the Marine rendezvous, where in a flowing bowl of punch, and three times three you shall drink (pause), long live the United States and success to the Marines. Mr./Madam Vice, a toast to the country and Corps."

ac. Mr./Madam Vice: "Ladies and Gentlemen, a toast, long live the United States and success to the Marines." Mess: All repeat, glasses are emptied and inverted. "Marine's Hymn" is played. It is more appropriate at this time to have the mess sing all three versus of the Marine's Hymn.

ad. Mr./Madam Vice: Ensures those who prepared and served the meal are present and standing behind Mr./Madam Vice's table.

ae. Mr./Madam President: *Raps gavel three times.* "Ladies and Gentlemen, join me in a round of applause for the staff who have prepared and served the meal and drinks in honor of our mess this evening and which we have enjoyed." (Leads applause.)

af. Mr./Madam President: *Raps gavel three times.* "Ladies and Gentlemen, join me at the bar." Members remain standing until the head table has departed.

Chapter 13

Funerals and Memorial Services

TABLE OF CONTENTS

<u>IDENTIFICATION</u>	<u>TITLE</u>	<u>PAGE</u>
1.	General.....	13-2
2.	Duties of the Officer in Charge of the Ceremony...	13-4
3.	Receiving the Remains.....	13-6
4.	Procession.....	13-10
5.	At the Grave.....	13-13
6.	Memorial Service Honors.....	13-20
7.	Conduct of Funerals When Military Personnel are Limited.....	13-21
8.	Unit Outdoor Memorial Services When Remains are Interned at Deceased Home of Record.....	13-21
9.	Unit Indoor Memorial Services When Remains are Interned at Deceased Home of Record.....	13-23
Figure 13-1	Receiving the Remains from a Building.....	13-6
Figure 13-2a	Pallbearers Entering; Leaving the Chapel.....	13-7
Figure 13-2b	Entering Chapel; Leaving Chapel.....	13-8
Figure 13-3	Receiving Remains at Cemetery Gates (Transferring Remains from Hearse or Caisson).....	13-9
Figure 13-4	Order of March of Funeral Procession.....	13-12
Figure 13-5	Receiving the Remains at the Burial Ground.....	13-15
Figure 13-6	March to the Grave.....	13-16
Figure 13-7	A Distribution of Units at the Grave.....	13-18
Figure 13-8	Honor Guard.....	13-20
Figure 13-9	Company Memorial Formation.....	13-23

Chapter 13

Funerals and Memorial Services

1. General

a. When not contrary to orders and regulations, the extent to which the Naval service participates in a funeral depends upon the expressed wishes of the family of the deceased.

b. The composition and strength of the escort will be as prescribed in reference (i) or as modified by proper authority.

c. The military aspect of a funeral usually begins at one of the following places, home of the deceased, mortuary, railroad station, church or chapel, cemetery gates, or the grave. It may, however, begin at any designated place.

d. The ceremony starts when the escort first receives the remains. Before that, the body bearers may be detailed to conduct the remains wherever necessary.

e. In general, the escort receives the body at one of the following places:

(1) The designated place and conducts it to the place of services and then to the grave.

(2) The chapel before, and conducts it to the grave after the services.

(3) The cemetery gates and conducts it to the grave.

(4) The grave.

f. Each time the body bearers remove the remains:

(1) The escort is brought to present arms.

(2) The band renders prescribed honors, followed by appropriate music.

(3) The pallbearers salute.

(4) All observers in uniform, except the body bearers, salute.

(5) All civilian-dressed Naval personnel, except women, uncover and hold the headdress over the heart with the right hand. Women place the right hand over the heart without uncovering.

g. When the national colors is draped on the casket, it shall be placed so the stars are at the head of the casket over the left shoulder of the deceased. Nothing shall rest on top of the national colors. The colors will be removed as the casket is being lowered into the grave, and in time so the colors will not touch the ground.

h. The casket is always carried foot first, except in the case of a clergyman whose casket is carried into and out of the church or chapel head first.

i. Pallbearers may walk or ride, depending upon the distance to be covered.

j. The senior pallbearer will give necessary cautionary commands to the others in a low voice. All salute at the command "**Present, ARMS**" when given by the escort commander.

k. The personal flag of a deceased general or flag officer will be carried immediately in front of the hearse or caisson. If he was a unit commander or ship's captain, the command or commission pennant will also be carried.

l. If the entrance to the cemetery prevents the hearse or caisson from entering, the procession halts, the casket is removed, and the procession proceeds again.

m. When the deceased is entitled, the minute gun salute prescribed by reference (i) is fired. The first gun fires as the body enters the cemetery. Three volleys are fired at five-second intervals as the casket is lowered into the grave.

n. When the band is playing a hymn and it becomes necessary to stop, it continues until the next stanza ends.

o. Uniformed officers in an official capacity will wear a mourning band on the left sleeve. If armed with the sword, its hilt will be affixed with the mourning knot.

Note: No weapons to include swords will be worn or brought into the chapel.

p. Participation by fraternal or patriotic organizations is as follows:

(1) Fraternal or semi-military organizations of which the deceased was a member may participate in the service if desired by the immediate family.

(2) If the ritual is military or semi-military, the rites will begin immediately after the military ceremony. If it includes the firing of three volleys and "*Taps*," these features of the military ceremony may be postponed until their appropriate places in the ritual, at which times the military firing party and bugler may render the honors.

q. When the body has been cremated, casket, body, and remains, as used herein, refer to the container of the ashes.

(1) For all phases of the funeral in which the cremated remains are carried by hand, one enlisted man will be detailed to carry the receptacle. Four enlisted men will be detailed as flag bearers. When the receptacle is carried from a conveyance into the chapel, from the chapel to the conveyance, or from the conveyance to the grave, the flag bearers will follow the receptacle with the flag folded as prescribed in enclosure 1, chapter 7, paragraph 3.f. and carried by the leading flag bearer on the right.

(2) When the receptacle has been placed on the stand before the chancel of the chapel, or when placed in the conveyance, the flag will be folded and placed inside it. If the caisson is equipped with a casket container for the receptacle, the open flag will be laid on the container as

prescribed for a casket.

(3) When a hearse or caisson is not used, suitable transportation will be provided the receptacle bearer and flag bearers.

(4) When the remains are to be conducted to a crematory and the ashes interred with military honors at a later time, the ceremony will consist only of the escort to the crematory. Arms will be presented as the body is carried into the crematory. Volley firing and "Taps" are omitted. If the funeral is held at the crematory and no further military honors are anticipated, the volleys will be fired (if local ordinances permit) and "Taps" sounded outside the crematory.

2. Duties of the Officer in Charge of the Ceremony

a. The officer in charge should be detailed in sufficient time before the funeral to allow planning and prior arrangements. The officer in charge will confer with the clergy and funeral director. Together they will ensure that all necessary arrangements have been made. The chaplain will perform the duties of officer in charge of the ceremony in case no other officer is so designated.

b. As soon as the service in the church or chapel has begun, the officer in charge will:

(1) Make sure the hearse or caisson is ready to receive the casket at the front entrance.

(2) Ensure a conveyance for flowers is posted at the side or rear-entrance.

(3) Arrange the cars for the clergy, pallbearers, and immediate family (if the procession is to ride) in the proper order. (See figure 13-1.)

(4) Designate four of the body bearers to help carry the flowers out after the body has been placed in the conveyance. They should return through the side or rear door, at whichever the flower conveyance is parked. The remaining body bearers will secure the casket on the caisson or hearse. After the flowers have been moved, the four designated body bearers will take position in rear of the caisson or hearse.

c. When the body is transferred from the hearse to the caisson, the officer in charge will be in the vicinity. He will signal the escort commander when the transfer begins and when it is completed.

d. When the procession is in motion, the officer in charge will go to the grave and await the arrival of the funeral party. He will determine the positions for the band, escort, firing party (if separated from the escort), the bugler, and other units. Upon their arrival, he will direct these individuals and units to their proper positions at the grave.

e. After the units and individuals are in position at the grave, he will signal the body bearers to carry the remains from the conveyance and the band and escort to render the honors.

f. When the widow or mother of the deceased is unaccompanied, the officer in charge will escort her from the car to the grave. When practicable, he will remain with her to render assistance until completion of the commitment.

g. After the commitment service, he will deliver the folded national colors, used on the casket, to the family of the deceased.

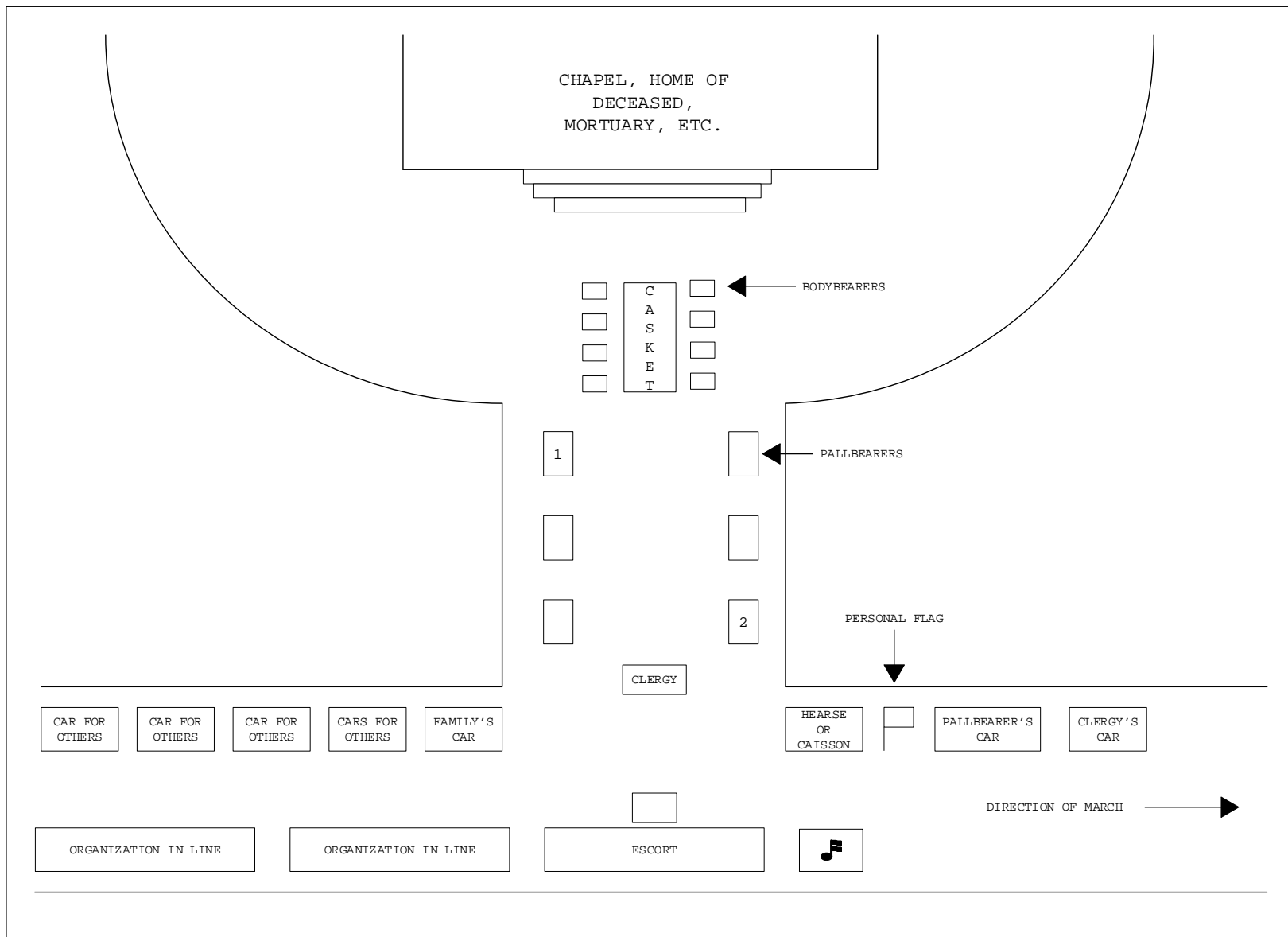

Figure 13-1.--Receiving the Remains from a Building.

h. When situations arise which are not covered in this Manual, the officer in charge will use his/her own judgment.

i. Final decisions pertaining to troop handling or movement will be made by the officer in charge. All orders to troops participating in a funeral party will be given through the officer in charge.

j. The officer in charge must cooperate with the funeral director engaged by the deceased's family. The officer in charge must not arbitrarily assume the duties the funeral director is being paid to perform.

k. The officer in charge will explain the nature and significance of the volleys to the next of kin, or those representing the next of kin, and ascertain whether the volleys are desired.

3. Receiving the Remains

a. Whenever the remains are received, the following procedure will govern. (See figures 13-1, 13-2, and 13-3.)



Figure 13-2a.--Pallbearers Entering; Leaving the Chapel.

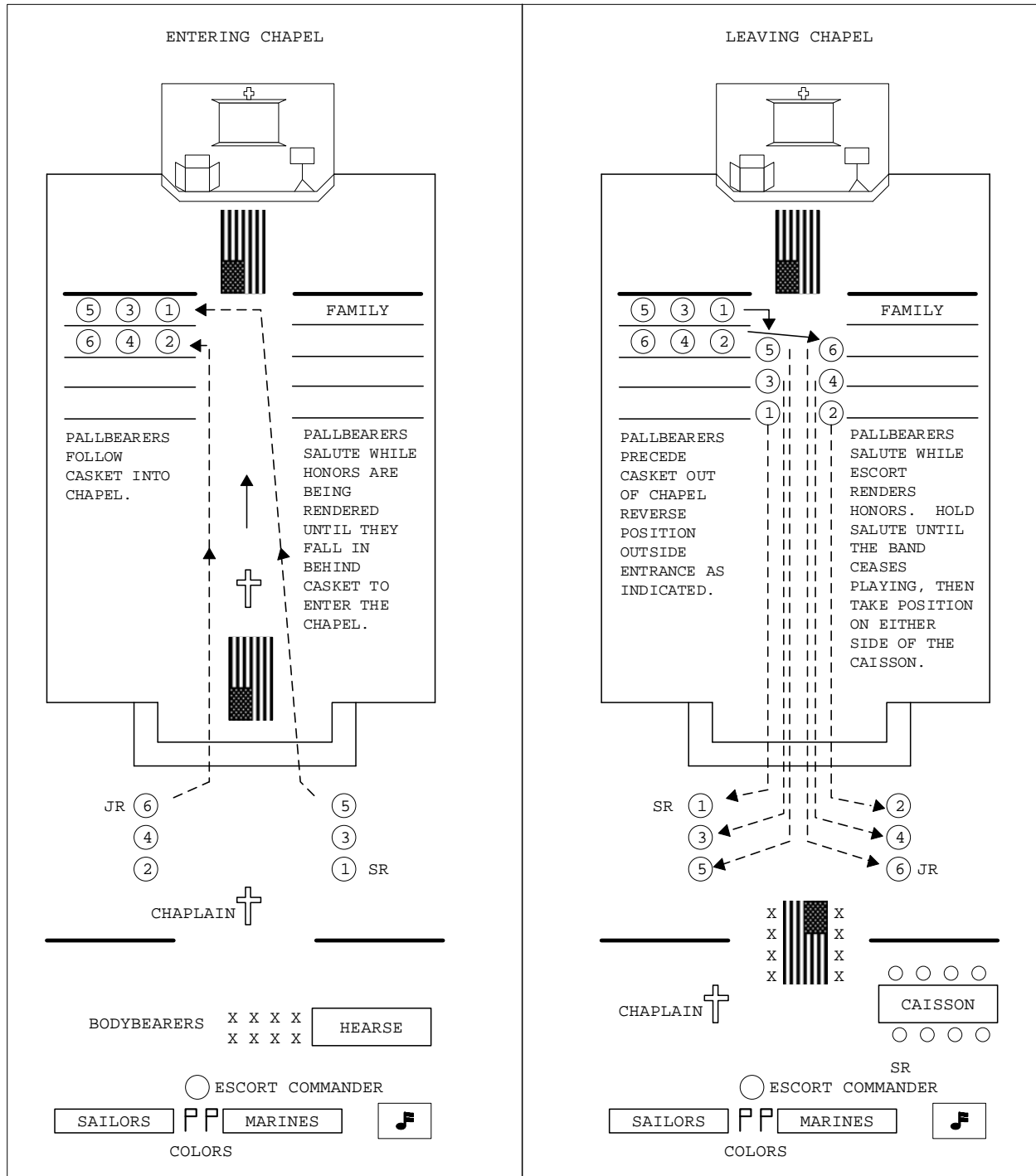

Figure 13-2b.--Entering Chapel; Leaving Chapel.

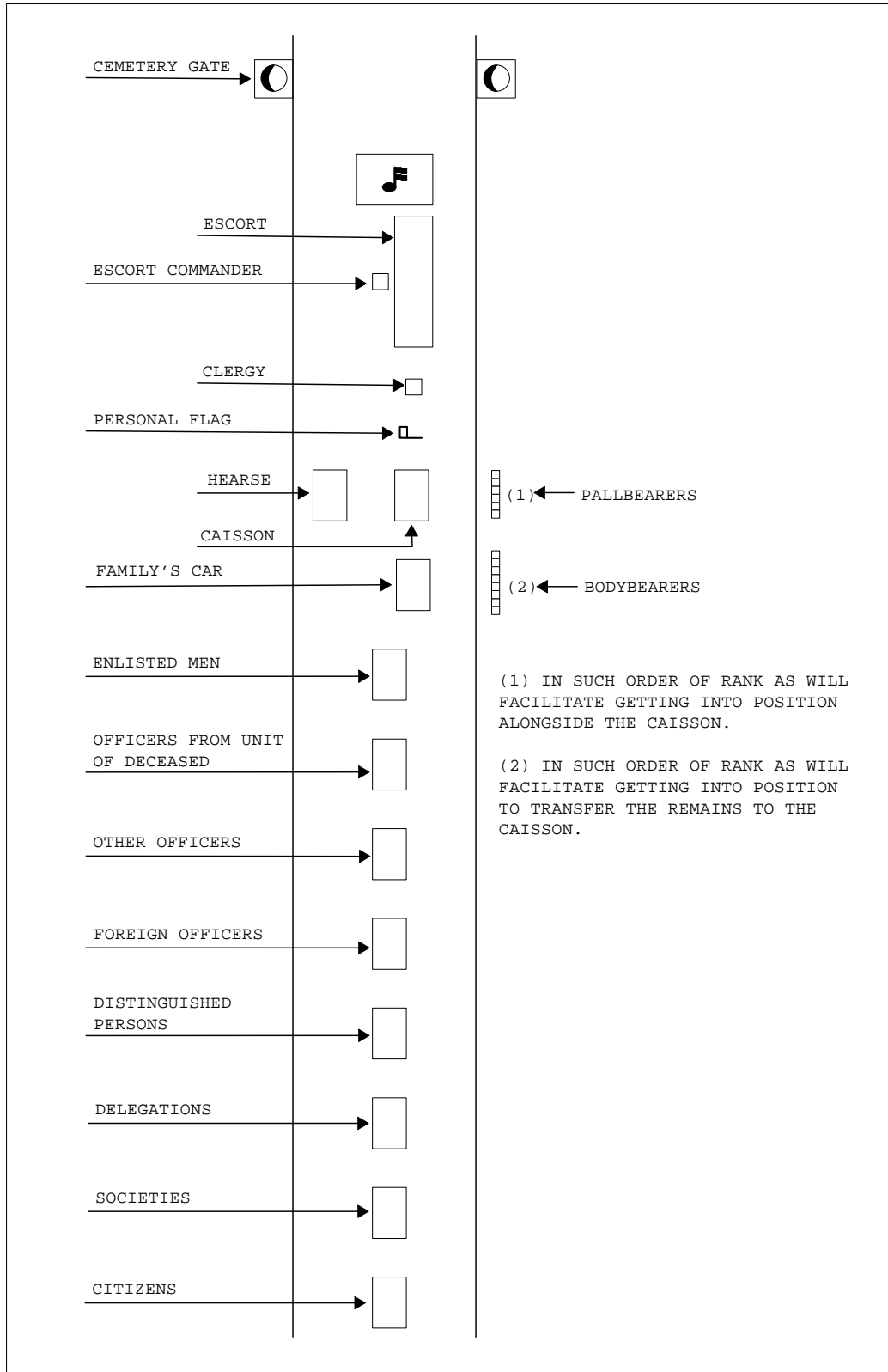

Figure 13-3.--Receiving Remains at Cemetery Gates (Transferring Remains from Hearse or Caisson).

b. The escort is formed opposite the place where the remains are to be received. As they arrive, or when all is ready to receive the remains, the commander of the escort commands "**Present, ARMS.**" After the remains have been received, the door to the hearse is closed, or the casket secured to the caisson, and the escort commander orders "**Order, ARMS.**"

c. The band is formed on the flank toward which the escort is to march. At the command of execution for present arms by the escort commander, the band will render musical honors if the deceased is entitled to such honors. Following this, they play appropriate music; stopping at the next stanza ending after order arms has been ordered.

d. The bearer of the personal flag of the deceased takes position and marches in front of the hearse or caisson.

e. Duties of the pallbearers are as follows:

(1) When the remains are received at the chapel before the service, form in two ranks facing inboard at the entrance with the juniors nearest the door. They must allow room between ranks for the casket to pass between them. As the casket is removed from the hearse or caisson, they execute the first movement of the hand salute. The second movement is executed as the casket passes, after which they face toward the door and follow the casket into the chapel. Seats are usually reserved for them among the left front pews.

(2) When the remains are received from a building (see figure 13-1), assemble inside the building in column of twos, in reverse order of rank, junior to the left front, prepared to march out. They follow the clergy from the building (preceding the casket), open to allow the casket to pass between, halt, face inboard, and salute while the casket is passing. They remain at hand salute until the escort executes order arms. They then take their place in two columns of files on each side of the casket in inverse order of rank, junior to the left front, the leading person of each column opposite the front wheels of the hearse or caisson.

(3) When the remains are received at the cemetery gates (see figure 13-3), they form in a single rank on the flank of the escort, opposite the hearse or caisson and in such order of rank that moving to position alongside the caisson is facilitated. They execute and terminate the hand salute on the commands for present and order arms by the escort commander. After present arms, they take their places beside the hearse or caisson as described in paragraph 3.e.(2) of this chapter.

f. The body bearers, if not already with the remains, form on the left of the pallbearers. They leave the formation at the proper time to receive the casket and carry it to the chapel, caisson, or grave. They form, according to height, on each side of the casket. While indoors and not carrying the casket, they uncover. Outdoors they remain covered.

4. Procession

a. After the remains have been placed in the hearse or caisson and all is ready, the officer in charge of the ceremony signals the escort commander. The escort commander puts the band and escort in motion. Elements in rear follow.

b. The procession forms in the following order: (See figure 13-4.)

- (1) Escort commander.
- (2) Band or bugler.
- (3) Escort in suitable formation.
- (4) Clergy.
- (5) Pallbearers if riding.
- (6) Personal flag if rated.

(7) Casket. If pallbearers are not riding, they form on either side of the hearse or caisson as described in paragraph 3.e.(2) in this chapter. If the pallbearers ride, the body bearers take the place of the pallbearers.

- (8) Body bearers in column of twos behind the hearse or caisson.
- (9) Family of the deceased.
- (10) Enlisted men.
- (11) Officers from the ship or organization of the deceased, in inverse order of rank.
- (12) Other officers in inverse order of rank.
- (13) Foreign officers.
- (14) Distinguished persons.
- (15) Delegations.
- (16) Societies.
- (17) Citizens.

c. The procession marches in slow time to solemn music.

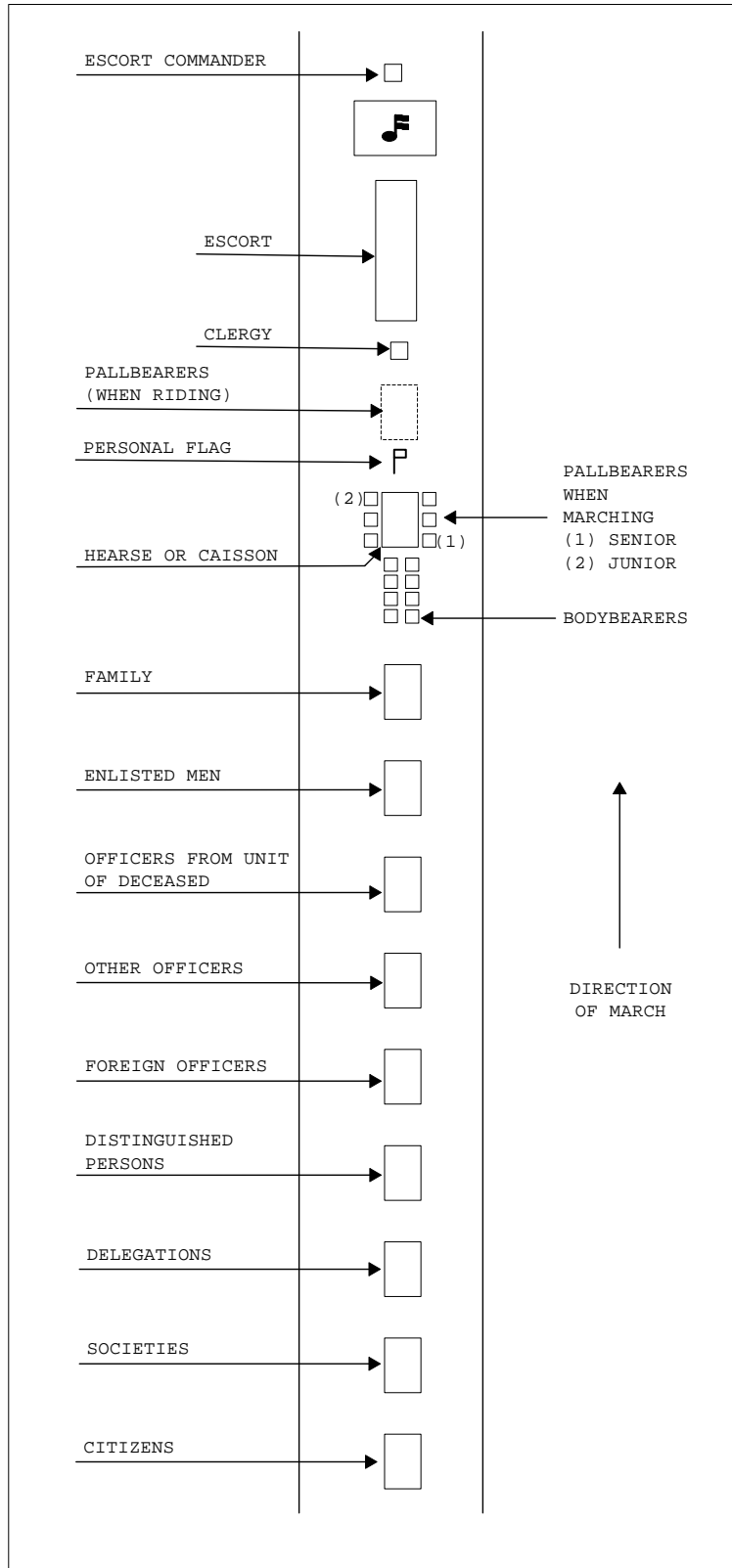

Figure 13-4.--Order of March of Funeral Procession.

5. At the Grave

a. As the procession arrives at the grave, units turn out of column and take the following positions: (See figure 13-5.)

(1) The band forms in line with and on the right of the escort.

(2) The escort forms in line facing the grave at a position indicated by the officer in charge of the ceremony. It should be at least 50 feet from the grave so the volleys will not disturb the mourners. The terrain may dictate that the formation be inverted with the band on the left.

(3) The clergy forms between the hearse or caisson and the grave.

(4) The bearer of the personal flag of the deceased takes post between the clergy and the caisson or hearse.

(5) The pallbearers form in two ranks between the clergy and the grave. They face each other with the juniors nearest the grave. They allow room between their ranks to permit passage of the casket.

(6) The family of the deceased remains near the caisson or hearse.

(7) Other units form in separate lines near and facing the grave. Their positions are indicated by the officer in charge of the ceremony.

b. When all units are in position and upon signal of the officer in charge of the ceremony, the body bearers remove the casket from the caisson or hearse. They carry it between the pallbearers and in front of the escort, then place it on the lowering device over the grave. They raise the national colors by the corners and sides and hold it waist or shoulder high until the end of the service.

c. As the body bearers remove the casket from the caisson or hearse: (See figure 13-6.)

(1) The escort commander commands "**Present, ARMS.**" The band renders prescribed honors, if rated, after which they play appropriate music. The music stops when the casket is placed on the lowering device.

(2) The escort presents arms until the casket is placed on the lowering device.

(3) The clergy precedes the personal flag and the casket to the grave.

(4) The flag bearer follows the clergy, preceding the casket, and takes position at the head of the grave. The flag bearer remains there during the service.

(5) The pallbearers salute as the casket passes between them. When the casket has passed, they terminate the salute, face the grave, close interval, and follow the casket. Upon arrival at the grave, they form in two ranks facing the grave, usually just in rear and to one side of the clergy.

(6) The family of the deceased follows the pallbearers and takes position provided for them.

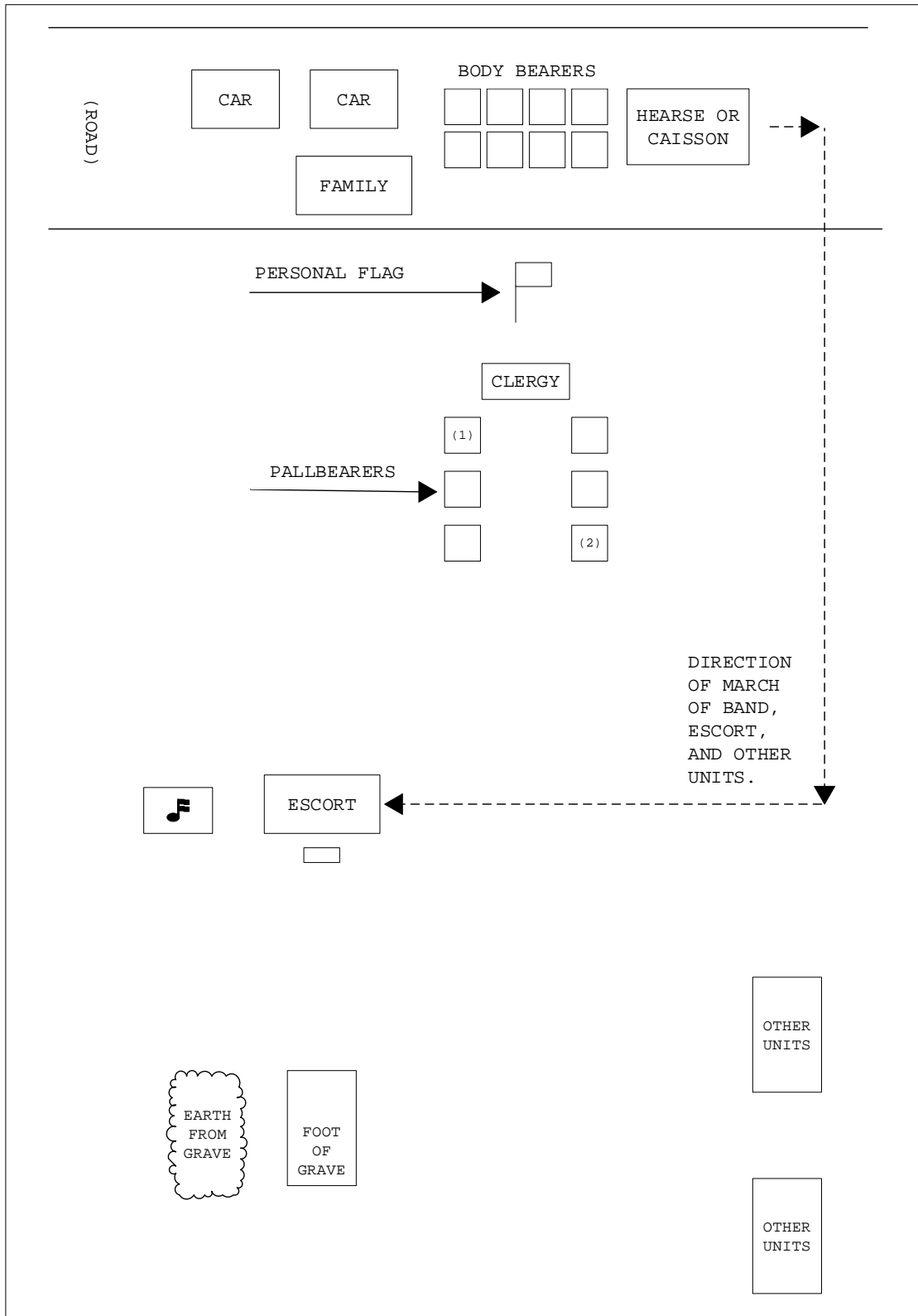

Figure 13-5.--Receiving the Remains at the Burial Ground.

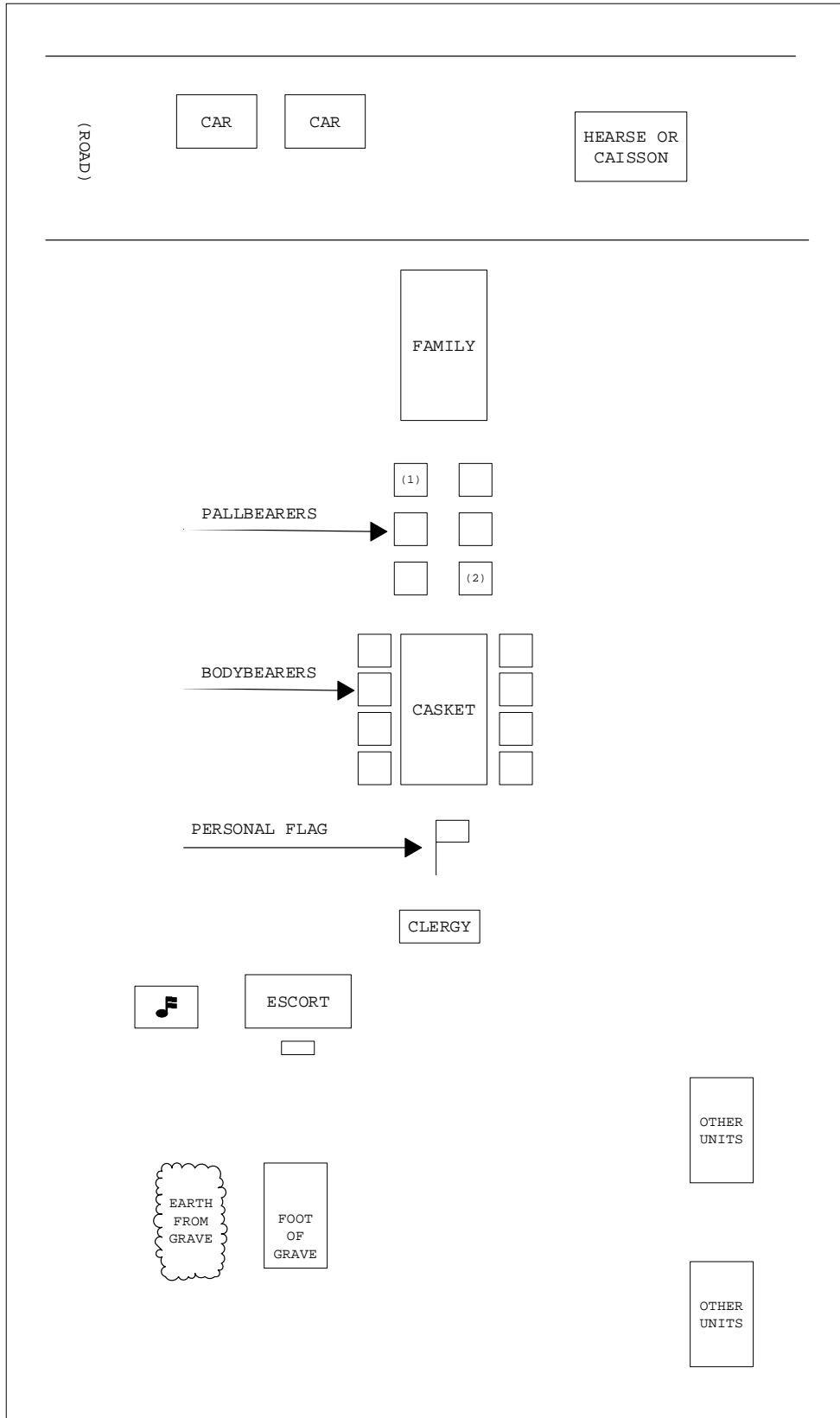

Figure 13-6.--March to the Grave.

d. When the casket is placed on the lowering device and the family has arrived, the following occurs: (See figure 13-7.)

(1) The escort commander orders **"Order, ARMS"** and **"Parade, REST."** Members of the escort execute parade rest.

(2) Pallbearers and other units execute parade rest on the escort commander's order.

(3) The body bearers remain in their positions, holding the national colors so it will not touch the ground when the casket is lowered.

(4) The clergy conducts the commitment service.

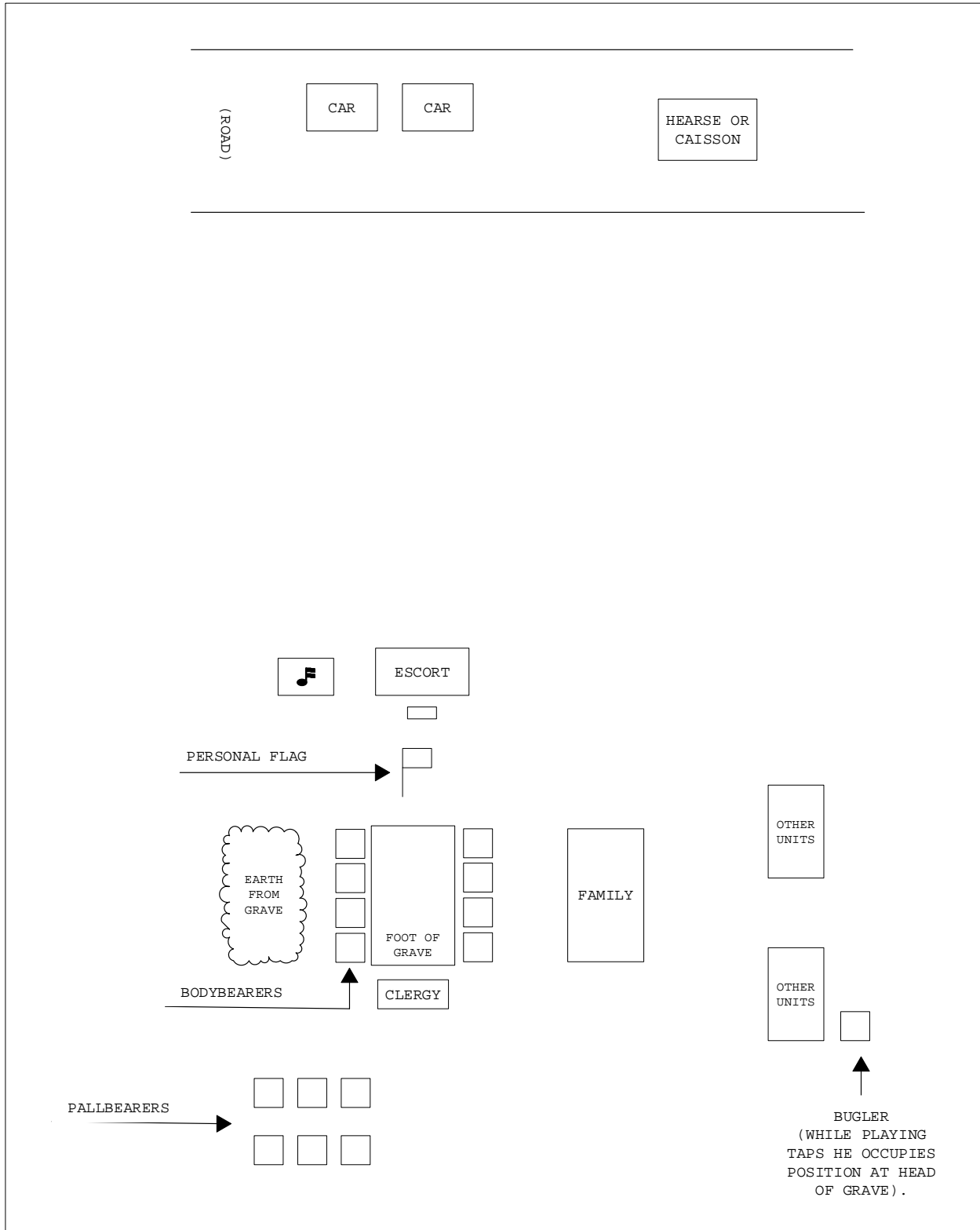

Figure 13-7.--A Distribution of Units at the Grave.

e. After the commitment service:

(1) The escort commander orders "**Escort, ATTENTION,**" the escort commander then commands "**Escort, Present, ARMS.**" The noncommissioned officer in charge of the firing party then gives the command (see enclosure 2, chapter 14) for the firing of volleys. The firing party executes present arms after completion of the three volleys. When sufficient troops are not available for a separate firing party, the front squad of the escort will be designated as the firing party.

(2) The pallbearers come to attention on the command of the escort commander and salute on the Marine's command for present arms.

(3) Other units are brought to attention and present arms at the same time as the escorts.

(4) The clergy come to attention, and if in uniform, salute.

(5) The bandleader comes to attention and salutes.

(6) The bearer of the personal flag of the deceased comes to attention and salutes. If necessary, the Marine first steps aside to allow the bugler to take position for sounding "*Taps.*"

(7) The bugler takes position at the head of the grave on the escort commander's order to present arms. (The officer in charge may direct that the bugler assume a position forward of and to the flank of the escort rather than directly at the head of the grave). The Marine salutes, and then sounds "*Taps*" immediately after the last volley and the firing party executes present arms. The bugler salutes again, faces about, and rejoins his/her unit.

f. After the last note of "*Taps*" has sounded:

(1) The escort commander brings the entire escort to order arms, and after the colors has been folded by the body bearers and presented to the next of kin by the officer in charge, marches the escort and band to a suitable place for dismissal. The band does not play during the march from the grave. The firing party's weapons are unloaded and inspected. If the escort and band continue in formation after cemetery, they remove all mourning and muffling from any colors that may be present. The band then plays march music. Mourning and muffling includes the removal of mourning streamers and bunting from all colors, removal of mourning bands and mourning knots from personnel and swords, and the removal of muffling devices from band instruments.

(2) The pallbearers fall out and withdraw.

(3) The flag bearer folds the flag and rejoins his/her unit.

(4) The body bearers fold the national colors and give it to the officer in charge of the ceremony and march away.

(5) Other units march from the vicinity behind the escort.

6. Memorial Service Honors

a. Upon the request of the next of kin, memorial services will be held for Naval personnel whose remains have been declared non-recoverable.

b. An honor guard is assigned and shall consist of the personnel listed in figure 13-8.

MEMBERS	FULL HONORS (OFFICERS ONLY)	HONORS (ENLISTED, OFFICERS IF SO REQUESTED)
SQUAD LEADER	1	
SQUAD	12	
COLOR GUARD	4	4
BUGLER	1	1
OFFICER IN CHARGE (REPRESENTATIVE OF THE NAVAL DISTRICT COMMANDANT OR DISTRICT MARINE OFFICER)	1	1
CHAPLAIN (IF REQUESTED)	1	1
COLOR BEARER	<u>1</u>	<u>1</u>
TOTAL	21	8

Figure 13-8.--Honor Guard.

c. The ceremony is conducted as follows:

(1) The color bearer is present in the rear of the church or chapel before the arrival of the next of kin. At the exact time set for the service to begin (if next of kin has arrived), the color bearer carries the folded national colors down the center aisle to the altar. The Marine places it on the rostrum, where it remains throughout the ceremony, and retires to the wall on the left of the congregation. For the remainder of the service, the Marine stands at attention, facing inward, just in front of the first pew.

(2) The honor guard, with color guard on their left, forms outside the church or chapel exit that will be used by the next of kin as the individual leaves. They remain at ease outside the church or chapel during the service. When "Taps" is sounded, they come to attention.

(3) The bugler takes position in the vestibule or other room, separate from the congregation.

(4) If requested by the next of kin, the chaplain conducts the service. Otherwise, the family minister or priest presides.

(5) At the conclusion of the service, the bugler sounds "Taps." The chaplain presents the national colors to the next of kin. If a family minister has officiated or the rank of the deceased requires, this duty is performed by the officer in charge.

(6) While presenting the flag, or after the flag has been presented by the chaplain, the officer in charge pays respects and offers the condolences of the District Marine Officer. The chaplain speaks to the next of kin if he/she did not present the flag.

(7) The officer in charge escorts the next of kin from the church or chapel.

(8) The honor guard and color guard are called to attention by the squad leader (senior color bearer if squad is not present) upon the appearance of the next of kin. As the next of kin approaches to within six paces, the squad leader orders "**Present, ARMS.**" The position of present arms is retained until the squad leader is directed to give order arms by the officer in charge. This will be after the next of kin has departed the vicinity.

(9) All participating personnel are dismissed.

7. Conduct of Funerals when Military Personnel are Limited. When personnel are limited, military honors for funerals may be efficiently rendered by a detail of eight Marines and one bugler. The firing squad will stack-arms at the place from which volleys will be fired, which should be approximately 50 feet from the head of the grave. They then will return to the hearse and convey the body to the grave. After placing the casket over the grave, six members of the party will take position as the firing squad while the remaining two members remain at the grave and hold the flag over the casket during the service and rendition of military honors. The bugler should take position approximately 50 feet from the head of the grave until the volleys have been fired, at the conclusion of which the Marine shall sound "Taps." Then the two members holding the flag shall fold it. The flag will be handed either to the Marine in charge of the detail or to the military escort commander. The escort commander will present it to the next of kin in a dignified manner with a short statement such as "**On behalf of the President of the United States, the United States Marine Corps, and a grateful nation, please accept this flag as a symbol of our appreciation for your loved one's honorable and faithful service.**"

8. Unit Outdoor Memorial Services when Remains are Interned at Deceased Home of Record

a. There may be times when conducting a memorial service in a chapel is not possible or desirable. Such as in a combat situation, where no chapel is available, or when the commander desires to have an all hands, out-of-doors, memorial service. An out-of-door memorial service normally consists of: final roll call; boots and rifle ceremony; eulogy; and firing detail. This type of memorial service is for those Marines killed in the line of duty (e.g., killed in action (KIA), while a sentry on post, training accident.)

b. Normally this type of memorial service is conducted at company, or units of a similar size, level. The formation is company line, platoon line. (See figure 13-9.)

c. The personnel support required, in addition to the company, is:

(1) A "boots and rifle" detail consisting of three Marines for each KIA (one carries a rifle with fixed bayonet, one carries a helmet,

one carries a pair of boots and set of identification tags) are positioned six paces in front of and centered on the company commander. (See figure 13-9.) The rifle bearer is in the center, the helmet bearer is on the right and the boots/dog tag bearer is on the left.

(2) Firing detail positioned on the left front of the company, but facing so as not to fire over the formation. (See figure 13-9.)

(3) Bugler. Positioned on the right front of the company. (See figure 13-9.)

(4) Chaplain. (If available) Positioned near the company commander.

d. The recommended sequence of events is as follows:

(1) H-15 Minutes. Company is formed as described in enclosure 1, chapter 10, the "boots and rifle" detail(s), firing detail, bugler and chaplain are in position and at parade rest. (See figure 13-9.)

(2) H-Hour. The company commander calls the company to attention, then faces about so as the company is to his/her rear. The chaplain then announces "**LET US PRAY,**" and leads the company in prayer. (If no chaplain is available the company executive officer or company gunnery sergeant reads the "Marine's Prayer.") After the prayer is finished the company commander faces the company and commands "**FIRST SERGEANT.**"

(3) The first sergeant moves to a position three paces in front of the company commander and halts. The company commander then directs the first sergeant to "**READ THE FINAL ROLL CALL.**" The first sergeant faces the company and reads the roll of the Marines being honored (e.g., "**LANCE CORPORAL JOSEPH S. MARINE, 2D SQUAD, 3RD PLATOON, INDIA COMPANY, 7TH MARINE REGIMENT. KILLED IN ACTION 25 MARCH 1968 WHILE IN ACTION AGAINST AN ENEMY FORCE IN QUANG NAM PROVINCE, REPUBLIC OF VIETNAM**"). (Similar information is read for each KIA.)

(4) As each Marine's name is read, the three Marines representing him execute the following movements:

(a) The rifle bearer takes one step forward, halts, rotates the rifle counter clockwise until the bayonet is facing down and the magazine well is towards the company, sticks the bayonet into the ground, then steps back.

(b) The helmet bearer then steps forward, places the helmet on the butt of the rifle and steps back.

(c) The boots/dog tag bearer then steps forward, hangs the dog tags from the pistol grip, places the boots in front of the rifle (toes towards company) and steps back. This process is repeated as each KIA's name is read.

(5) After the last KIA's name is read, the first sergeant returns to his/her post behind the company. The company commander then commands "**Parade, REST.**" The company commander then talks about each Marine, where they were from, how long they were with the company, etc. After each Marine has had a "eulogy," the company commander then commands "**Company, ATTENTION**" and "**Present, ARMS.**" The company and "boots and rifle" detail(s) execute.

The company commander then faces about and commands "HONOR THE DEAD." The company commander and guide then present arms.

(6) The noncommissioned officer in charge of the firing detail has the detail fire three volleys, and go to present arms as described in enclosure 2, chapter 14. The bugler then plays "Taps." After the last note of "Taps" the company commander and guide go to the order. The company commander then faces about and commands "Order, ARMS." All hands go to order arms.

(7) The company commander or first sergeant, as described in enclosure 1, chapter 10 then dismisses the company.

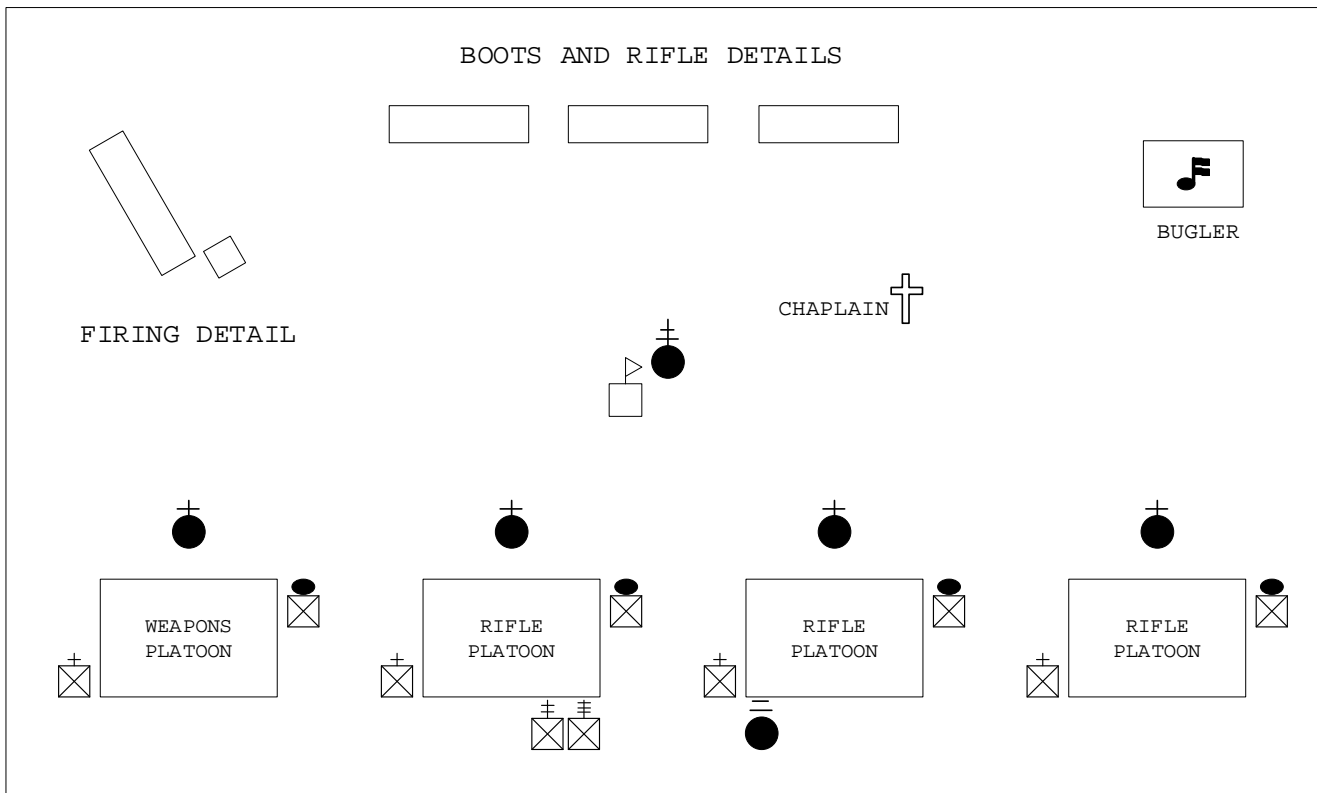

Figure 13-9.--Company Memorial Formation.

9. Unit Indoor Memorial Services when Remains are Interned at Deceased Home of Record

a. When conducting memorial services in a chapel, the key thing to remember is that the chaplain has the final authority. Close coordination with the chaplain and the family (if present) is required. Although each religion has variations in their services, the basic memorial service would follow a sequence of events something like the following:

- (1) Prelude. Musical selections.
- (2) Welcome. Usually by the chaplain or commander.

(3) Posting of the colors and "*National Anthem.*" (See enclosure 1, chapter 7, section 3, paragraph 8.) The color guard is uncovered and unarmed and the riflemen may be omitted.

(4) Invocation (posting of colors and invocation may be reversed).

(5) Bible readings, hymns, eulogies, etc. (Navy Hymn, Marine's Prayer, etc.).

(6) Call the Roll; after the eulogy, the unit commander will stand and command "**CALL THE ROLL.**" The first sergeant (or platoon sergeant, etc.) will stand and begin calling the roll of members of the deceased's unit who are in attendance. They will answer "**Present.**" This will be done three times. The fourth name to be called will be the deceased. The first sergeant will repeat the name three times, each time increasing the volume. After the third time, the bugler will play "*Taps.*"

Note: If the deceased's family desires not to have "Call the Roll" then this will be omitted and only "*Taps*" played.

(7) "*Taps.*"

(8) Benediction and retiring of the colors (may be in any order).

b. If a firing detail is used during an indoor memorial service, the detail fires three volleys just before "*Taps.*" The detail is outside the chapel, and fires in a direction away from the chapel.

Chapter 14

Loading and Ceremonial Firing of the Service Rifle

TABLE OF CONTENTS

<u>IDENTIFICATION</u>	<u>TITLE</u>	<u>PAGE</u>
1.	General.....	14-2
2.	To Load.....	14-2
3.	To Fire by Volley.....	14-5
4.	To Unload.....	14-6
Figure 14-1	Firing Party Formed for Ceremonial Firing.....	14-2
Figure 14-2	Riflemen Face Half Right.....	14-3
Figure 14-3	Riflemen Moves the Left Foot 12 Inches to the Left	14-3
Figure 14-4	Rifle to Port Arms.....	14-4
Figure 14-5	Chambering a Round.....	14-4
Figure 14-6	Firing Party in Position of Aim and Fire.....	14-5

Chapter 14

Loading and Ceremonial Firing of the Service Rifle

1. General

a. For ceremonial firing of the rifle, only the front rank of units larger than a squad executes the loading and firing of the rifle.

b. Normally, a firing detail will consist on one noncommissioned officer and seven riflemen. When inadequate manpower is available to provide a full firing detail then one noncommissioned officer and at least three riflemen should be provided. The firing detail should be composed of an odd number of riflemen to honor ancient naval superstitions and traditions.

c. Except during actual firing, loaded rifles are kept on SAFE without command until **"UNLOAD"** or **"Inspection, ARMS"** is ordered.

d. In order to enhance the appearance of the firing party, magazines with three rounds will be inserted into the rifle out of view of spectators. Two expended cartridges should be placed in the magazine below the three blank cartridges so that adequate tension will be placed on the magazine spring. A round will not be placed in the chamber until the command **"LOAD"** is given.

2. To Load

a. The firing party is formed in line, with the noncommissioned officer in charge three paces in front of and one pace to the right of the firing party.

b. With the firing party formed and at attention (see figure 14-1), the command is **"With Blank Ammunition, LOAD."** The movements are executed quickly and smartly.



Figure 14-1.--Firing Party Formed for Ceremonial Firing.

c. On the command "**LOAD,**" members of the firing party execute the following sequence of movements:

- (1) Face half right. (See figure 14-2.)



Figure 14-2.--Riflemen Face Half Right.

(2) Move the left foot 12 inches to the left. (See figure 14-3.)
The legs are kept straight so the weight of the body rests equally on both feet.



Figure 14-3.--Riflemen Moves the Left Foot 12 Inches to the Left.

(3) Raise the rifle to port arms. (See figure 14-4.)



Figure 14-4.--Rifle to Port Arms.

(4) Pull the charging handle fully to the rear with the right hand and release it, thus chambering a round of blank ammunition. (See figure 14-5.)



Figure 14-5.--Chambering a Round.

(5) Move the right hand to the pistol grip.

3. To Fire by Volley

a. After the rifles are loaded as described in paragraph 2 of this chapter, the noncommissioned officer in charge of the firing party orders, **"Ready, Aim, FIRE."**

b. On **"Ready,"** each rifleman moves the selector lever from SAFE to SEMI-AUTOMATIC with the right thumb.

c. On **"Aim,"** each rifleman raises the rifle to a position of 45 degrees from the horizontal, places the butt of the rifle firmly in the right shoulder, and rests the handguard in the "V" formed by the thumb and forefinger of the left hand. The fingers are extended and joined. The left wrist is straight. The right hand is wrapped around the pistol grip from the right. The right elbow is raised to near shoulder height. The head is turned 90 degrees to the left and held erect. Both eyes remain open with the right eye looking out over the front sight. (See figure 14-6.)



Figure 14-6.--Firing Party in Position of Aim and Fire.

d. On **"FIRE,"** squeeze the trigger quickly and lower the rifle to the position of port arms.

e. To continue firing with weapons equipped with blank firing adapters, the commands are **"Aim, FIRE."** Each command is executed as explained above.

f. To continue firing with weapons not equipped with blank firing adapters, the commands are **"Ready, Aim, FIRE."**

(1) On **"Ready,"** each rifleman manually chambers the next round.

(2) "**Aim**" and "**FIRE**" are executed as describe above.

g. After the last round has been fired, rifles are brought to the position of port arms. From this position, the noncommissioned officer in charge of the firing party gives the command of "**Present, ARMS.**" This movement is executed in three steps on the command of execution "**ARMS.**"

(1) With the left foot extended, pivot on the heel of the left foot and toe of the right foot, as in the first count of a left face.

(2) Bring the heel of the right foot smartly against the heel of the left foot, completing the left face.

(3) The riflemen then moves the rifle to present arms. The noncommissioned officer in charge of the firing party then executes a right face and present sword.

h. After the ceremony, (memorial service, funeral, etc.) the firing party is brought to order arms, faced to the right and marched from the site of the ceremony.

4. To Unload

a. The weapons will be unloaded and inspected as soon as possible after leaving the site of the ceremony and out of sight of the spectators, if possible.

b. The command is "**UNLOAD.**" It is executed by executing inspection arms with magazine as describe in enclosure 1, chapter 3, section 1, paragraphs 14.a. and 14.b.